

SECTION EIGHT: On-Line Description SignaSetter

Important

Your On-Line Processor has a built in exhaust blower. Even if the main switch is switched off, the blower will still be on. This is to prevent chemical fumes in the conveyor/imagesetter. If a timer is connected in series with the main power cable, the machine has to be modified, so that the exhaust blower is always running.

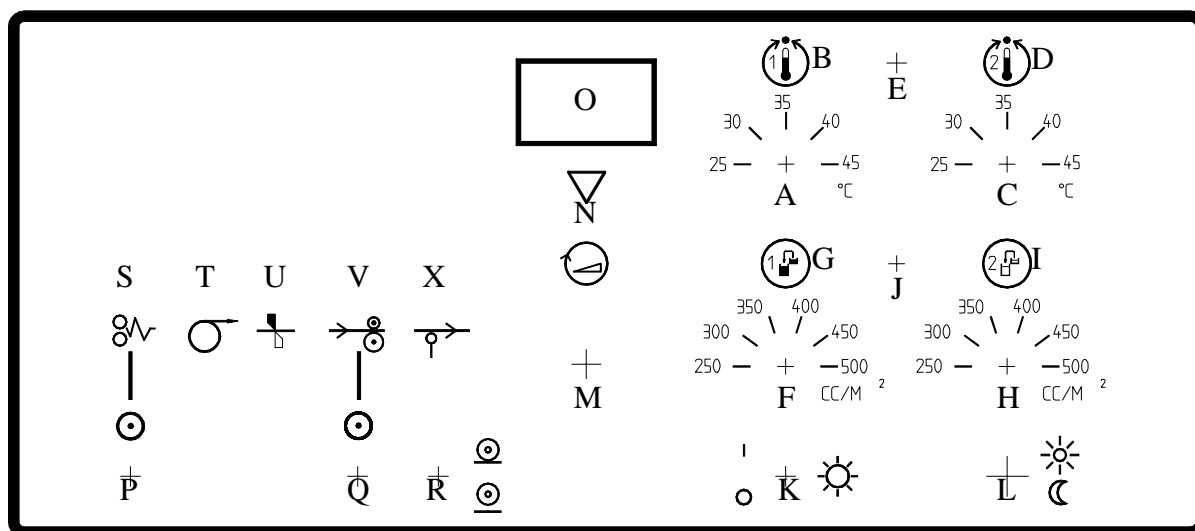

A	Temperature Adjustment Developer	M	Developing Seconds Adjustment
B	Heat ON Indicating Developer	N	NO FEED Signal (Indicates when inserted film is free of inlet) Only used in OFF-LINE position !
C	Temperature Adjustment Fixer	O	Display, shows development seconds and temperature
D	Heat ON Indicator Fixer	P	Error Signal Reset Switch (NOT USED)
E	Temperature Readout DEV/FIX	Q	Switch for Set Load Signal.
F	Volume On Developer Replenishment (Max. programme approx. 40cc).	R	Switch for Off-Line/On-Line
G	Developer replenish indication	S	Error Signal (Lamp and intern Buzzer) (Flashing and buzzing when the film counter is on 0. Only flashing, when the level in the tank is too low; and only buzzing when there is no exhaust). NOT USED.
H	Volume On Fixer Replenishment (Max. programme approx. 40cc).	T	Load Signal
I	Fixer replenish indication	U	Cut Signal
J	Manual replenish switch	V	Busy Signal
K	Display light ON/OFF	X	Ready Signal
L	Switch for Stand-By/Operate Select. When Stand-By is selected, Error (L) lights continuously.		

SECTION EIGHT: On-Line Description SignaSetter

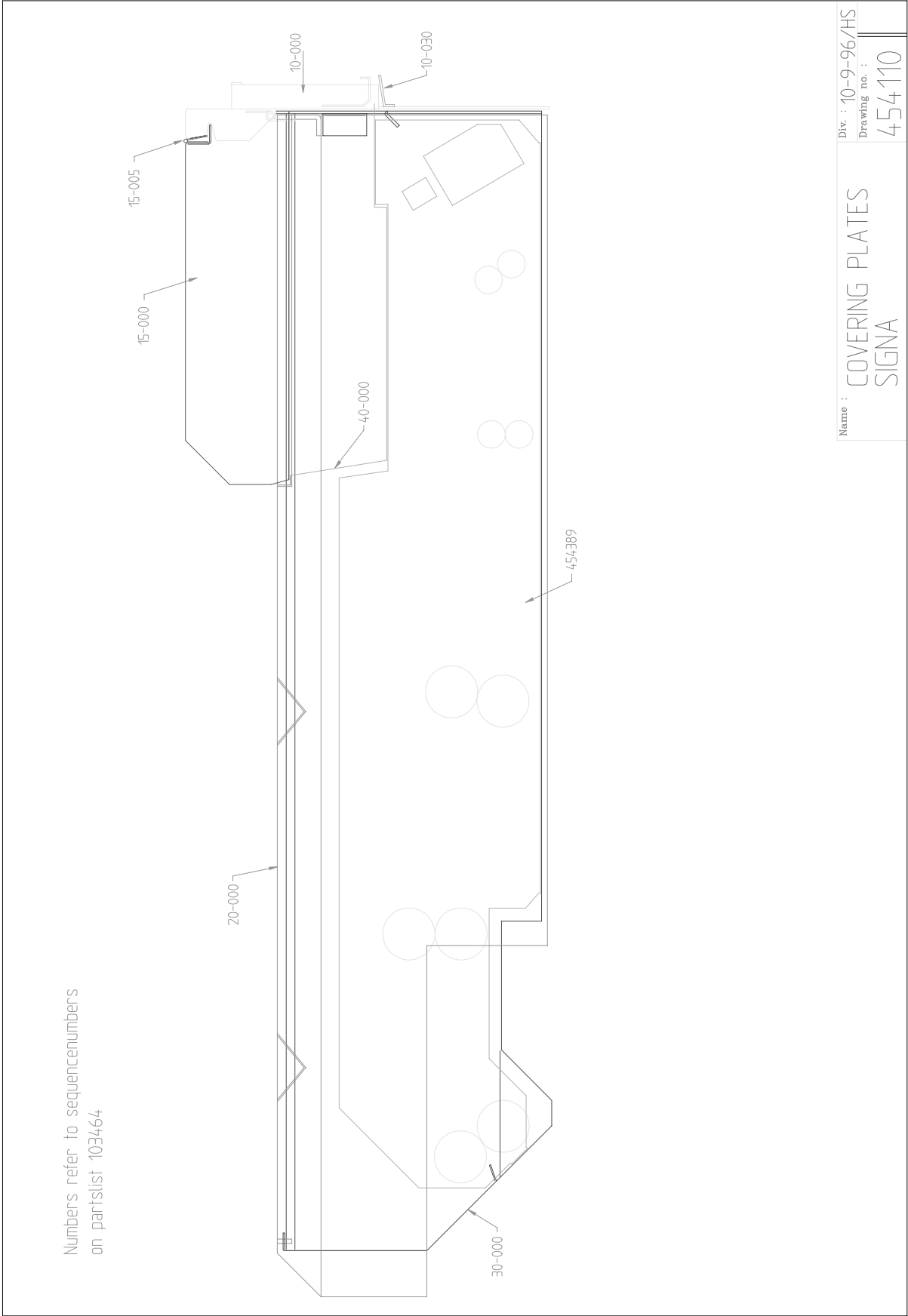

Name : COVERING PLATES
SIGNA

Div. : 10-9-96/HS
Drawing no. : 454110

SECTION EIGHT: On-Line Description SignaSetter

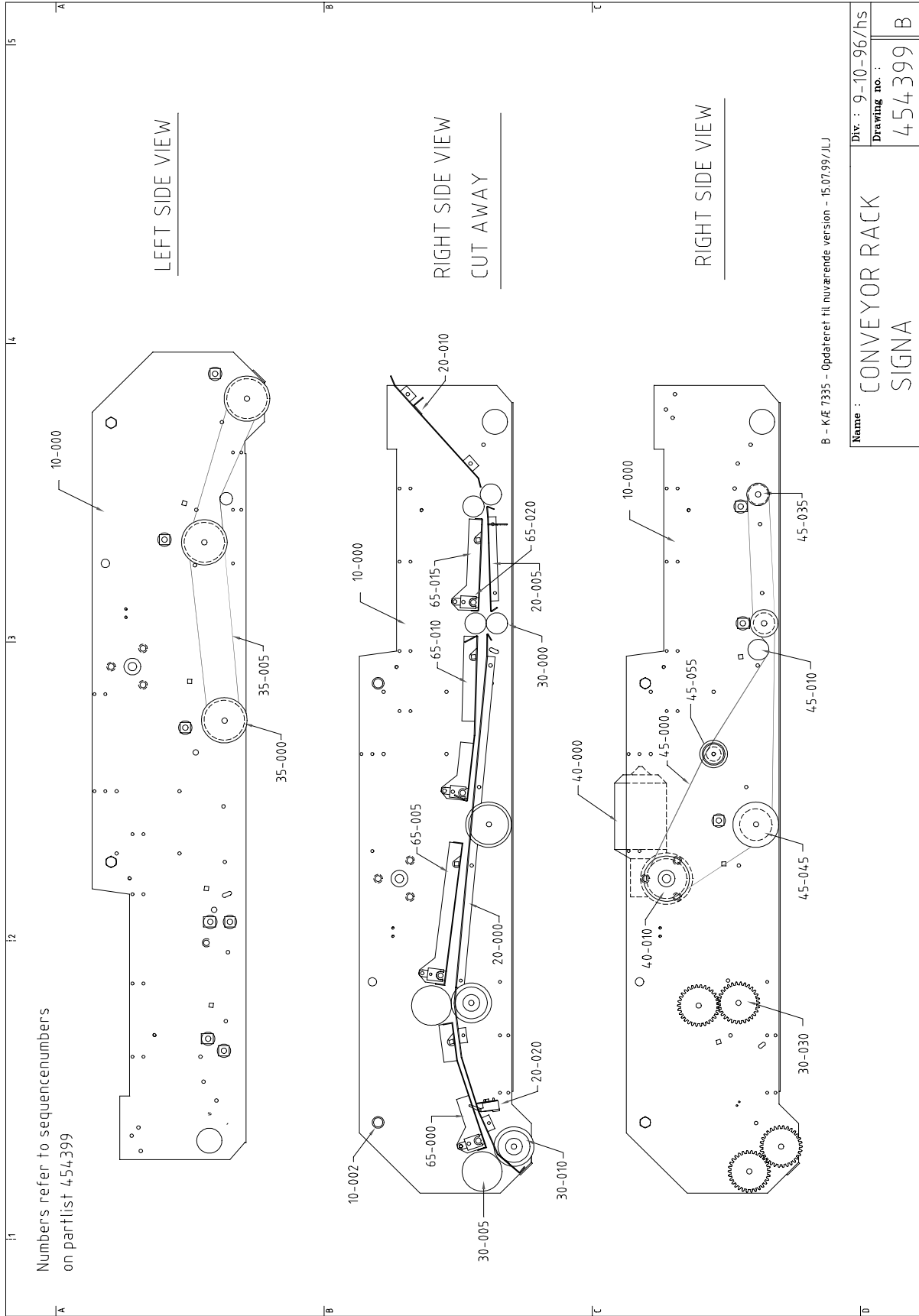

SECTION EIGHT: On-Line Description SignaSetter

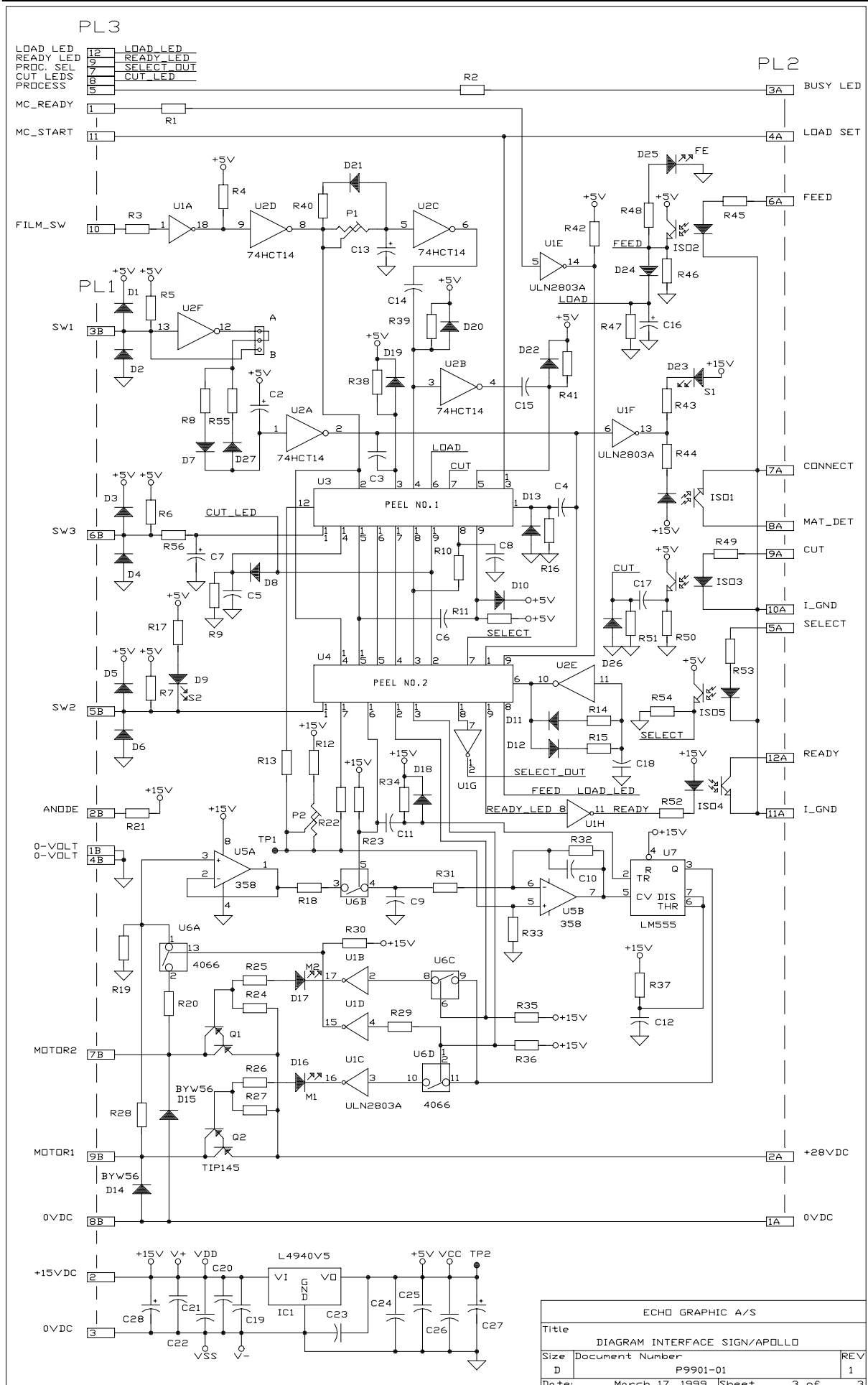

ECHO GRAPHIC A/S		
Title		
DIAGRAM INTERFACE SIGN/APOLLO		
Size	Document Number	REV
D	P9901-01	1
Date:	March 17, 1999	Sheet 3 of 3

Interface PCB Diagram
GL541 Manual, English SignaSetter

SECTION EIGHT: On-Line Description SignaSetter

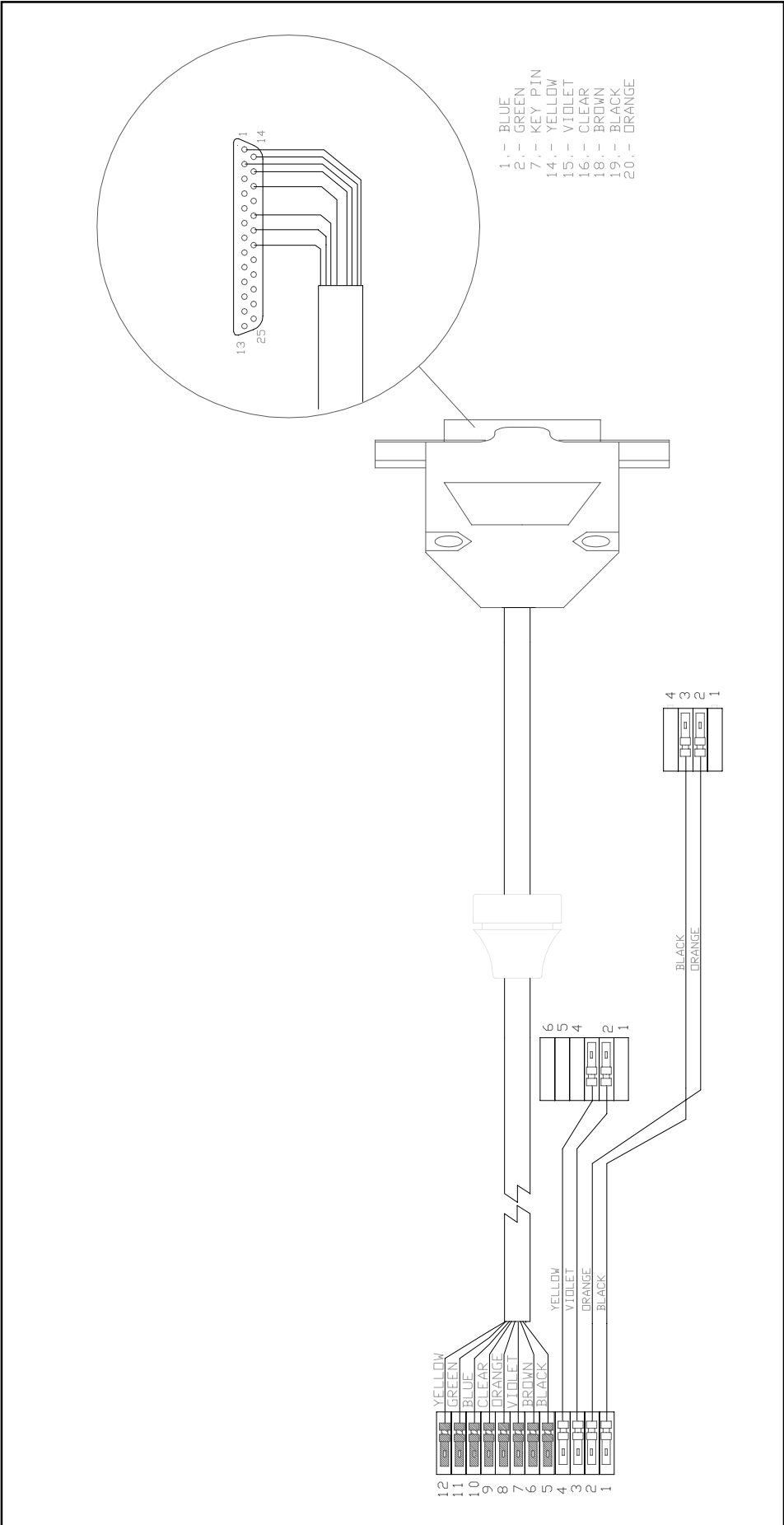

Cable Processor <-> Imagesetter

SECTION EIGHT: On-Line Description SignaSetter

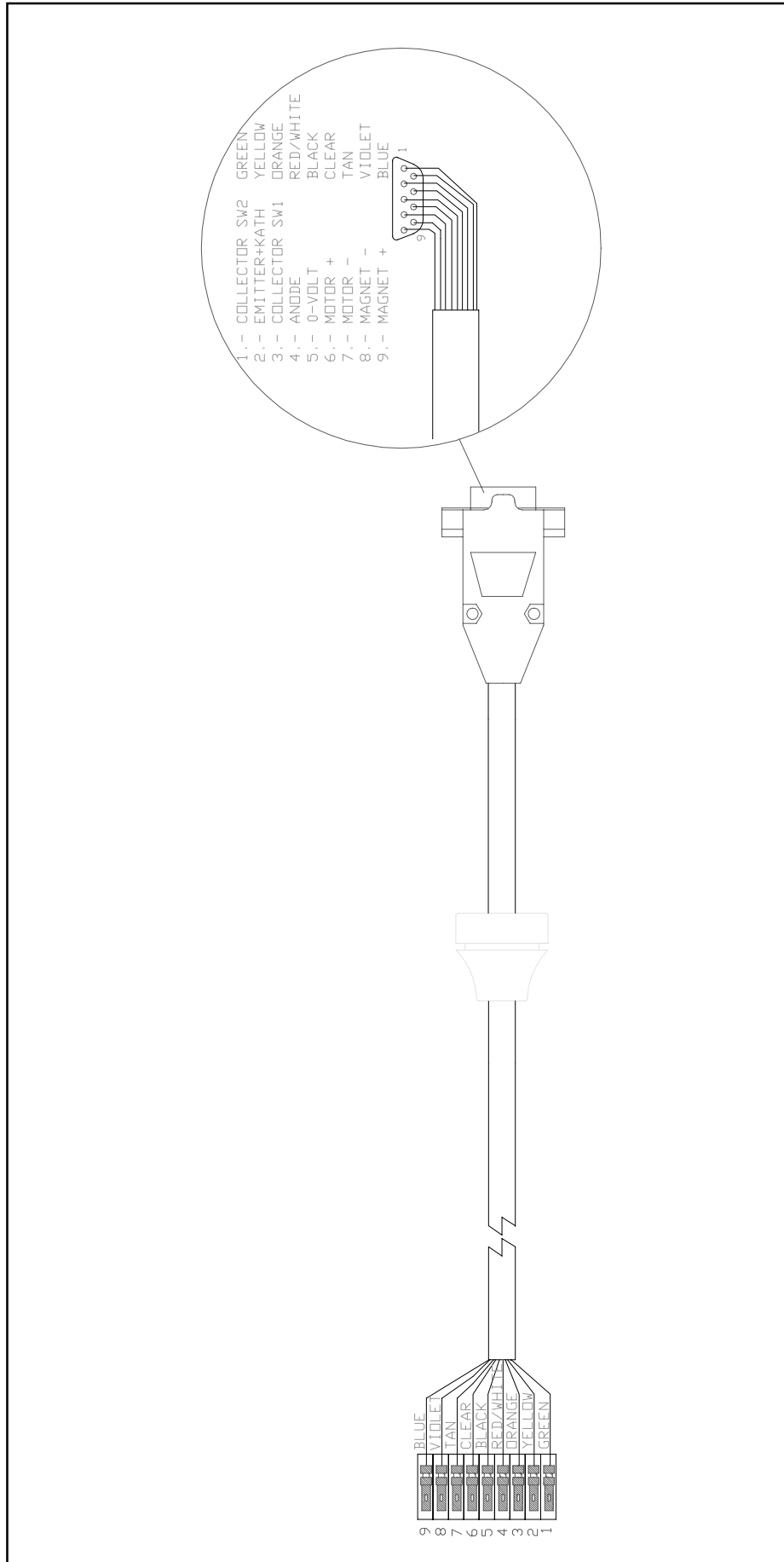

Cable Processor <-> Conveyor

SECTION EIGHT: On-Line Description SignaSetter

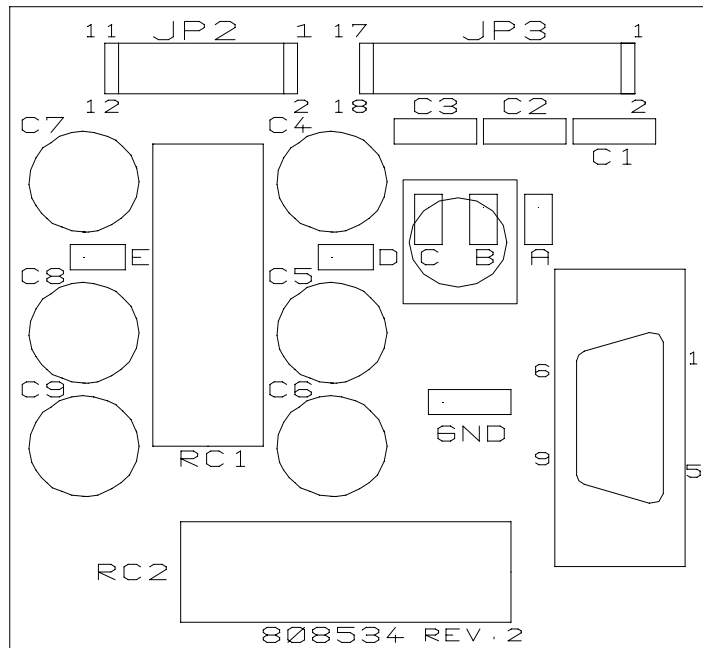

P9806

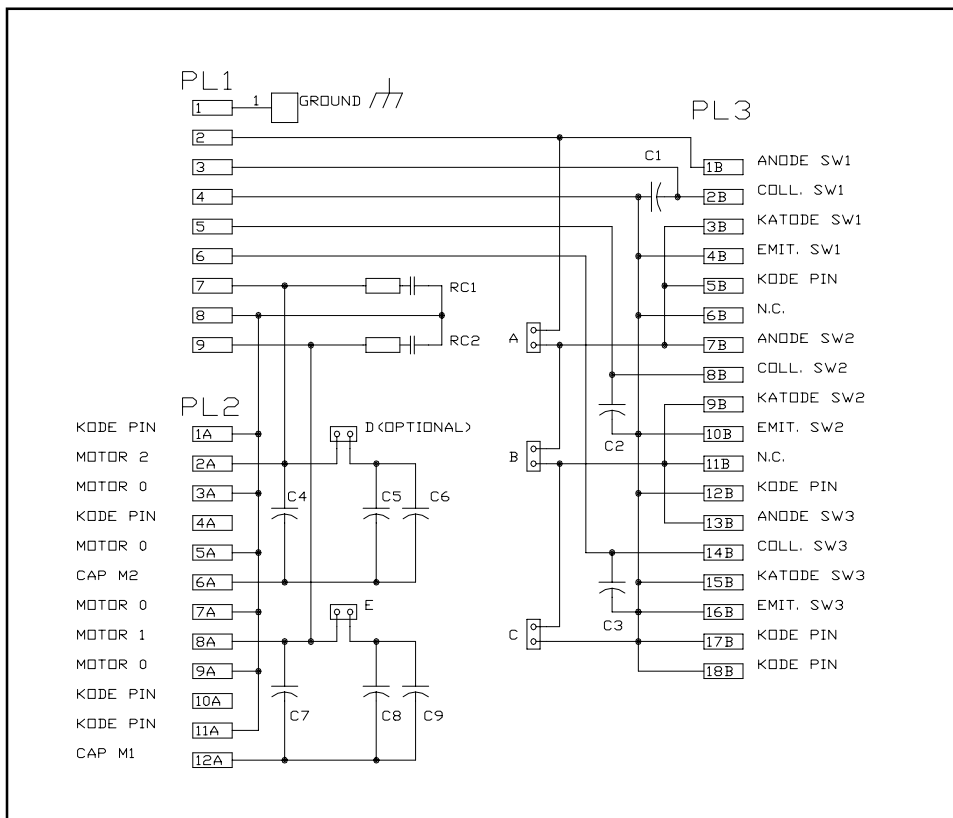

P9805-01

SECTION EIGHT: On-Line Description SignaSetter

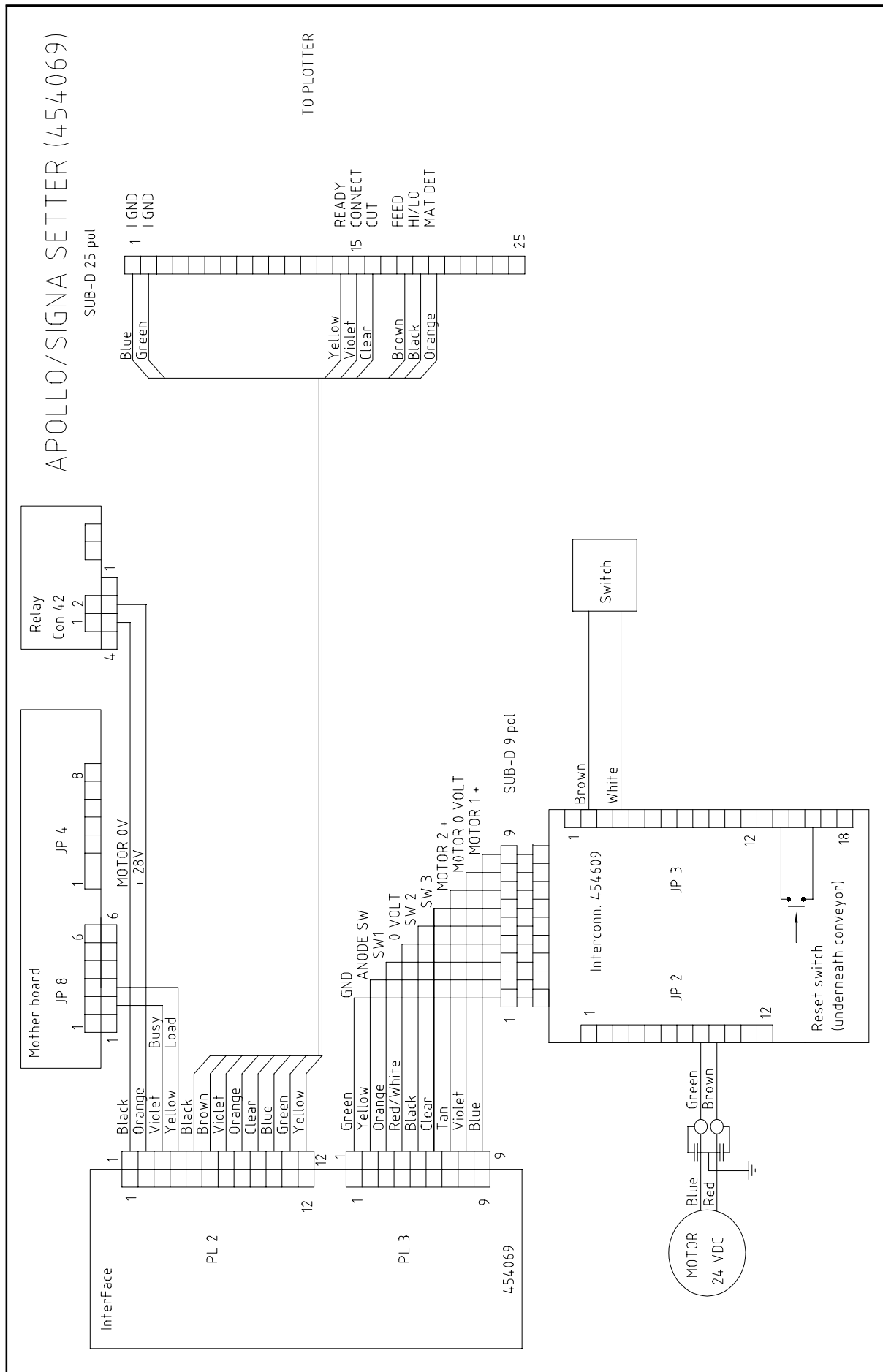

454134

Connections between processor - conveyor - imagesetter

SECTION EIGHT: On-Line Description SignaSetter

