

Contents

Section	Page
1.1 Topics Covered.....	3
1.2 Processor Description	3
2.1 Processor Operation	9
2.2 Electrical and Mechanical Hazards.....	9
2.3 Fire Prevention	9
2.4 Chemical Hazards and Handling	9
2.5 Chemical Disposal	10
2.6 Exhaust, Temperature and Humidity	10
2.7 Important safety information	11
3.1 Pre-Installation Environmental	17
3.2 Electrical Pre-Installation.....	18
3.3 When the Shipment Arrives	19
3.4 Pre-Installation Verification	19
3.5 Set-Up and Operational Verification	19
3.6 Operational Check:	26
3.7 Chemistry Installation:.....	27
4.1 General.....	29
4.2 Night/Stand-by/Process.....	29
4.3 Temperature/Speed/Replenishment	30
4.4 Replenishment Settings	30
4.5 Daily Operation.....	31
4.6 General Operation:.....	31
4.7 Processing	31
4.8 Changing Exhausted Chemistry.....	32
4.9 Panel Operations	33
4.10 Shifting between Modes	33
4.11 Setting up the computer - Region	34
4.12 Setting up the Computer - Changing Programme Entry Number.....	34
4.13 Setting up the Computer - Temperature, Replenishment and AOX	35
4.14 Setting up the Computer - Timer Setup	37
4.15 Setting up the Computer - General	38
4.16 Setting up the computer - Day Operation	39
4.17 Error Messages.....	39
4.18 Daily Maintenance Messages	40
4.19 Setting up the Dryer temperature.....	40
5.1 Introduction.....	41
5.2 Preventive Maintenance	41
5.3 Troubleshooting	45
5.4 Electrical Troubleshooting	49
5.5 Printed Circuit Measurements.....	50
5.6 Repair instructions	51

SECTION 1

SECTION 2

SECTION 3

SECTION 4

SECTION 5

SECTION 6

SECTION 7

SECTION 8

SECTION 9



SECTION ONE: General Information

5.7 Accessing the configuration Utility.....	51
5.8 Service menu structure.....	52
5.10 Testing of sensor inputs.....	52
5.9 Relay test.....	53
5.11 Technical information setup.....	54
5.12 Mechanical machine setup.....	54
5.13 Sensor configuration setup.....	55
5.14 Calibration menu.....	55
5.15 Updating the software in the Celis Control.....	57
5.16 Updating the Software in the Celis Control.....	58
6.1 General.....	59
6.2 Removal/Replacement Procedures	59
6.3 Sensors in EG models	71
6.4 Complete Roller Overview	72
6.5 Axle Overview	72
6.6 Complete Gearwheel View	73
7.1 Drawings, Electrical.....	75
Interconnection diagram for one section processors, drawing 6336a.....	75
Interconnection diagram for two section processors, drawing 6324a.....	76
Interconnection diagram, drawing 6324 and 6336	77
Relay Board Drawing 4080101a.....	78
Relay Board Drawing 4080101b	79
Relay Board Location Drawing 4080101	80
Main Board Communication Drawing 40800a.....	81
Level sensor input Drawing 40800b	81
Main Board Power supply Drawing 40800c.....	82
Main Board Conveyor motor Drawing 40800d	82
Main Board Conveyor sensor Drawing 40800e.....	83
Main Board Temperature Drawing 40800g	84
Main Board IR-sensors. Drawing 40800h	84
Main Board Mechanical & US-sensors. Drawing 40800i	84
Main Board Location Drawing 4080100	85
Display Communication Drawing 4080103a.....	86
Cable between Mainbox and Panel Part nr. 890685	86
Display Location Drawing 4080103	87
8. Optional On-Line Description.....	89
Rack drawings, Specifications...	
9. Parts List	

© 2002 Echo Graphic A/S

This manual is intended for information use only. Specifications can be subject to change without any prior notice and we do not assume any responsibility for possible errors or omissions in the text.

1.1 Topics Covered

This manual provides installation, operation, maintenance, and replacement parts information for the series of EG, EP and EGP processors prepared for on-line operation. Figure 1-A shows a typical processor (EG 901).

Special versions of EG, EP and EGP processors for on-line processing from exposure units (scanners, etc.), are covered in special manuals or sections.

1.2 Processor Description

General: The EG and EP processors are high volume, easy to use, three-bath, replenishment processors. The EGP processors are also high volume, easy to use, replenishment processors but equipped with six baths. The EG processors are ideal for Rapid Access processes, Contact and Line work as well as for photo-typesetting. Among the range of possible film types and applications, we can mention contact work, camera work, scanner work, laser or conventional, photo-typesetting and camera projections.

Standard Accessories: Replenishment containers for dev. and fix., customer spare parts kit (assortment of gears, bearings, etc.). Features include; chemical replenishment (automatic and manual) with recirculation, variable speed control, separate developer and fixer temperature controls, automatic monitoring of chemical levels, automatic antioxidation programme (AOX), built-in exhaust blower, standard plumbing and a built-in dryer that delivers completely dry output.

Optional Accessories: For two-room installation in a darkroom wall a set of darkroom panels can be supplied on order. For use with two-room installations also a top feed from outside the darkroom into the developer rack and a rewash feed into the wash rack can be supplied (29" and wider).

If the daylight inlet to the developer rack is to be used intensively. An optional photocell



Fig. 1-A

for this inlet will start and stop and replenish automatically.

A standard daylight lid accepts various sized cassettes and allows processing in normal room lighting (using a take-up cassette), thus eliminating the need for a darkroom.

Chemical Solutions: The processor will process a wide range of Rapid Access and RALI (Rapid Access Lith) chemicals such as Kodak Ultratec, Agfastar, Typon Typotec, Fuji Grandex, etc. Always check with the supplier of developer, fixer, film and polyester that the materials used are compatible.

Replenishment and Recirculation: Two individual replenishment pumps add fresh chemistry (either automatically or manually) to the exhausted chemistry. As the replenishment takes place the excess exhausted chemistry drains into holding containers. The replenishment chemistry is drawn up by replenishment pumps and recirculated by the recirculating pumps, when the relays of the two individual replenishment pumps are activated, ensuring thorough mixing. This produces a consistent density throughout the

SECTION ONE: General Information

Material Path: The EG series of processors feature four sizes of input width: 75 cm (29"), 91 cm (36"), 114 cm (45") 135 cm (54"). The EP and EGP processors feature three sizes of input width: 75 cm (29"), 91 cm (36") and 114 cm (45"). The processors come in four different tank sizes/path lengths: 20 cm for polyester operation, 32 cm for normal film capacity, 44 cm for medium film capacity or 67 cm for high capacity film processing. The transport system of the EG, EP and EGP processors has proven to give a very safe transport.

 **Night Mode:** The night mode heats up the chemistry in the processor's first two stations and maintains it at an operator-set temperature. This mode also ensures that the chemistry does not oxidize or drop to a low level, circulates all chemical fumes and de-activates the transport system. This mode will automatically turn the heaters, recirculating pumps and replenishment pumps on and off as needed. The built-in exhaust blower will always be ON. The night mode extends the life of the chemistry, reduces wear on the system's components, and saves energy. (The daylight lid should always be left open in night mode).



Stand-by Mode: The stand-by mode operates exactly as the night mode. The only difference is that the dryer's upper heaters are on and the processor's transport system can be activated by the presence of film or polyester plate. This mode also extends the life of the chemistry, reduces wear on the system's components and saves energy. The daylight lid should always be left open in stand-by mode.



Process Mode: The process mode will only operate with the presence of film or polyester plate. When either film or polyester plate is inserted into the processor a sensor

is activated and the recirculating pumps, plumbing valve, transport rollers and both dryer heaters with fans all turn on. The processor will remain in this mode until the material exits the dryer at which time the processor will automatically return to the stand-by mode.

Solution Temperatures: The first two stations are separately maintained at the operator-set temperature by two efficient heaters in line with the recirculation pumps. The heaters are monitored and controlled by two temperature sensors, which turn the heaters on and off as required. The temperatures of each station can be displayed at any given time by the toggling of the temperature display switch.

Roller Drive/Transport Speed: The three roller assemblies and dryer rollers are driven by an operator-controlled variable speed DC motor, drive shaft, gears and a series of sprockets. The transport system will only function in the operating mode. NOTE: The transport system will not operate if a low level of chemistry is present or if the processor is in night mode.

Pumps: The processors is equipped with three pumps. The pumps circulate the developer (activator) and fixer (stabilizator) chemistry with its own tank (bath). Their pumping rate is preset at the factory and requires no operator adjustments. The circulation of the water (in the wash station) is controlled by the water valve.



AOX: The anti-oxidation programme (AOX) automatically replenishes the chemistry as ml/h or % per 24h. This not only keeps fresh chemistry in the tanks but also helps eliminate a low tank level condition. With every AOX signal the drive runs for a few seconds to prevent that the rollers sticks together.

INTERNAL CONTROLS: The internal controls are described in paragraphs a. through

a. Power ON/OFF Switch - The power ON/OFF switch controls the main power to the processor. Any time the power switch is turned OFF for an extended time the top cover should be lifted so that chemical moisture does not accumulate. The power switch should always be turned OFF and the top cover lifted at the end of each work day. The power switch is located at the rear of the processor.

A - main switch

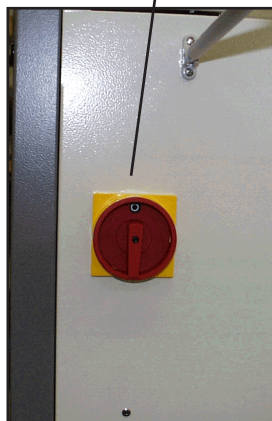

Fig. 1-B



Fig. 1-C

b - main fuse

b Main Fuse - This 16 amp. 230 volts fuse protects the processor from a possible power surge or a short circuit. The main fuse is accessible from the left side of the processor when the side cover is removed.

c. Gear Train - This series of sprockets are driven by the drive motor. When the system requires the rollers to be turning, the gear train transmits turning power from the drive motor to the roller racks through a series of sprockets and gears. Fig. 1-D.



Fig. 1-D

c - gear train situated behind this plate

d. Drive Motor - The drive motor speed is controlled by the electronics. The drive motor turns the rollers to transport the film or polyser plate through the processor.

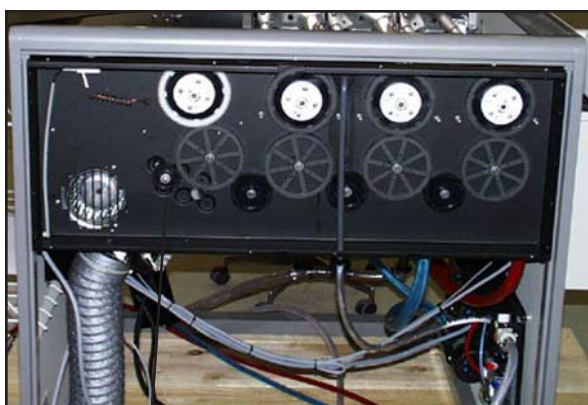

Fig. 1-E

d - drive motor

Fig. 1-F

d - drive motor

SECTION ONE: General Information

e. Recirculating Feed - Recirculated chemistry enters the tank here from the recirculating pump.

f. Water Feed - Fresh water enters the tank here, whenever processing takes place, or in a low level situation. Fig 1-E.

g. Temperature Probe - This probe (submerged in the chemistry) senses and controls the temperature of the chemistry through the interface box and temperature PCB. When the temperature reaches its setting the probe sends a signal to shut down the heater. The probe also has the ability to display the current chemical temperature. The wash station does not require a temperature probe. Fig. 1-E.

h. Overflow Pipe - As replenishment occurs the exhausted chemistry is drained through the overflow pipe, thus keeping the chemistry at a prescribed level. The chemical levels are adjustable by the adjustable overflow piece on top of the overflow. Fig. 1-F.

i. Low Level Sensors - If the chemistry level falls below these three sensors, the heat and the transport drive will not operate. Also, a number indicating which tank is low



Fig. 1-G

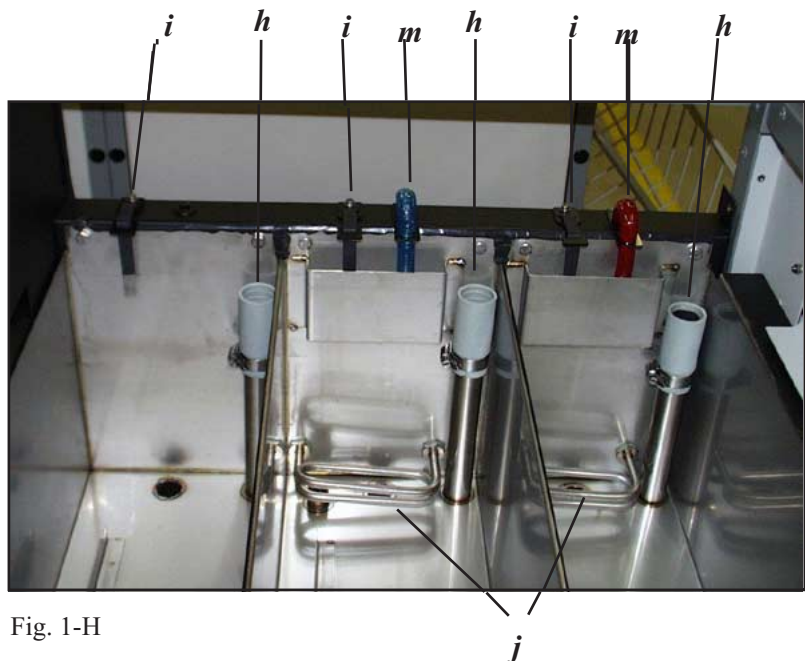

Fig. 1-H



Fig. 1-I

j. Heating Element - Heats the chemistry to the operator-set temperature. The wash station does not require a heating element. A safety thermostat will act directly on the heating element in case of failure in other systems.

Fig. 1-F.

k. Media Feed Sensors - When material is fed into the processor the sensors turn on the no-feed light (only in off-line position), circulating pumps, transport system, dryer and auto replenishment. Fig. 1-G.

l. EG Blower - There are two blowers, one below and one above the dryer rack, which blow hot air on the dryer rack rollers and on the film/polyester plate.

m. Replenishment Feed - When replenishment takes place fresh chemistry enters the tanks here.

1.3 To Order Accessories and Supplies
Contact your dealer for accessories, supplies, technical service and spare parts.

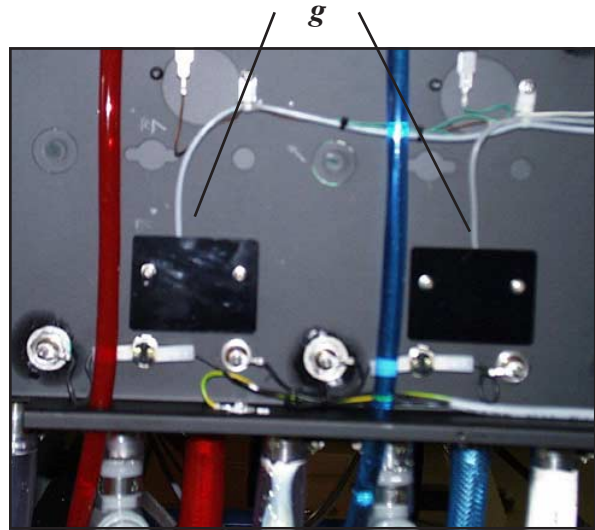

Fig. 1-J

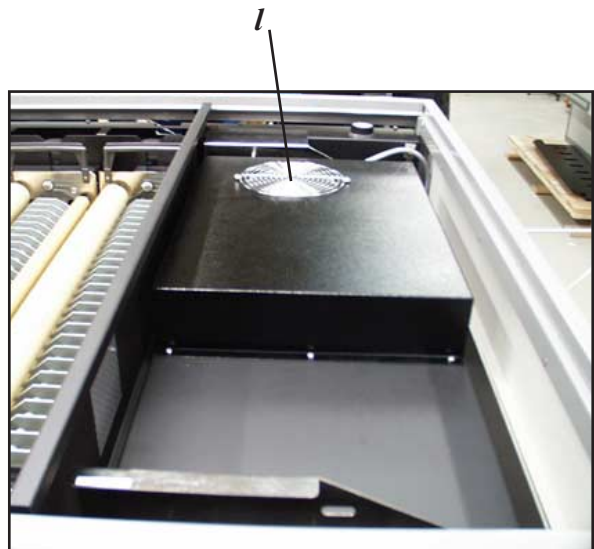

Fig. 1-K

SECTION ONE: General Information

2.1 Processor Operation

Never allow loose clothing or jewelry to come close to the gear train, media transport area, an electrical connection or any terminal block. Service work that must be performed while the processor is operating or that necessitates removing the processor's panels should be performed only by qualified service technicians. The main power to the processor must be turned off and the main switch locked by a padlock before panels are removed by anyone but trained service personnel.



When the processor is in stand-by mode it will periodically start up, run and then shut down. The processor must be turned off before servicing drive motor, gear train dryer compartment and electrical components.

2.2 Electrical and Mechanical Hazards

Follow safety precautions to minimize the risk of electrical shock, burns and equipment damage when operating any equipment. Photographic processing machines are mechanically and electrically complex and contain volumes of chemicals for which reason extreme caution is required.

Periodical check of all wiring for loose connections and worn or frayed insulation. To prevent accidents, check mechanical parts for loose hardware and broken parts.

The risk of receiving electrical shock is reduced by removing all jewelry while servicing the equipment. Turn off and lock the main switch by a padlock before making repairs. Make sure the processor has good electrical grounding.

2.3 Fire Prevention

The area around the processor must be kept clean. Keep dust, wood shavings, paper cuttings and waste materials out of the dryer compartment. Do not remove dryer blower channel from an operating processor.

Fire extinguishers must be available in the room where the processor is operating and where paper and chemicals are stored.

2.4 Chemical Hazards and Handling

Misuse of almost any chemical may create a hazard of some type. Generally, photochemicals are no more hazardous than many common cleaning products, however, there is still a risk of danger. When handling and storing chemicals follow the precautions and procedures below.

- a. Never sniff a container or open bottle to determine its contents. A cautious sniff of the cap or lid is safer.
- b. When needed, wear protective clothing and equipment. Wear safety goggles when servicing equipment and rubber gloves when handling chemicals.
- c. Label storage containers properly. Avoid storing hazardous chemical on high shelves or in unprotected glass containers. Keep chemicals away from children. Do not store chemicals in a refrigerator used for food because they may contaminate food or be mistaken for edibles.
- d. Ensure proper ventilation in the area where chemicals are being used or stored.
- e. Observe the manufacturer's recommendations for using and mixing chemicals.



Overexposure to photographic chemistry may cause skin irritation to certain individuals.

PHOTOGRAPHIC CHEMISTRY EMERGENCY AND FIRST AID PROCEDURES:

- SKIN - Flush thoroughly with water.
- EYES - Flush thoroughly with water and consult a physician.
- INGESTION - Consult a physician immediately.

2.5 Chemical Disposal

Photographic processing wastes normally contain diluted chemicals. These chemicals should be collected and disposed of in accordance with local environmental codes. Dumping chemicals into a drain system could lead to a pollution problem. Contact local water treatment and sewer district authorities before disposing of chemical solutions.

2.6 Exhaust, Temperature and Humidity

It is important to establish correct exhaust to obtain trouble free processing. Make sure that the exhaust hose from the built-in exhaust blower in the processor is properly connected to the stud at the rear end below the receiving basket, fig. 2-A. The built-in exhaust removes chemical fumes from processor and installation site. Chemical fumes are corrosive and if the processor is switched 100 % off at night, the wet section should be drained for chemistry.

Room temperatures between 18-26°C (65-80°F) with a relative humidity between 35% and 75% are ideal for photographic processing and comfortable working conditions.



Fig. 2-A

2.7 Important safety information



IMPORTANT SAFETY INFORMATION

READ BEFORE OPERATING AN EG PROCESSOR

The processor is a complex machine with moving parts such as the gear train and media transfer components. It uses photoprocessing chemicals which are irritating to eyes, lungs and skin. High voltage is used to power the processor. The dryer compartment produces heat.

- **High voltage may cause electric shocks, burns or even death.**
- **Hands or fingers may be pinched or injured by moving parts or while handling heavy parts.**
- **Dryer compartment heat may ignite combustible materials and cause fires.**
- **Eyes, skin and lungs may be irritated by photochemicals. Before using photoprocessing chemicals always read the Material Safety Data Sheets (MSDSs) for information about the hazards of the particular chemicals and how to use them safely.**



This alert symbol indicates specific safety hazards and ways to avoid accidents. Ignoring safety information may lead to serious injury or property damage.



ELECTRICAL HAZARD

HAZARDOUS VOLTAGE CAN CAUSE ELECTRIC SHOCK, BURNS
OR EVEN DEATH

- Processor must be permanently and continuously grounded according to standards in the National Electrical Code and manufacturer requirements.
- If the processor is hardwired to the building's electrical system do not remove processor panels unless an OSHA-approved lockout/tagout procedure is followed. If the processor is cord and plug equipment, unplug the processor before removing processor panels.

LOCKOUT/TAGOUT

Lockout/Tagout procedures must include these steps:

1. **Training for employees conducting servicing or operating or using the processor.**
2. **Employees are notified that servicing or maintenance is required.**
3. **Turn off the processor using the power ON/OFF switch.**
4. **Turn off the circuit breaker at the main power source for the processor.**
5. **Employee servicing processor affixes a lock or identifying tag to the circuit breaker.**
6. **Relieve, disconnect, restrain or make safe all potentially stored hazardous or residual energy in the equipment by methods such as grounding, repositioning, blocking or bleeding down.**
7. **Verify that equipment is disconnected from energy source by pushing the power ON/OFF switch.**



ELECTRICAL HAZARD

HAZARDOUS VOLTAGE CAN CAUSE ELECTRIC SHOCK, BURNS,
OR EVEN DEATH

- Do not connect processor to main power source unless an emergency shutdown switch, which can disconnect all power to the system, is present.
- Do not service electrical components while the processor is in night, stand-by or operation mode.
- Remove all jewelry while servicing equipment.

**ELECTRICAL HAZARD**

HAZARDOUS VOLTAGE CAN CAUSE ELECTRIC SHOCK, BURNS
OR EVEN DEATH

- At the beginning of each week, check all wiring for loose connections and worn or frayed insulation.
- At the beginning of each week check that grounding cable is connected.
- Servicing that must be performed while processor is operating or that requires removing processor panels must be performed by authorized service technicians only.
- When cleaning reservoirs or changing water or liquid chemistry, do not splash liquids on electrical components.

**IN STAND-BY MODE THE PROCESSOR STARTS UP AND
RUNS PERIODICALLY**

PINCHING ACCIDENTS POSSIBLE

- Do not service processor while it is in stand-by mode.
- If the processor is hardwired to the building's electrical system, perform lockout/tagout, according to an OSHA-approved procedure before servicing drive motor and gear train dryer compartment. If the processor is cord and plug equipment, unplug before servicing drive motor or gear train dryer compartment.

**GEAR TRAIN MOVES AND TURNS**

PINCHING ACCIDENTS POSSIBLE

- Keep hands clear of gear train while processor is operating or in stand-by mode.
- If the processor is hardwired to the building's electrical system do not remove guards on the processor unless an OSHA-approved lockout/tagout procedure is followed. If the processor is cord and plug equipment, unplug before removing guards.
- Never operate processor after using mind-altering drugs or alcohol.
- Do not wear jewelry or loose clothing while operating the processor.
- At the beginning of each shift, check mechanical parts for loose hardware and broken parts.

**FIRE HAZARD**

DRYER COMPARTMENT PRODUCES HEAT
PAPER OR OTHER COMBUSTIBLES CAN BE IGNITED

- Keep the area within 10 feet of the processor clean. Do not store combustible materials, including paper, within 10 feet of the processor.
- Clean dust, wood shavings, paper cuttings, waste materials or other combustibles out of the dryer compartment at the beginning of each shift.
- Verify that a functional 10 lb. ABC fire extinguisher is located within 10 feet of the processor.

**BURN HAZARD**

DRYER COMPARTMENT PRODUCES HEAT
DRYER PANELS AND GUARDS GET HOT

- Do not touch dryer panels or guards when dryer is operating.
- Do not lean against dryer panels or guards when dryer is operating.

**CORROSIVE LIQUIDS**

CHEMICALS MAY IRRITATE EYES, LUNGS,
SKIN AND DIGESTIVE TRACT

- Wear safety goggles, protective glove, and chemical aprons as indicated on Material Safety Data Sheets (MSDSs) when handling film chemistry.
- Drain tanks carefully, avoiding splashing. Always drain the system thoroughly before starting any procedure that involves working on one of the fluid circulating systems.
- Read the MSDSs for more information regarding the proper safety procedures for working with photoprocessing chemicals.
- Do not allow untrained personnel to handle photoprocessing chemicals or operate the processor.

CORROSIVE VAPORS

CHEMICAL VAPORS MAY IRRITATE EYES, LUNGS AND SKIN
IF ALLOWED TO ACCUMULATE IN WORK AREA

- The most effective engineering control for prevention of indoor air quality problems is assuring an adequate supply of fresh outdoor air through natural or mechanical ventilation. The American Society of Heating, Refrigeration and Air conditioning Engineers (ASHRAE) recommends 50 cubic feet per minute (CFM) of outdoor air per occupant for darkrooms or 0.5 cfm/square foot, whichever is higher.
- At the beginning of each shift, verify that the exhaust hose for the built-in exhaust blower is connected to the stud in the front of the feed tray box. Verify that the built-in exhaust system is operating.
- Read the Material Safety Data Sheets (MSDSs) for more information regarding the proper safety procedures for working with photoprocessing chemicals.

The specific sequence of tasks necessary to accomplish the installation of the processor are listed in the table below.

Paragraph	Description
3.1	Pre-Installation Environmental*
3.2.	Pre-Installation Electrical*
3.3	When Shipment Arrives**
3.4	Pre-Installation Verification**
3.5	Set Up and Operational Verification

* The customer is responsible for these tasks.

** The customer may be responsible (and so noted) for certain tasks in this paragraph.

3.1 Pre-Installation Environmental (Customer Responsibility)

Ambient Conditions: The processor's operation area should be dust free and maintained at a controlled temperature and humidity. This will help ensure that the best possible output is achieved. The processor's recommended temperature and humidity ranges are: Temperature: 18° to 26°C (65° to 80°F), Humidity: 35 to 75% non-condensing.



Temperature will affect the quality of the copy. If the temperature is consistently out of the specified range, the operator should take appropriate action to provide either heating or cooling of the processor's environment, until the ideal ambient temperature range is achieved and remains constant.

Physical Location: The processor should be placed on a floor that is uniform enough for leveling, and firmly enough to accommodate the weight without movement. The floor should have a hard surface that is easy to clean, e.g. concrete, linoleum, vinyl or hard wood. Do not use carpets near the processor as spilled chemicals will be difficult to remove.

Consider installing the processor on a floor drip tray.

A connection for the air from the built-in exhaust fan should be available to be connected to the processor with max. 6 m of \varnothing 100 mm tube. The exhaust fumes are corrosive and should be ventilated out of the building.

There should be a sufficient working area around the processor to allow the operator or a service engineer accessibility for cleaning, preventative maintenance, or (if necessary) repair. Allow at least 60 cm of working space on all sides of the processor (Fig. 3-A) and the electrical outlet and switch should be placed near the machine on the outside of the darkroom wall.

In a two-room installation the water supply and outlet should be placed on the inside of an darkroom wall if possible. When the processor is fully plumbed, the wash inlet and drain hoses must be straight (no bends in the hoses) when in use.

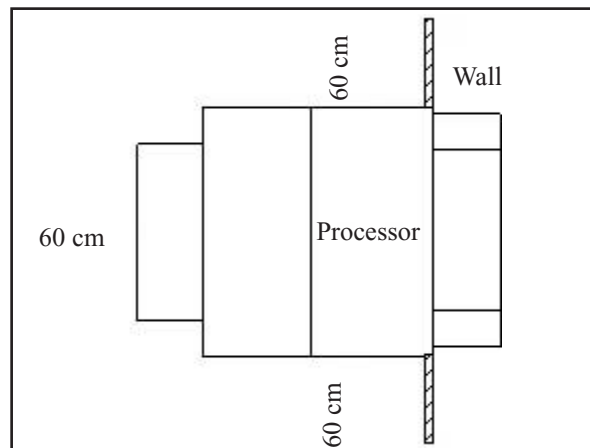

Fig. 3-A

Maintenance Facilities: A sink with hot and cold water, large enough to accommodate the racks, should be installed near the processor. 17"/63 x 30 x 10 - 29"/91 x 30 x 15 - 36"/110 x 30 x 5 - 54"/160 x 30 x 15.

Equipment recommended:

- Drip tray for racks are available from your dealer as optional accessory (see optional accessories in section nine).

- Rack hoist; especially for wider models 91 cm (36"), 114 cm (45"), 135 cm (54"), and models with tank size 2 and 3. (A rack hoist is available from your dealer as optional accessory, see section nine).



Before plumbing, check your local environmental specifications on waste disposal.

a. Water Supply and Hose Information - The water supply to the processor must be at least 0.3-10 bar (4.3-145 PSI - pounds per square inch) with a shut-off valve at its source. It is recommended that inline filters be used in areas where water purity is a problem. Filters should also be considered to prevent the small water inlets from clogging. If the photographic materials to be used require a certain wash temperature then a temperature mixing valve should also be installed.

The hose must be rated and capable of handling a pressure applicable to local building codes. DO NOT use an ordinary hose. The inner diameter of the hose must be at least 3/8" and it must have a female hose fitting to attach to the processor. (The other end is hooked to the building's water supply.)

It is recommendable to install an additional water hose near the tank section for cleaning of the tanks.

b. Floor Drain - A floor drain should be installed under the processor's drain fitting so the drain tubing must slope down from the processor to the drain. Avoid traps created by tubing sag because foam may back up in the tubing, overflow from the standpipes into the processor and contaminate the chemistry.

Do not use brass, copper and aluminium in the processor's drain system. Black iron, tile, ABS, PVC and cast iron are acceptable drain materials. A drain system using a sump pump requires a unit with no brass, aluminium or copper parts contacting the effluent. If a silver recovery unit is used, connect the input on the silver recovery unit to the output on the fixer overflow standpipe. The output of the

silver recovery unit goes to the recollecting container.



Service engineers are not authorized to perform any plumbing other than the connections outlined in the installation procedures of this manual.

3.2 Electrical Pre-Installation (Customer Responsibility)

Operational stability of the processor depends upon proper electrical installation. In accordance with warranty requirements, each processor must be on an individual power distribution branch (dedicated line) that is free of any other equipment.

Voltage and Frequency: The voltage and frequency must be 230/380 V \pm 10%, 50 Hz, 3 phases with ground and neutral. 1 x 230 V \pm 10%/50 Hz or 2 x 115 V + 10%/-0%/50 Hz is available on request, - 60 Hz on request.

Wiring: The processor must be hard wired to the building supply by an electrician. In „through the wall installations“ a breaker should be installed on the right side near the processor. NOTE: proper grounding is essential for safety and operation.

Circuit Breaker: A 16/32 Ampere industrial-rated circuit breaker must be in series with the power distribution hot line so that all wires are dead at the outlet when the breaker is tripped.

Circuit Breakers:

3 phases 230/380 V	3 x 16 A
2 phases 230 V	2 x 32 A
2 x 115 V	2 x 32 A

Optional Transformer: If voltage is outside specified ranges you can order an optional transformer at your dealer.

3.3 When the Shipment Arrives (Customer Responsibility)

Package Inspection: Although the processor is shipped in a wooden crate that has been carefully designed and tested to provide optimum protection, the processor should be examined closely upon delivery to determine if any shipping damage has occurred.

Check all the items received against the order forms, invoices and shipping documents. If missing or wrong items are received or your shipment arrives visibly damaged, sign for the shipment as either “damaged” or “open” and request an inspection by the delivery carrier. In the event of concealed loss or damage notify both the delivery carrier and your dealer. Refer to Paragraph 1.3.



DO NOT return accepted shipments until authorization is established by your dealer. Otherwise, credit and/or replacement may be delayed.

Packages On-Site: The processor shipment should be on-site, in the room where it is to be unpacked and installed. When moving the processor with a fork lift reference the symbols on the outside of the box to ensure it is lifted properly. If the processor package(s) have come from a very cold or very hot shipping environment, allow a sufficient amount of time for the packages to stabilize to room temperature before opening.

3.4 Pre-Installation Verification

Before unpacking, inspecting or installing the processor, the service engineer will verify that the following exist:

- a. A 220 /380 V \pm 10% 50 Hz 3 phase line or a line with the supply ordered and confirmed is available.
- b. Earth grounding of all dedicated lines.

- c. A 16/32 amp fuse or circuit breaker protection for the dedicated line(s).
- d. The processor’s environmental conditions (plumbing requirements included) are within the specifications listed in Paragraph
- e. All shipping containers are in the proper area.

Upon verification of all the above the service engineer should next complete the Set-Up and Operational Verification Procedure. If any of the above conditions do not hold true, advise the customer of your findings and call your dealer for further instructions.

3.5 Set-Up and Operational Verification (Customer and Dealer Responsibility)

Table 3B is the sequential list of paragraphs to complete the set-up and operational verification for the processor.

TABLE 3B
Set-Up and Operational Verification

Sequence	Description
1	Unpacking and Initial Set-Up
2	Operational Check
3	Chemistry Installation



In the event that the processor should ever need moving or troubleshooting, the customer should become familiar with these procedures.

Unpacking and Initial Set Up: When unpacking the unit, take care not to throw away any documentation that is included. Ensure that bits of packing material do not remain in the tanks or roller assemblies.

3.5.a Install the Processor

1. Unpack the Processor

The upper plywood crating is fastened to the pallet by a number of screws along the upper pallet edge. When the screws have been unscrewed with a screwdriver, the upper plywood crating is free of the pallet, can be lifted upwards and then removed from the crate.

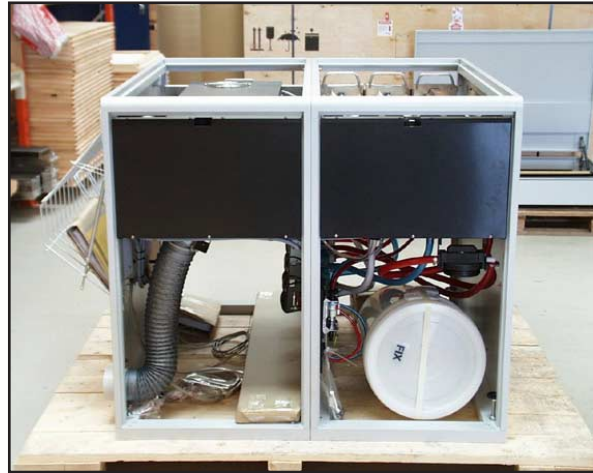

Fig. 3-B. Processor packed on pallet.

2. Dismantle the Processor from the Shipping Pallet

The processor is fastened to the shipping pallet by four transportation bolts. If possible, the processor should remain fastened until the installation location has been reached.

Unscrew the four transportation bolts (wrench # 19), remove the four side panels, the two covers, all racks and slide the processor sideways related to the pallet long edge so that the holes in the bottom frame along the long side of the processor are free of the pallet.

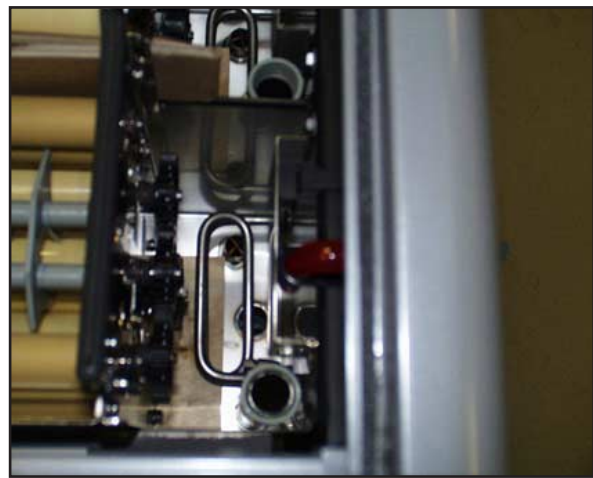

Fig. 3-C. Racks on wood blocks.

Screw in the adjustment bolts (user kit box) until 50 mm (2") remain free under the frame bottom. Use two adjustment bolts under the wet section and one under the rear of the dryer. At each side each adjustment bolt should have one nut and one disc below the frame, and one nut and one disc above the frame inside the processor. Slide the processor further sideways, until the processor tilts by itself. Make sure to hold contra, to prevent damage.

Screw in the remaining adjustment bolt, until 50 mm (2") remain free

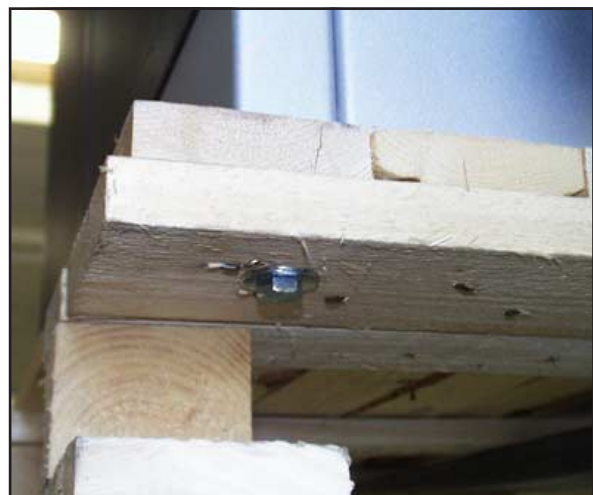

Fig. 3-D. Processor on pallet. Screws are holding it on.

under the frame bottom.

Tilt the processor until the shipping pallet is free and pull it away. Carefully lower the processor again. Slide the processor to the foreseen installation place.

Level the processor by adjusting the adjustment bolts.

3.5.c Processor Split in Sections (Only for two frame models)

If the processor has to come through a narrow doorway it can easily be split in two sections.

Remove the dryer section from the wet section in the following way, fig 3-E to 3-I.

- Remove the two 6MG bolts in the top of each side (Fig 3-E).
- Remove the allen bolts in the bottom of each side (Fig 3-E).
- Remove the cover from the main interconnection box located on the pump bridge and unplug the two plug-in terminals (Fig 3-F and 3-G).
- Unscrew the bolts fastening the pump bridge to the dryer section (Fig 3-H).
- Remove the temperature and the level sensors from the main CPU PCB and pull them out of the box (Fig 3-I).

The two sections can now be split. Assembling is made in the reverse order.

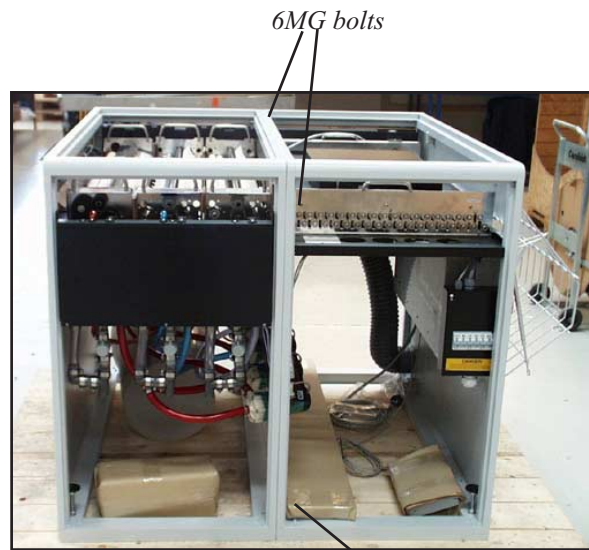

Fig. 3-E.

Allen bolts



Fig. 3-F.



Fig. 3-G.



Fig. 3-H.

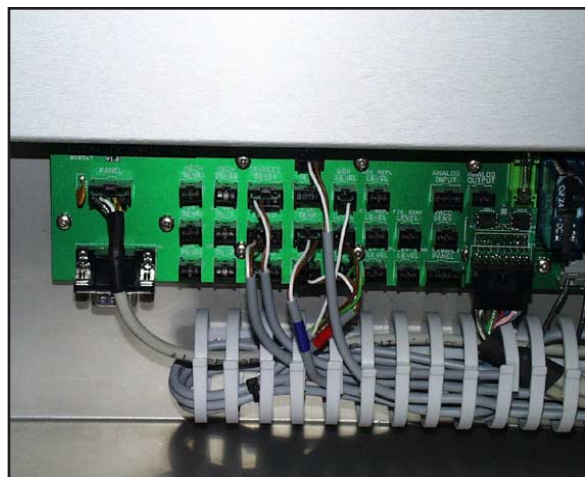

Fig. 3-I.

3.5.e Connect the Processor Hoses

In the bottom plate holes are made to feed all the hoses except exhaust. If the drains are not at floor level the hoses should be fed through the front or rear panel. In these cases holes must be drilled or cut (approx. 19 mm / 3/3" and 32 mm / 5/4").

The seven hoses that should be connected to the processor at the installation are, fig. 3-G, 3-H, 3-I:

- one 3/8" developer replenishment tube (3.5 m is supplied along with the dev. replenishment container).
- one 3/8" fix. replenishment tube (3.5 m is supplied along with the fix. replenishment container).
- a hose approved by the local authorities for water supply must be supplied by the customer. The hose must have a 3/4" female pipe thread at the processor end, minimum inner diameter 3/8" (10 mm). A water supply hose for washing machines or dish washers will often do.
- one water drain hose. Inner diameter 1" (25.4 mm) to be connected inside the processor. Can come out of the processor through the bottom. The hose should be connected to the drain system without any loops. Must be supplied by the customer.
- one developer drain hose and
- one fixer drain hose, both have inner diameter 1" (25.4 mm) to be connected inside the processor. Can come out through the bottom of the processor. The tubes should be connected to recollecting container, which must be



Fig. 3-J

Developer drain connection

Fixer drain connection

Water drain connection

- 1 pc 100 mm diameter hose for exhaust. The hose (supplied by the customer) is secured to the stud on the rear below the receiving basket.

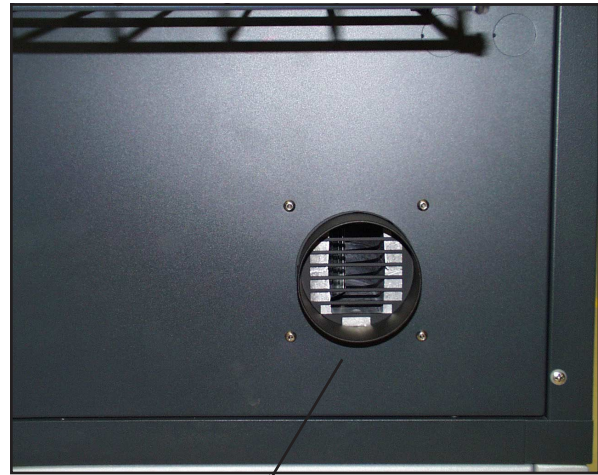

Fig. 3-K

Exhaust hose
connection

1. Inside of the processor below the tank section the hose connections are mount-ed. Place each hose on its respective connection and push all hoses on as far as they will go.
2. Place the hose clamps on the hoses. Slide the hose clamps up to the connections and fully tighten them.
3. Connect and fully tighten the water inlet hose (supplied by the customer) to the 3/4" standard hose fitting below the tank section inside the processor.

Two frame models

Fig. 3-L

Fresh water supply

One frame models

Fig. 3-M

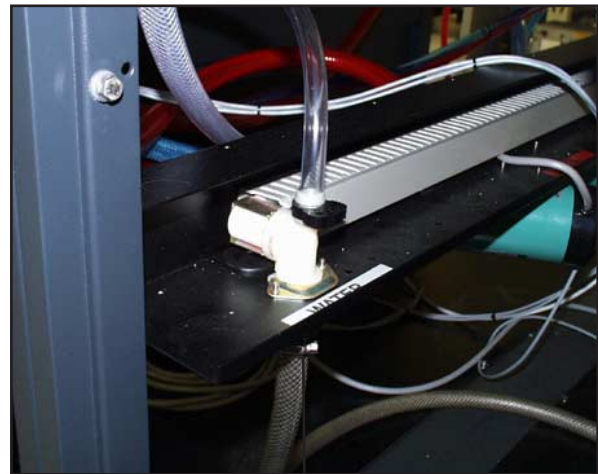
Repl. hose connection

Fresh water supply

Two frame models

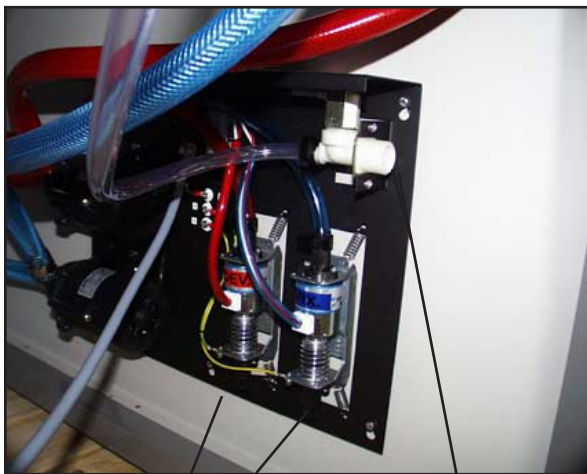
Fig. 3-N

Repl. hose
connection

3.5.f Connect Opposite End of the Hoses

1. Place the fixer (blue) drain hose and the developer (red) drain hoses into two separate recollecting containers (supplied by the customer) near or under the processor. The recollecting containers should have covers with a hole for the drain hoses (covers will help eliminate fumes). ALWAYS use two containers, DO NOT allow any of the drain hoses to bend in any way, cut them to fit (fig. 3-O).
2. Two replenishment containers and two replenishment container covers are supplied with the processor. Place the replenishment hoses onto the angled end of the PVC tube and clamp the hose (fig. 3-P).

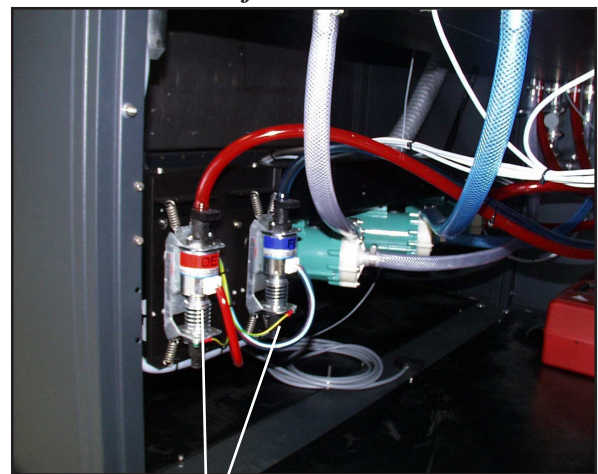
Extending the replenisher hoses will affect the capacity of the replenishment system. Extending the tubes may only be allowed depending on the amount of replenishment needed by the specific chemicals and photographic job. A higher setting than normal of the replenishment dial may be necessary. Using larger diameter hoses will minimize the effect of long hoses.



Cut the drain and replenishment hoses as short as possible. A shorter hose will prevent problems with replenishment and draining.

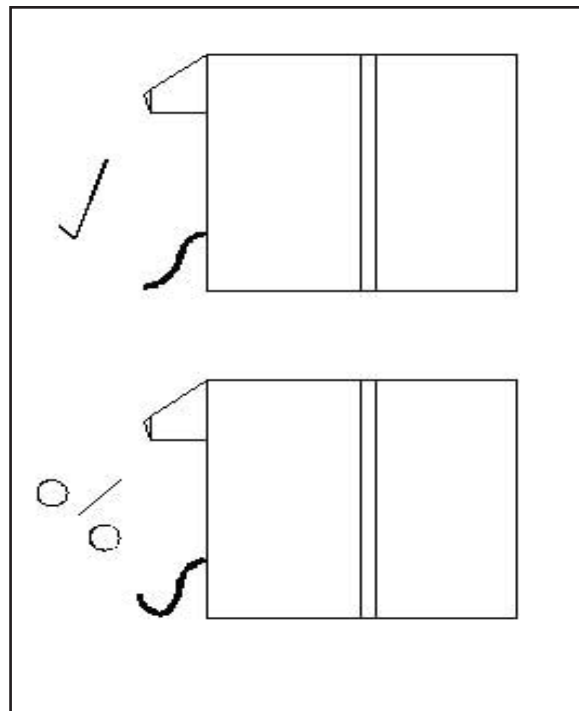

Fig. 3-O

3. Connect and fully tighten the water inlet hose to the water supply. DO NOT TURN THE WATER ON AT THIS TIME!
4. The 100 mm diameter exhaust hose should not be longer than 6 m and should run out of the building with as few bends as possible. If the distance out of the building is too long, extra fans in cabinet 250199 should be ordered.

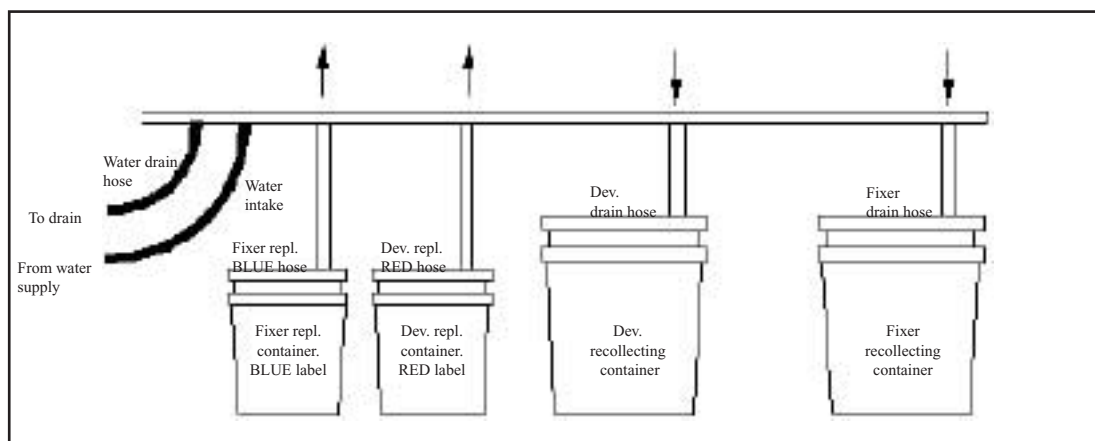

Fig. 3-P

3.5.g Connect Electrical Power

1. Remove the two screws holding the cover over the power box, fig. 3-Q.
2. Feed the power cable through the bottom plate and in through the hole in the bottom of the power box.



Fig. 3-Q Feed power cable through

Each processor is delivered with three short-circuit beams, fig. 3-R1, which can be mounted according to the power connection at the customers. At delivery, the processor is equipped with short-circuit beam #1. This short-circuits N1, N2 and N3 for three phase connection with one neutral (Europe).

If single phase connection is required, slide short-circuit beam #2 into short-circuit #1, which results in a short-circuit of L1, L2 and L3. Hereafter, just connect the phases to L3 and N3.

If three phase connection without neutral is required (USA, Norway) mount short-circuit #3 and connect the phases to L1, L2 and L3.

Please also turn to chapter 7, page 75.

3. Reinstall the cover for the power box by its two screws, fig. 3-Q.

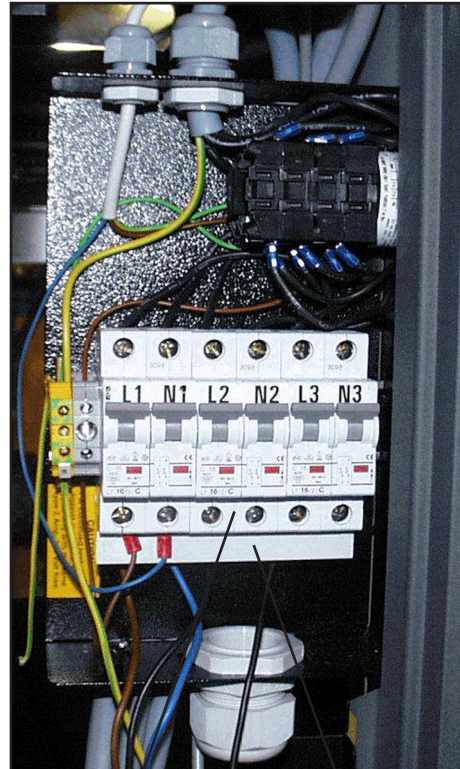

Fig. 3-R Main connection terminal block short-circuit beam

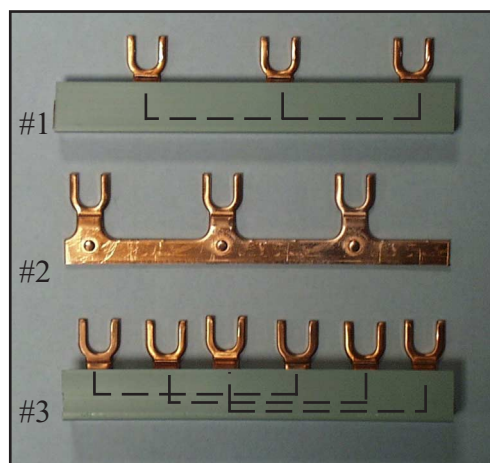

Fig. 3-R1

3.5.h Clean Trays

With a damp sponge clean all three tanks. Be sure to remove all dust and shipping debris before operating the unit.

3.5.i Level the Processor

1. Ensure the processor is in its permanent location.
2. Carefully pour water (do not splash) into the developer tank until the overflow level is reached. Use the rollers to visually level the processor, from right to left. From front to back a spirit level must be used on top of the frame.
3. If levelling is necessary use the #19 open end wrench to adjust the processor's levelling feet, (fig 3-S), until the water appears level. (Rotating the wrench in a clockwise manner will raise the processor). All levelling feet must make contact with the floor so that rocking cannot occur.



Fig. 3-S

Levelling feet

Unpacking and Set-up is Complete. Perform the Operational Check Procedure

3.6 Operational Check:

The operational check ensures that the system is operating properly.

Important Notes:

- It is **IMPERATIVE** that the processor is flushed with water before chemistry is installed. Therefore, the operational check procedure requires the use of water (not chemistry).
- **NEVER RUN THE PROCESSOR DRY!**
- Exercise extreme care when operating the processor with the cover open. Keep clothing and jewellery away from the media transport and terminal block areas.

3.7 Chemistry Installation:





NOTES:

1. Safety glasses, a chemical apron and rubber gloves should be worn when changing chemistry.
2. To Prevent chemical contamination. Never allow chemistries to intermix.
3. Always change the fixer first as this will help eliminating the possibility of chemical contamination.
4. See section four for chemical disposal information.
5. The processor should be rinsed with water each time the chemistry is changed (see section five).
6. Cap any unused chemistry and check replenishment containers every morning.

Chemistry Installation Procedure

Chemistry Installation

- a. Fill the replenishment containers with fixer and developer chemistry.
- b. Make sure that the level sensors do not touch any part of the processor.
- c. Turn on the processor. After it has initialised it will start to refill DEV, FIX and WASH. After 1 minute an error message will show “ DEV / FIX or WASH level low. Enter the DEV/FIX or WASH menu, now the refill button  will be active. Press the  button to refill the selected tank. Exit and follow above instructions for the other two tanks.

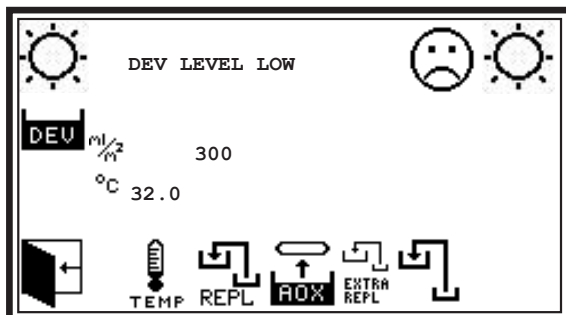

DEV level low error message

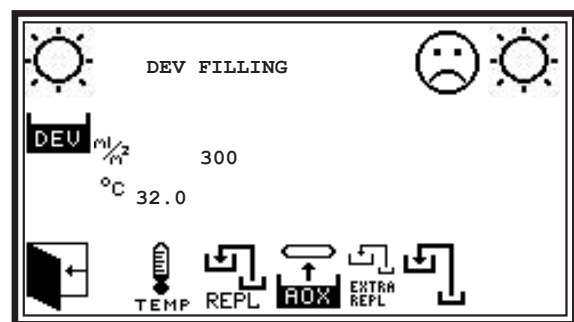

DEV filling message

It takes up to 15 min. to fill up the tanks. When they are full the pumps will automatically stop as the level sensors are activated. If the pumps run dry they will „time out“ after a while.

By pressing  again you can suspend the filling process. That is used if the replenish bin need to be filled up.

- d. When all tanks are filled up wait for the chemistry to heat up. This takes approx. 30 minutes.

To continue the operation go to section 4.10

4.1 General

This section contains the processor’s basic operating instructions and guidelines with respect to photographic supplies.

 Before operating the processor, the procedures in section three installation must be performed. Read this entire section before attempting to operate the processor.

4.2 Night/Stand-by/Process

Various system components will be operational in each of the three modes. The Night/Stand-by/Process table below illustrates the operational components in each mode.



The three states, which the processor can

be in, are shown at both the right and left top of the panel.

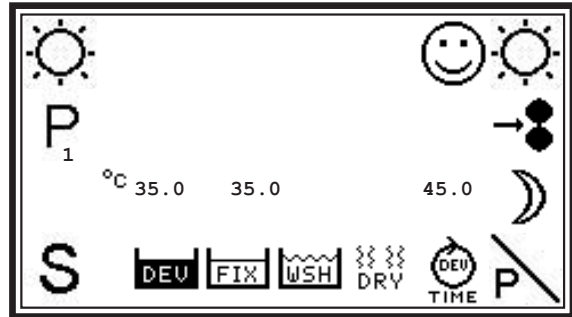
The panel shown below is normal stand-by mode.



Night/Stand-by/Process
(With main power switch ON)

Night 	Stand-by 	Process 
Dev./Fix. heat ON/OFF. Optional Circulator pumps ON by heat Level control: when a low level is present - heater in the actual tank turns OFF, Dev./Fix. is replenished (max. 70 seconds). Low level message flashes and tank with low level is showed.	Dev./Fix. heat ON/OFF. Circulator pumps ON Level control: when a low level is present - heater in the actual tank turns OFF, Dev./Fix. is replenished (max. 70 seconds). Low level message flashes and tank with low level is showed. Manual replenishment possible. Preset speed, temp and prg. displayed. Dev./Fix. and Dry temperature can be displayed.	Dev./Fix. heat ON/OFF. Circulator pumps ON Level control: when a low level is present - heater in the actual tank turns OFF, Dev./Fix. is replenished (max. 70 seconds). Low level message flashes and tank with low level is showed. Manual replenishment possible. Preset speed, temp and prg. displayed. Dev./Fix. and Dry temperature can be displayed.
AOX ml/h & %24h Optional Drive motor running slow if motor creep is enabled, otherwise it will be off. Screensaver active after 15 sec. Clock displayed in panel Exhaust fan ON.	AOX ml/h & %24h Drive motor running slow if motor creep is enabled, otherwise it will be off. Dryer: The pre-set standby temperture is obtained. Exhaust fan ON.	AOX ml/h & %24h Water valve ON. Drive motor ON at the preset speed. Dryer: The pre-set operat temperture is obtained. Continuous replenishment ON while material is present at feed sensor. Except if speedway is activated. (only some imagesetteres!) Exhaust fan ON. After the material has been processed the processor will return to Stand-by

4.3 Temperature/Speed/Replenishment

Depending on the chemistry used and the materials being processed, the operator-accessible temperature, speed, and replenishment may need adjusting. Adjustment of each of the controls will have an affect on the output copy (see section one controls and indicators). The control panel settings table recommends the ideal temperature, speed and replenishment settings with respect to the chemistry and material being used.



Temperature will affect the quality of the result. If the processor's ambient temperature is consistently higher than the set temperature the operator should take the appropriate action to provide cooling of the processor's environment until the ideal ambient temperature range is achieved and remains constant.

*** 4.4 Replenishment Settings**

The replenishment must be proportional to the amount (area) of film passing the processor and it depends on the overall average density.

The area of film processed is determined by the input sensors. Every time a certain amount of material (15-60 cm depending on model and film width) has passed the input sensors the replenishment system is activated. The duration of the replenishment programme can now be set by the operator depending on film width, overall average density of the film and the necessary max. replenishment per m² of 100% black as informed by the manufacturer of chemicals.

The use of chemistry needed may variate from manufacturer. Please contact your supplier for further information

4.5 Daily Operation

Performing the basic daily operation guidelines outlined below, along with preventive maintenance, will aid in the trouble free performance of the processor.

4.6 General Operation

1. NEVER RUN THE PROCESSOR DRY!
2. Remove the top cover over the wet section whenever the units power supply is turned OFF. This will prevent chemical condensation inside the processor.
3. Always turn the building's water supply to processor OFF at night if the automatic drain/refill function of the water tank is not used.
4. Check hose connections, tighten any that may have come loose.
5. Keep processor **CLEAN!** Keeping the processor clean (inside and out) will produce better results and extend the life of the processor and components (see section five).

4.6 b Each Morning

1. Check the level in the developer and fixer tanks.
2. Check the replenishment containers and refill if necessary.
3. Wipe off any dried or spilled chemistry.
4. Turn the processor ON and put the processor into night mode.
5. Turn ON the water supply to refill the wash station.
6. Place the top covers on the processor.
7. Verify the temperature when the warning goes out.

8. When the set temperature is achieved put the processor into day mode and process a piece of "cleaning film" in the full width of the processor to clean off any dirt or dried chemistry that may have settled on the rollers overnight.

4.6 c The End of a Work Day

1. Turn the water supply OFF.
2. Turn the processor OFF.

4.7 Processing

General: When the chemistry is installed and the heater lamps are out the operator may set the speed control, check the temperatures, set the replenishment rates, press the mode switch to stand-by, fold the paper and insert the paper into the processor.



The processor will NOT go into PROCESS MODE if a low chemistry/water level exists or if the processor is in night mode.

Processing Procedure

- a. Place the processor in day mode.
- b. Adjust the transport speed to the desired rate.
- c. Check the temperature of the developer and fixer.
- d. Set the developer and fixer replenishment rates.
- e. Fold the leading edge of the phototype-setting paper and then insert it under one of the sensors as straight as possible. The photo sensors are activated by the material, causing the processor to go into process mode. When processing sheet film, place the film on the feed table and insert it into the processor as straight as possible. The film photo sensor will be activated.



Sheet film, except daylight film, requires processing in a darkroom.

- f. After the material completely exits the processor remove it from the receiving basket.

4.8 Changing Exhausted Chemistry

Chemistry life is greatly extended by the processor's stand-by and AOX features. The chemistry change table provides the approximate chemistry life with respect to the materials processed.

TABLE 4B
Chemistry Change Schedule*

Material	Frequency
Phototypesetting paper	every 1-2 months
Line or Daylight film	every 1-2 months

* These are only recommended times. Ambient conditions vary, therefore the frequency of your chemistry changes may have to be altered. The chemistry should also be changed before or when the operator observes:

- Phototypeset copy characters and lead edge appearing grey rather than black.
- Pinkish tint on film or paper background.
- Phototypeset copy characters face with time (contaminated/dirty wash). Change wash water more frequently.



Grey characters can also be caused by a low typesetter intensity or a low developer temperature. (If the galley's lead edge is black, check typesetter).

Always recirculate clean warm water and clean the roller racks whenever the chemistry is changed. (See section five Maintenance).



By their nature and consistent with the best manufacturing processes we employ, some of the chemical products you purchase may be subject to certain laws regarding their proper handling and disposal. You should familiarize yourself with our material safety data sheets and with any laws which may be applicable to wastes generated from use of our products or resulting from the discard of any products unused.



Overexposure to photographic chemistry may cause skin irritation to certain individuals.

PHOTOGRAPHIC CHEMISTRY EMERGENCY AND FIRST AID PROCEDURES:

- SKIN - Flush thoroughly with water.
- EYES - Flush thoroughly with water and consult a physician.
- INGESTION - Consult a physician immediately.

4.9 Panel Operations

The EG, EP and EGP processors are equipped with Celis Control, which is an advanced micro processor controlled unit with a LCD screen user interface. The Celis Control consists of two computers: one that controls the processor itself and one, which enable you control the processor (the control panel). It has a lot of functions, which will be explained in this section.

Along the lower and right part of the panel, there are membrane push buttons. The icon closest to the button shows which function the button has. If **FIX** is pushed the functions regarding the fixer bath are shown in the panel.

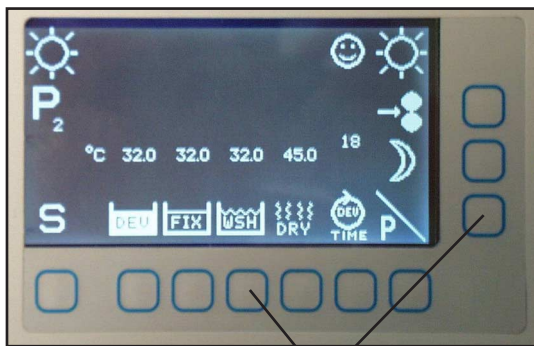

Fig. 4B

Standby screen push buttons
Inside the Celis Control there is a little guy named Celis. He is normally happy but if he is worried or unhappy, he will let you know.



Happy: Everything is OK. Film feeding is possible and ready signal is transmitted to the imagesetter, if connected.



Worried: Nothing is wrong, but the processor is in a state where it is not possible to feed material. Not ready will be transmitted to the imagesetter, if connected.



Unhappy: Something is wrong and Celis will tell you what is wrong in the display. It could be low temperature, low chemistry level or some other things. Not ready will be transmitted to the imagesetter, if connected.

4.10 Shifting between Modes

When the processor is switched on the computer will initialize and transfer settings between the main computer and the panel. This operation takes approx. 30 seconds. When finished it will enter the stand-by mode.

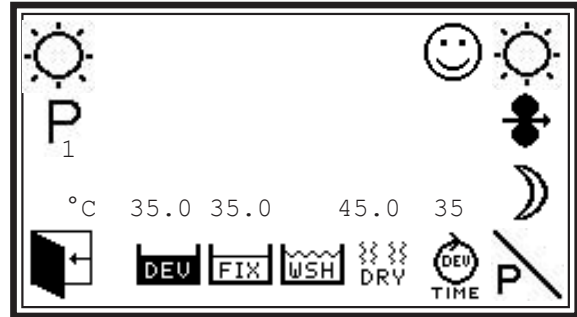

Stand-by mode

If night mode is wanted, just push the button close to the night  icon and the processor will enter night mode.

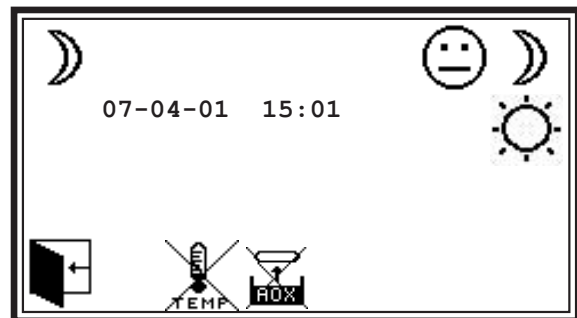

Night mode

It is also possible to force the processor into process mode by pushing . The drive motor will start and both the upper and lower part of the dryer section will be ON.

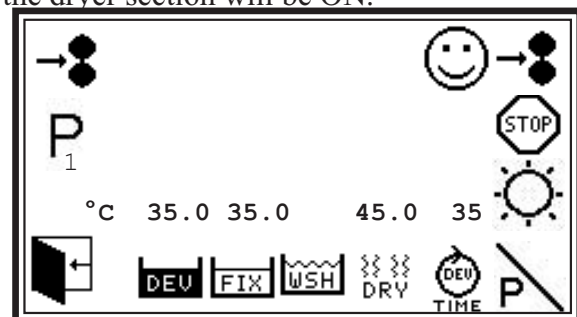

Forced process mode

Leave the forced process mode by pushing

4.11 Setting up the computer - Region

When the processor is delivered the computer has to be set up for your requirements. That means temperature, speed, replenishment and AOX rates, clock and language.

The region settings can be changed by pushing **S** & then ☀️. The screen will now look like this:

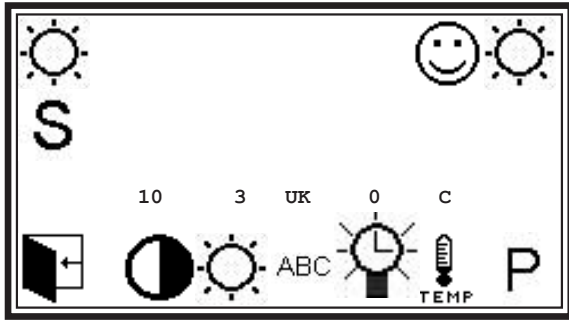

Region settings

The region settings can now be changed:

- Changes the contrast in the display
- Changes the brightness in the display
- ABC Changes the preferred language. UK - English, D - German, F - French
- Adjust the back light Off time. "0" is always on. 180 = 3 min.
- TEMP Changes between Celcius and Fahrenheit
- P Select the number of active programs

Choose your personal needs. When finished, push twice to return to the normal stand-by screen.

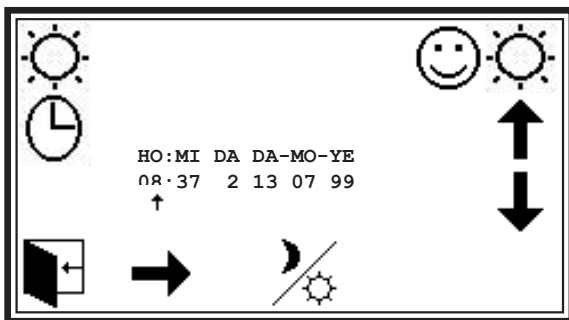

Clock and date adjustment

The arrow is used to choose which parameter should be changed. When pushed the small arrow will move to indicate which parameter can be changed, use the two arrows on the right to increase or decrease parameters.

The day setting is as follows:

- 1 Monday
- 2 Tuesday
- 3 Wednesday
- 4 Thursday
- 5 Friday
- 6 Saturday
- 7 Sunday

The rest should be straight forward.

When finished push twice to return to the normal stand-by screen.

4.12 Setting up the Computer - Changing Programme Entry Number

You can set up six different programmes containing different settings for each parameter. To choose which program to set up, press the button **P**. Notice that the big "P" on the panel will change number showing the programme number, which is currently active.

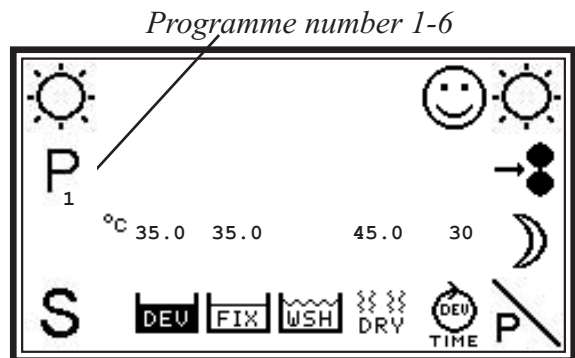

Change program by pushing **P**

When the program number is chosen the settings can be changed.

4.13 Setting up the Computer - Temperature, Replenishment and AOX

To change temperature and replenishment rates for developer, push **DEV** and the screen

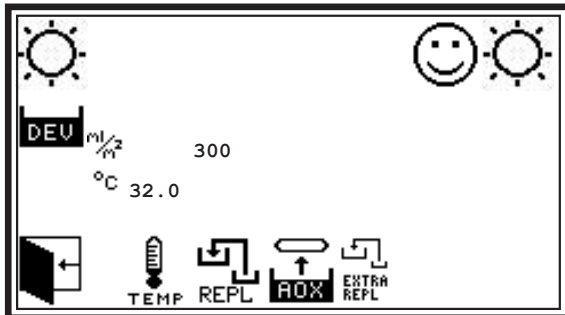

Settings for developer

The screen now shows the current settings which are 32.0 degr. Celcius and 300 ml/m² replenishment for developer.

To change the temperature, push **TEMP** and the display will look like this:

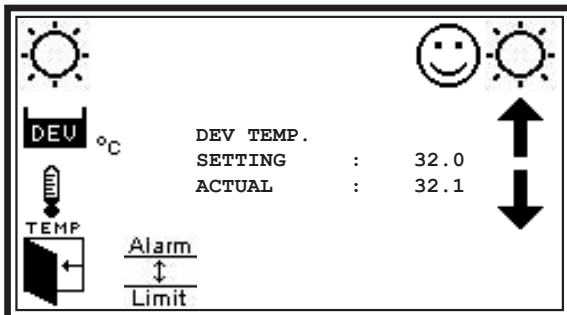

Developer temperature adjustment

Setting shows the desired temperature in the developer bath and actual shows the actual temperature is in the developer right now. If the processor has been on for a while, the max. difference between the two figures should be 0.2 degr. Celcius, or less.

To change the setting use the two arrows on the right side **↑ ↓**.

To set up the dryer temperature please see section 4.19

Choose alarm limit $\frac{\text{Alarm}}{\text{Limit}}$ and the screen will look like this:

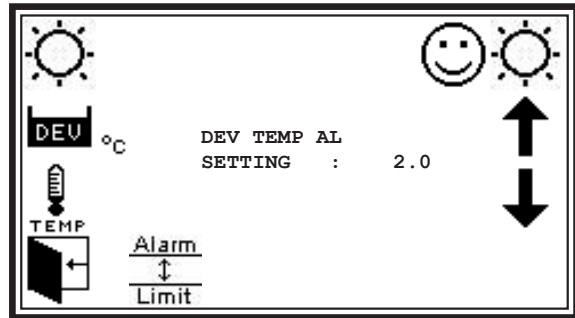

Alarm limit adjustment

The alarm limit is a function, which will give you and the imagesetter, if connected, a warning if the actual temperature is out of a certain limit. To change the setting, use the two arrows on the right side **↑ ↓**. The range is 0.5-5.0 degr. Celcius.

Use the back key **←** twice to go back to the *settings for developer* screen.

To change the replenishment rate for developer push **REPL** and the screen looks like this:

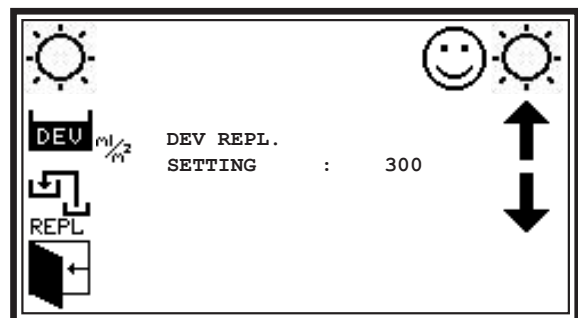

Developer replenishment adjustment

The amount of replenishment can now be adjusted. To change the setting, use the two arrows on the right hand side **↑ ↓**.

Use the back key **←** once to go back to the *settings for developer* screen.

Push  and the screen looks like this:

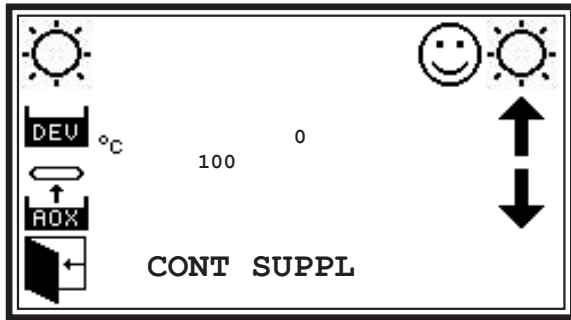

Developer AOX setting

AOX Definition

There are two ways to control the AOX. The amount of chemistry that the processor should supply can be entered as:

1. ml per hour,
or/(and)
2. percent of the tank volume that should be replaced over a 24 hour period.

To change any of these two setting, push the ^{CONT} button or the ^{SUPPL} button.

On most processors there is only one pump for dev. repl., which is used both for replenish for films feed through the processor and for antioxidation replenish (AOX)

The two programs will individually calculate replenishment and add to the same software counter.

The Celis software has a variable that indicates a “replenish portion size”. The min. portion is 200 ml. (before Sw version 2.06 100 ml).

The processor will add 200 ml every time the “software counter” indicates that 200 ml or more has to be added . This means the pump will always pump a portion size dividable with 200 ml. Ex. if the program is adjusted to 500ml/m² the pump will always pump 200 ml, but the pump will start more often than if it was set up to 100 ml/m².

ml/h:

When the processor has been in stand-by in 20 min. 1/3 of the adjusted value is added to the “software counter “. Every 20 min. in stand-by, the processor will repeat this. When this “sw counter” exceeded “ 200 ml”. The processor will pump 200 ml into the processor. When the processor is switched off the counter is reset.

% tank capacity /24 h.:

20 min. after the processor has been switched on, the processor will check that the set up percentage of a full tank volume that has been added the last 24 hours. In the calculation it will include both replenish and AOX (ml/h) and % tank capacity /24 h. If the set up value has not been added, the processor will add 1/72 position to the “software counter”. It will repeat this every 20 min. When this “sw counter” exceeded “ 200 ml”, the processor will pump 200 ml into the processor. When the processor is switched off, the counter Use the back key once to go back to the settings for developer screen.

If the  is pushed the computer will supply 400 ml of developer into the tank. This manual replenishment function, can be used to top off the tank:

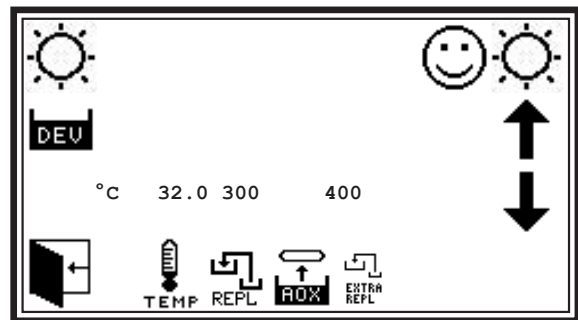

Alarm limit adjustment

Manual replenishment active

The temperature and replenishment setting for fixer is done the same way. Dryer temperature is done the same way as for developer and fixer temperature.

Use the back key  to return to the standby screen

Setting up the Computer - Developing Speed

To change the developing speed, push

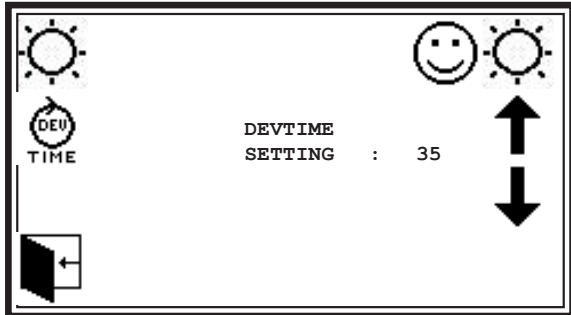

Developer speed setting

Developing speed means the time that the film spends in the developer bath, and only developer bath. The travel through the entire machine will take approx. 4 times as much time.

To change the setting, use the two arrows on the right side .

4.14 Setting up the Computer - Timer Setup

The computer is equipped with a timer, which can switch the processor on and off up to two times a day. If your processor has a water drain valve mounted, the timer can also drain your water tank automatically to avoid algae growth in the tank.

To enter the timer setup, press **S** - - - .
The screen will look like this:

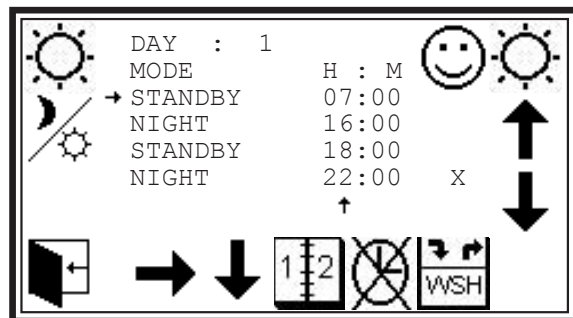

Timer setting

The above screen tells that the processor will enter stand-by mode at 07.00 Monday and back to night mode at 16.00. At 18.00 the processor will enter stand-by again and turn back to night mode at 22.00. At 22.00, when the processor enters night mode, the processor will also drain the water tank. The tank will be filled up again 1 hour before entering stand-by

To change the settings, use to choose the day, the button to choose between hour/minute, the to enable/disable the drain water tank function (if mounted) and the right arrows to change the hour/minutes.

If a setting is not wanted can be used to erase the setting.

4.15 Setting up the Computer - General

The computer saves statistics, which can be viewed. Push **S** - . The screen will look like this:

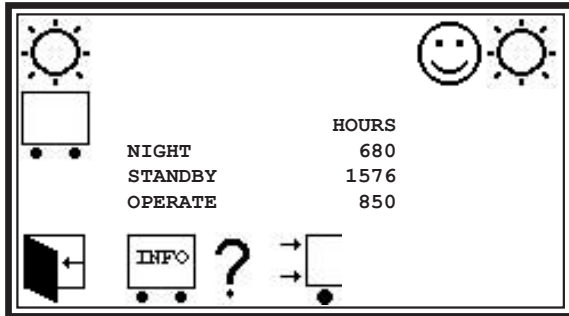

Statistics

In this case we can see that the processor has been in night mode for 680 hours, stand-by mode for 1576 hours and in operate mode 850 hours. This is simply used to get an idea of how much the processor has been used since installation.

Push and the screen will look like this:

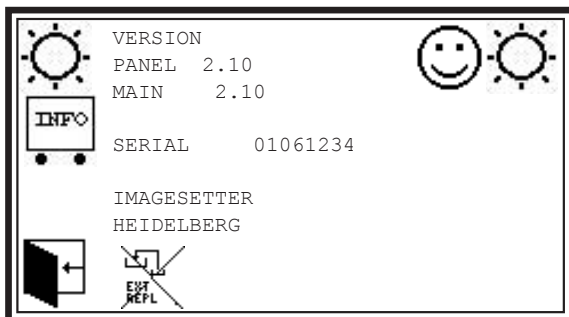

Software version and serial number

Replenish via speedway activated.
(Only Primesetter)

Replenish via speedway not activated.

This screen shows the software version for the panel and the main computer. It also shows the serial number of the processor. Always have the serial number at hand when calling your supplier for assistance.

To find out who to call if you need help or have questions use the **?** button and the screen will display your suppliers name and contact phone number:

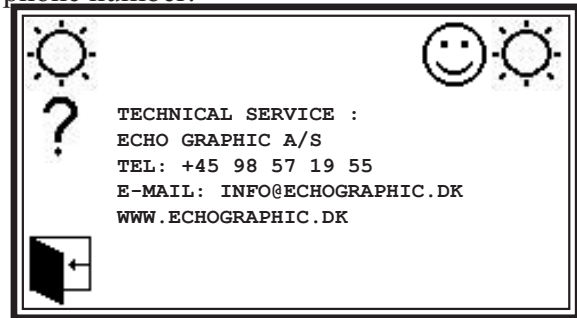

Supplier information

When calling for help or answers you may be asked to enter the input information screen.

Use to enter this information screen:

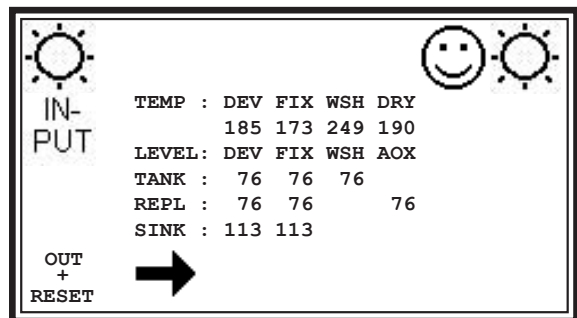

Information screen 1

This screen displays information about temperature and level sensors. Use to enter the next screen:

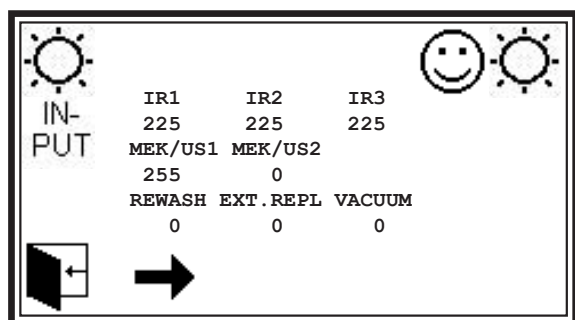

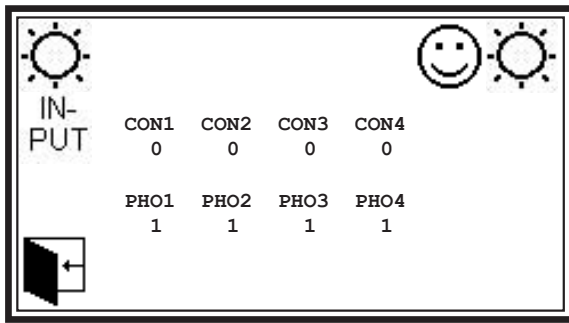

Information screen 2

This screen displays information about the input-sensors and other sensors. Use to enter the next screen:



Information screen 3

This screen displays information about signals coming from and going to the imagesetter, if connected. These three screens can be very helpful to locate a problem on the processor.

When finished viewing the use the back button  twice to go back to *information screen 1* and leave by using .

The computer will now perform a reset, which will bring the processor back to stand-by mode within approx. 30 seconds.

4.16 Setting up the Computer - Day Operation

It is now time to feed a film into the processor. Before doing this make sure the processor is ready and in stand-by mode:

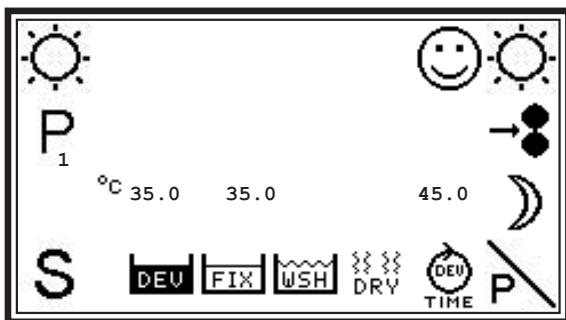

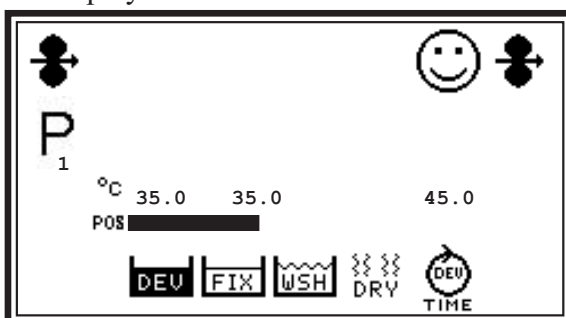

Stand by mode

Introduce a film into the processor and observe the display:



Operate mode

Notice that  is indicated in both upper corners showing that there is film under the input sensor. When the film has passed the input sensor the symbol will change to  showing that the processor is ready for the next film:

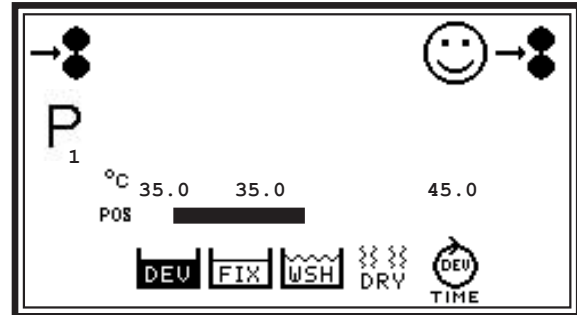

Ready for the next film

Also notice the bar moving next to the POS . This bar indicates the position and length of the film inside the processor.

When the film has left the processor the processor will return to stand-by mode.

As long as there is film inside the processor, it is possible to enter dev. and fix. settings, but it is not possible to change anything, only observe.

 To stop the processor press the lower right button 5 X. It will then return to stand-by. If an inlet sensor is activated it will restart!

4.17 Error Messages

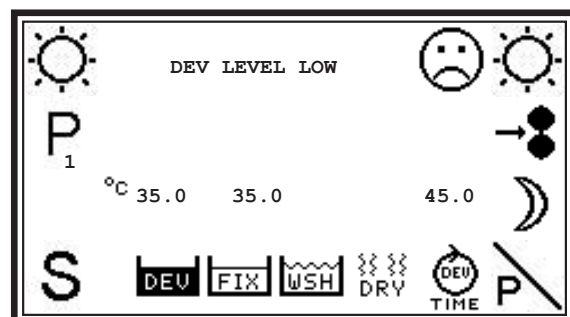

Error Message



The computer is monitoring all the sensors in the processor all the time. If something fails, the computer will let you know by displaying the fault and Celis will be unhappy:

The computer will also give an acoustic message every 10 minute.

If an error appears, it is not possible to introduce a film into the processor. It will not start and a not ready signal will be sent to the imagesetter, if connected, and further jobs will not be sent.

Correct the error displayed and the processor will return to stand-by mode. Please see appendix for an complete list of messages.

4.19 Setting up the Dryer temperature

To change the dryer temperature for stand-by and the process, replenishment rates for developer push  followed by  and the screen will change:

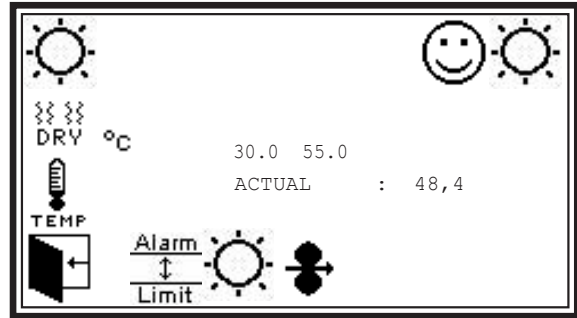

Dryer temperature adjustment

4.18 Daily Maintenance Messages

The computer will remind you to maintain your processor. Only through regular maintenance, you can achieve trouble free running of the pro-cessor. Below is an example of one of these maintenance messages:

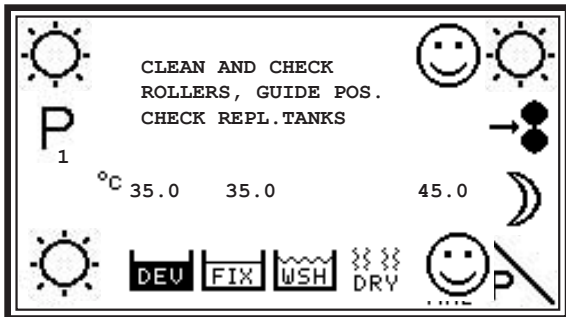

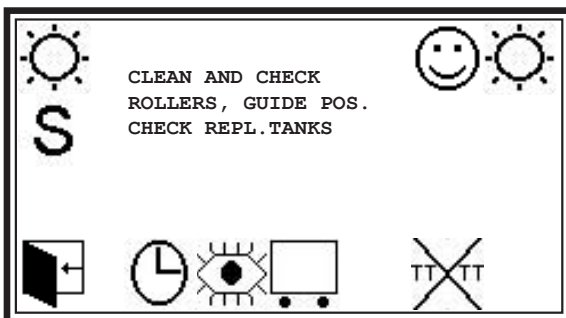

Maintenance messages

When a message is shown at the display and the suggested operation is done, the message has to be cleared. This is done by pushing and the display will look like this:



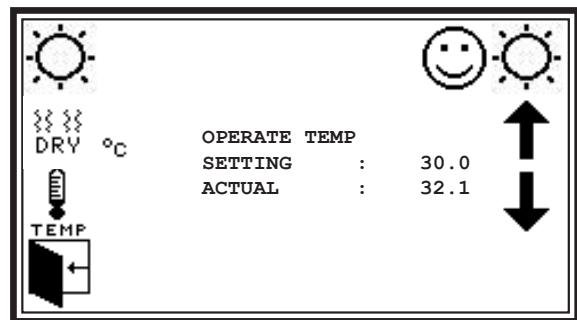

Now press  and the message will be

Select  to change the standby temperature or press  to change the process temperature and the display will look like this:



Dryer temperature adjustment

Setting shows the desired temperature in the dryer and actual shows the current temperature in the dryer. If the processor has been on for a while the max. difference between the two figures should be 5 degr. Celcius or less.

To change the settings use the two arrows on the right side  . Use the back key  to go back.

The  key can be used to change the alarm limit.

5.1 Introduction

This section explains the general and specific tasks which must be performed during preventive maintenance, mechanical/electronic adjustments and troubleshooting.

Before performing any task read the entire subsection thoroughly. By doing so you will gain a better understanding of each procedure plus tools and/or parts, which may be needed.

If a procedure is labelled for technicians only, either a trained service engineer or a qualified technician should be called to perform the procedure.

Finally, always take care when performing any procedure - ***SAFETY is the most important concern. Always turn off the main switch and lock by a padlock (where stated) before starting a procedure. Always drain the chemistry when working on the recirculation system.*** Never allow loose clothing or jewellery to come into close proximity with the gear train or media transport area.

5.2 Preventive Maintenance

(Customer Responsibility)

The objective of preventive maintenance is to maintain the reliable, trouble free performance of the processor. There are specific preventive maintenance tasks, which must be performed on a scheduled basis to meet this objective. These tasks are identified in Table 5A.

Table 5A

Recommended Preventive Maintenance Schedule

Daily Maintenance

- Clean the feed tray or inlet if it is an on-line processor.
- Clean all rollers and guides above liquid level with a wet sponge. Check that the guides again are in correct position.
- Check the replenishment tanks every morning, the pumps may not run dry. Remember hardener in fixer.
- Before start of processing check that temperature, speed and water flow are correct.
- Run a cleaning film through the processor every morning to ensure that the chemical activity level in baths is correct.
- Check that the exhaust system is working.

Weekly Maintenance

- Clean the processor for chemical stains with a wet cloth or sponge.
- Empty the wash tank before the weekend and refill after the weekend to avoid algae growth.
- Only use anti-algae agents without chlorine (bleach) and clean as required.

Preventive Maintenance *)

- Good developing quality and trouble free processing are conditioned by regular cleaning and maintenance. Use only qualified personnel.
- Exchange chemistry and clean racks and tanks with warm water max. 40°C.

*) Every 2-4 months, depending on how intensively the processor is used.



A maintenance record should be held in order to control the change of chemistry and cleaning. This should be filled in every time a maintenance function is performed. This will aid the operator in processor operation and technical personnel to know if the processor needs servicing.

CLEANING PROCEDURES*(Customer Responsibility)*

5.2.a Water Cleaning: The processor should be rinsed with water every time the chemistry is changed. The roller racks and tanks should also be cleaned at this time. This cleaning will not only keep the processor and output copy clean, but also aid in the prevention of chemical contamination.

Water Cleaning Procedure

Equipment

required: - Soft bristle scrub brush
- Paper towels

Equipment

recommended:- Drip tray for racks
(available from your dealer as optional accessory - see optional parts list, section 9).
- Rack hoist, especially for wider models: 91 cm/36", 114 cm/45" 135 cm/54" and models with tank size 2 and 3.
(A rack hoist is available from your dealer as optional accessory - see optional parts list, section 9).

1. **Turn the main power switch OFF and remove the top covers.**
2. Ensure the drain containers are in place and are empty enough to accommodate the chemistry being drained. Open the drain valves and drain the chemistry, table 5B

X	75X"	90X"	114X"
0	29L(16L)	(18L)	
1	26L	29L	36L
2	39L	50L	

Table 5B (polyester)

3. When the chemistry is completely drained, close the drain valves. Place the developer and fixer drain hoses into the drain.

4. Dispose all chemistry in the replenishment containers. Fill the replenishment containers with clean warm water and reconnect them to the processor.
5. Fill the developer, fixer and wash stations with clean warm water.
6. When positioning the mode switch in day operate, position and place a piece of film (paper) under the inlet sensor. The film should not engage the inlet rollers. Turn the main power switch on and set the dev. and fix. replenishment dial to max. Leave the main power switch on for approx. 15 minutes.
7. When the 15 minute rinse is through turn the main power switch OFF.
8. Drain the water from the three stations.
9. Remove the roller racks one station at a time.
10. Clean the roller rack with warm water in a sink. Use a soft bristle scrub brush to remove any chemical crustation or sludge.
11. Using paper towels, wipe out the tank. Ensure no bits of paper are left in the tank. If deposits are beginning to build up in the first station, then the processor should be cleaned with universal processor cleaner.



Discoloration of the rollers is normal, especially in the developer rack.

12. Return the roller rack to its proper station (identified by label).
13. Repeat tasks 9 through 12 until all stations have been cleaned.
14. Place the developer and fixer drain hoses back into their recollecting containers.
15. Add chemistry in accordance with the chemistry installation procedure in Section Three.
16. Replace the top covers.
17. Complete the processor maintenance log.

Chemical Cleaner: When chemistry is changed or if deposits are observed in the first tank station, the customer should clean the processor with universal processor cleaner. The chemical cleaner removes normal chemical build-up from the pumps, hoses and tanks.

To order the processor cleaner, contact your dealer.

5.2.b Dryer Roller Cleaning: The entrance dryer rollers should be cleaned each time the processor is rinsed with water (or every chemical change).



Always turn off the main switch and lock by a padlock when cleaning the dryer rollers.

Dryer Entrance Roller Cleaning Procedure

Equipment Lint-free cloth
required:

1. *Turn the main power switch OFF and lock by a padlock.*
2. Use a lint free cloth dampened with water to wipe down the surfaces of the dryer's two entrance rollers.



DO NOT spray any water or cleaning solution on the surfaces of the rollers. Dampen the cleaning cloth with water only.

5.2.c External Surface Cleaner: The external surfaces of the processor should be cleaned on a periodic basis or any time the surfaces come in contact with chemistry.



Always turn off and lock the main switch when cleaning the external surfaces.

External Surface Cleaning Procedure

Equipment Lintfree cloth
required: Mild detergent



DO NOT spray any cleaning solution on the surfaces of the processor. Dampen the cleaning cloth only.

1. Turn the main power switch OFF and lock by a padlock.
2. Use a lint free cloth dampened with a mild detergent to wipe down all external surfaces.
3. Allow all cleaned surfaces to **DRY** before turning on the power again.

5.3 Troubleshooting

The Troubleshooting Chart contains symptoms which may occur and recommended actions to take if these symptoms do occur.

To help determine which of the above three points are causing the failure keep in mind:

————— **NOTES:** —————

1. In general, check the simplest items first and perform replacements last.
2. Electrical troubleshooting should be performed by a qualified technician as hazardous voltages exist on some components and terminal blocks.
3. A failure can be caused by:
 - a. A control panel PCB.
 - b. An interface box relay.
 - c. The actual hardware component.

- a. If the display responds to the operator controls, then the failure is at either the interface box or the hardware component. If the display does not respond to the controls then check the PCB.
- b. If the display responds to the operator controls and a “click” is heard from the interface box, then the failure is probably at the hardware component (check voltage to component). If no “click” is heard, check for voltage then check the interface box.



When a fuse has failed replace it with one of the same type, size, and rating. If the replacement fuse or a reset circuit breaker fails remove the power immediately from the system by unplugging the power cord and contact a qualified service representative to inspect the system.

Troubleshooting Chart

Symptom	Probable Cause	Recommended Action
<ul style="list-style-type: none"> • Output copy characters gray (Light or gray type) (Positive media only) 	<ul style="list-style-type: none"> • Developer temperature low • Developer replenishment rate too low. • Developer replenishment container empty • Developer replenish pump not operating • Developer circulator pump not operating • Developer nearly exhausted • Phototypesetter; low intensity (lead edge black, characters gray) • Speed control set too fast • Contaminated chemistry 	<ul style="list-style-type: none"> • Check developer temperature • Increase replenishment rate • Check/refill container • Check pump • Check circulator pump • Replace with fresh chemistry • Consult area service office, adjust typesetter exposure control • Slow down transport speed • Change chemistry

<ul style="list-style-type: none"> • Gray background (Positive media only) 	<ul style="list-style-type: none"> • Developer temperature too high • Developer contamination • Fixer replenishment rate set too low • Fixer replenishment container empty • Fixer replenish pump not operating • Fixer circulator pump not operating • Fixer nearly exhausted • Speed control set too low 	<ul style="list-style-type: none"> • Check developer temperature • Dispose of developer; clean developer station • Increase replenishment rate • Check/refill container • Check pump • Check circulator pump • Replace with fresh chemistry • Speed up transport speed
<ul style="list-style-type: none"> • Background has pinkish tint, film or paper 	<ul style="list-style-type: none"> • Fixer nearly exhausted • Fixer temperature • Fixer replenishment container empty • Fixer replenishment rate set too low • Fixer repl. pump not operating • Fixer circulator pump not operating 	<ul style="list-style-type: none"> • Replace with fresh chemistry • Check reset fixer temperature • Check/refill container • Increase replenishment rate • Check pump • Check circulator pump
<ul style="list-style-type: none"> • Yellow stain or off white background (Positive media only) 	<ul style="list-style-type: none"> • Low fixer temperature • Wash water loaded with fixer • Wash recirculator/water supply not on 	<ul style="list-style-type: none"> • Check temperature • Change wash water in recirculator more frequently • Turn on recirculator/water
<ul style="list-style-type: none"> • Processed material has no keeping properties 	<ul style="list-style-type: none"> • Wash water in recirculator dirty or contaminated with fixer • Wash recirculator/water supply not on 	<ul style="list-style-type: none"> • Change wash water more frequently to optimize keeping properties • Turn on recirculator/water
<ul style="list-style-type: none"> • Background turns yellow with age 	<ul style="list-style-type: none"> • Wash recirculator's water exhausted 	<ul style="list-style-type: none"> • Change wash more frequently
<ul style="list-style-type: none"> • No electrical activity 	<ul style="list-style-type: none"> • Main switch tripped • Power plug fell out • Main fuse blown • House circuit breaker • Main switch/circuitry • Power receptacle out of specification • Main board fuse blown • (Vent. blower only operating) 	<ul style="list-style-type: none"> • Place main switch ON • Check power plug receptacle • Check/replace fuse • Check house circuit breaker • Check wiring at switch/replace • Check receptacle and wiring. • Replace fuse
<ul style="list-style-type: none"> • Pumps OK but rollers do not turn 	<ul style="list-style-type: none"> • Rollers will not turn in stand-by • Drive pulley slipping • Drive gears defective • Drive motor wiring circuit open 	<ul style="list-style-type: none"> • Check mode • Check pulley at end of drive shaft and motor • Check/replace gears • Check drive motor wires

SECTION FIVE: Maintenance, Adjustments and Troubleshooting

	<ul style="list-style-type: none"> • Control is in night mode • Speed control interface defective • An error is present (Sad Smiley) 	<ul style="list-style-type: none"> • Put control in standby mode • Check/replace main board • Correct the error
<ul style="list-style-type: none"> • Tank(s) not filling 	<ul style="list-style-type: none"> • Tanks will not fill from container when empty • Replenishment container empty • Repl. pump wiring open circuit • Repl. pump malfunction • Recirculator pump not pumping • Pump assembly defective • A low level condition for more than 70 seconds. 	<ul style="list-style-type: none"> • Fill tanks partly • Ensure container filled • Check pump wires • Check/replace pump • Check relay on relay board • Pump wiring open circuit • Check/replace pump • See tanks not filling
<ul style="list-style-type: none"> • Heater relay led on; developer/fixer not Heating 	<ul style="list-style-type: none"> • Heater wiring disconnected • Heater defective 	<ul style="list-style-type: none"> • Check heater electrical • Check/replace heater
<ul style="list-style-type: none"> • Heater relay not working when the processor is turned on. 	<ul style="list-style-type: none"> • No power at receptacle • Ambient temperature more than set temperature • Chemistry at set temperature • Temperature probe not working • Open circuit • Relay board relay defective 	<ul style="list-style-type: none"> • See no electrical activity • Cool down processor environment • No action/reset temperature • Check/replace probe • Check wires • Check/replace relay board
<ul style="list-style-type: none"> • Material wraps around rollers 	<ul style="list-style-type: none"> • Jumping rollers • Rollers dirty, sticky • Contaminated wash water • Contaminated or weak chemistry • No/poor water flow • Lead edge need fold • Too much silver in fix (> 7 g/l) • No hardener in fix (pH > 5.5.) 	<ul style="list-style-type: none"> • Ensure the transport guides are clicked into place • Clean rollers • Change wash water more frequently • Change chemistry • Check water flow • Fold lead edge • Replace fixer • Add hardener
<ul style="list-style-type: none"> • Foaming 	<ul style="list-style-type: none"> • Replenishment container empty • Developer depleted • Fixer depleted • Air in pump 	<ul style="list-style-type: none"> • Ensure container filled • Change developer • Change fixer • Check hose connections for air leak
<ul style="list-style-type: none"> • Fluid leakage 	<ul style="list-style-type: none"> • Cracked hose connection • Cracked tank connector • Hose leaking 	<ul style="list-style-type: none"> • Repair hose connection • Check/replace tank connector • Check hose and hose clamps,

SECTION FIVE: Maintenance, Adjustments and Troubleshooting

- | | | |
|---|---|--|
| | <ul style="list-style-type: none"> • A bend in drain hose • Tank drain clogged • Drain hose too long | <ul style="list-style-type: none"> replace if necessary • Ensure all drain hoses are straight • Unclog drain • Cut hose to fit |
| <ul style="list-style-type: none"> • Material wraps around dryer rollers | <ul style="list-style-type: none"> • Jumping rollers • Dryer entrance roller are dirty, sticky • Lead edge requires fold • No/poor water flow | <ul style="list-style-type: none"> • Ensure the crossover guides are properly seated • Clean rollers • Fold lead edge • Check water flow |
| <ul style="list-style-type: none"> • Blowers works, but no heat | <ul style="list-style-type: none"> • Loose heater terminal connection • Heater defective • Defective heater relay | <ul style="list-style-type: none"> • Check heater connections • Check/replace heater • Check/replace relay |
| <ul style="list-style-type: none"> • Heater works, but no blower | <ul style="list-style-type: none"> • Loose blower terminal connection • Blower defective | <ul style="list-style-type: none"> • Check blower connections • Check/replace blower |

5.4 Electrical Troubleshooting

(Technicians only)

The processor is equipped with an advanced electronic control system, “CELIS CONTROL” which roughly can be divided into four parts.

A: Relay Board C: Interface Board
B: Main CPU Board D: Control Display

The electronics are designed for multiple use solutions. Therefore a number of features may not be in use on every model. Please see a general description of the different boards below.

A: Relay Board

The relay board handles all the high voltage controls of circulation pumps, replenish pumps, water solenoids, dryer section etc. All relays are mounted on sockets and have a LED to indicate that the relay is active. With jumpers, the relay board can be coded to support external replenish systems for dev, fix and wash.

B: Main CPU Board

The main board is the centre of the Celis Control system. A Phillips CPU 80C552 operates all tasks in the processor. The general programme can be upgraded by either the “boot Eprom” (U8) or by downloading new software via the serial port.

On the main cpu board the connections to analog and digital input are located together with output for film motor, conveyor motors and extra analog outputs. The binary status (0-255) can be displayed in a service menu. (Service technicians only). The main board is connected to the relay board and the interface board.

C: Interface Board

The interface board is connected to the imagesetter. The multi set-up board ensures correct and protected communication to any imagesetter. Read more about setting up this board in the on-line section 8.

D: Control Display

The control display is used to set-up and observe the status of the processor. It is connected

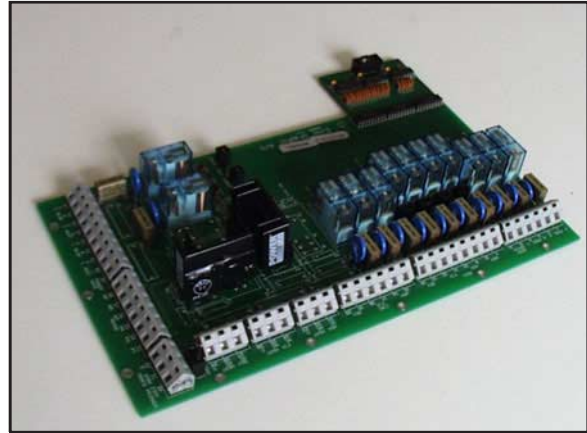

Relay PCB

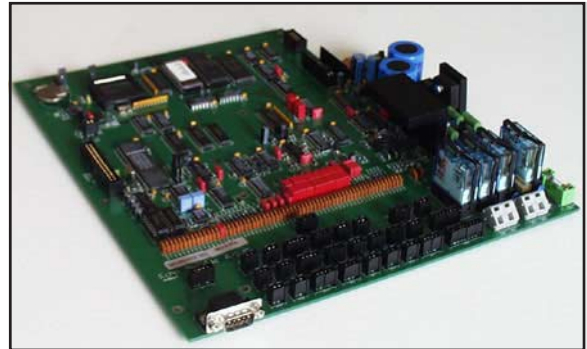

Main CPU board PCB

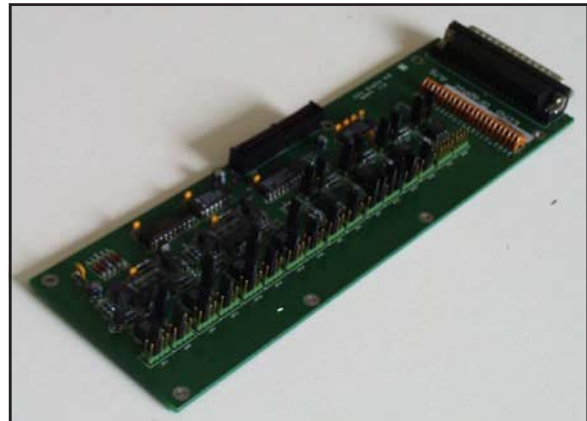

Interface PCB

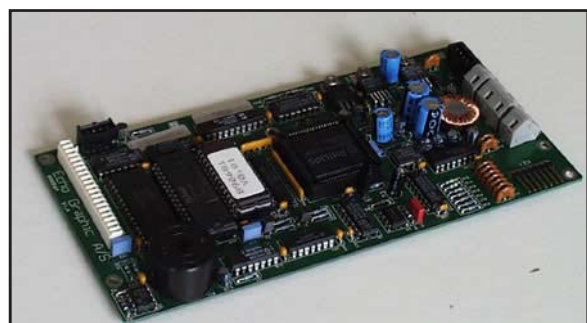

Display PCB

5.5 Printed Circuit Measurements

(Technicians only)

This section describes how to make sure that the electronics are up running. It is intended to help when using the electrical troubleshooting guide. The following measurements are to determine if one or more PCBs are defective. When reading this part please refer to the Interconnection diagram in section 7.

A: Relay Board

1. Make sure that the high voltage power supply 208/230 Volt is on the R-S-T fase pin no. 33 - 38.
2. Verify the voltage on the primary side of the main trafo. pin 32 – pin 33/34 (208/230 Volt).
3. Check the operation of all relays via the service menu. As described in section 5.7

Jumper Settings on the Relay Board

The relay board supports different jumper options for configuring of the output/power supply. For setting locations of the jumpers, please refer to the diagram and location drawing of the relay board in section 7.

- SW1 Bypass of D1 is used when a diode is already build-in the dev. replenish pump.
- SW2 Bypass of D2 is used when a diode is already build-in the fix replenish pump.
- SW3 Bypass of D3 is used when a diode is already build-in the aox replenish pump.
- SW4 Bypass of D7 is used when a diode is already build-in the wash replenish pump.
- SW5 – SW8 Used for disconnection of RC out filter. Must be cut when an external replenish or mixer system is used.
- SW9 Used to configure 208V or 230V

Input - Output from Relay Board

For output to pumps, dryer sections, heat elements please refer to the relay diagram and the interconnection diagram. in section 7.

B: Main Board

To make sure that the main board is running please follow the guidelines below. Before measuring refer to diagram 40800 and the location drawing in section 7 when controlling the operation of the main board.

1. Make sure that the voltage power supplies, from the main trafo is min 22 volt AC. It can be controlled on pin 62 – 63.
2. Check fuse F1 (4A) for main power supply.
2. Check fuse F4 (4A) for AC power supply to conveyor motors.
3. Check fuse F5 (4A)/(6,3 on Combi) for film motor
4. Check the test points:
 - TP1 5 Volt DC
 - TP2 15 Volt DC
 - TP3 6,5 Volt DC
 - TP4 12 Volt DC
5. Check the power supply to the panel (P1) on pin 1, 24 volt DC and pin4, VoltDC

Jumper Settings on the Main Board

The main board has a number of different jumpers, which are used to control the start sequence and various sensors. For location of the jumpers please refer to the diagram and location drawing. in section 7.

- SW1 Watchdog, default mounted
- SW2 Ultra-sonic or mechanical film switch sensor input is selected, mechanical is default.
- SW3 Ultra-sonic or mechanical film switch sensor input is selected, mechanical is default.

SECTION 5

- SW4 Fixed conveyor 1, motor speed /power limit DC, default Not mounted.
- SW5 Fixed conveyor 2, motor speed /power limit DC, default Not mounted.
- SW6 Batt. backup, default mounted.

C: Interface Board

Please refer to the on-line section 8 for setting up this board.

D: Control Display

To make sure that the display is working please check the connection cable for errors. After checking the cable check the following points:

1. Check that the power supply is present. 24 volt DC can be measured from JP6 to JP4 (Gnd) on the display board.
2. Check the test points:
 - TP1 24 Volt DC
 - TP2 12 Volt DC
 - TP3 5 Volt DC
 - TP4 -15 Volt DC

Jumper Settings on the Display Board

- SW1 Watchdog, default mounted.

5.6 Repair instructions

 Do not try to repair a PCB. The PCB will be out of warranty if unauthorised soldering or exchanged of components are made. For correct repair return the complete PCB to your dealer. Relay PCBs, interface PCBs, main board and display boards can be repaired. Remember to state the serial number of the processor.

5.7 Accessing the configuration Utility

Access to the Service Menu

Switch the processor off and on and press **S** when the processor is in stand-by mode.

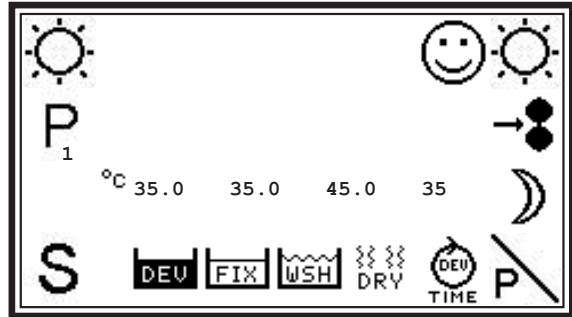

Stand-by mode

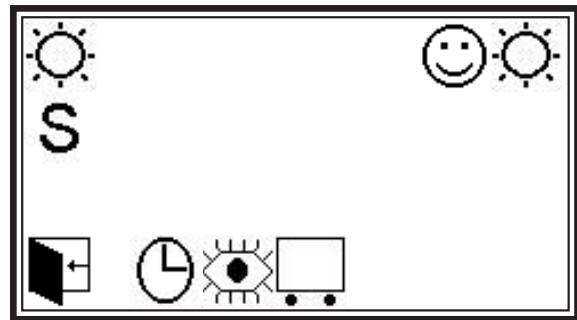

When the setup menu appears press the three right buttons in the following order: Top, Middle, Bottom.

This service menu will appear.:

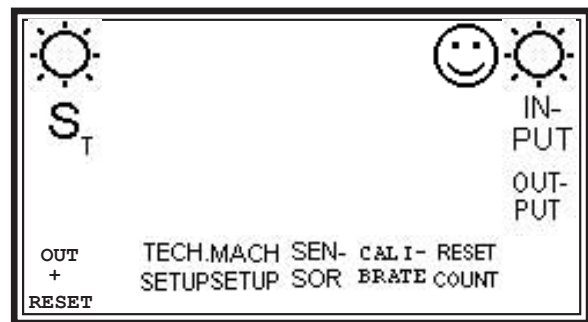

Service menu

5.8 Service menu structure

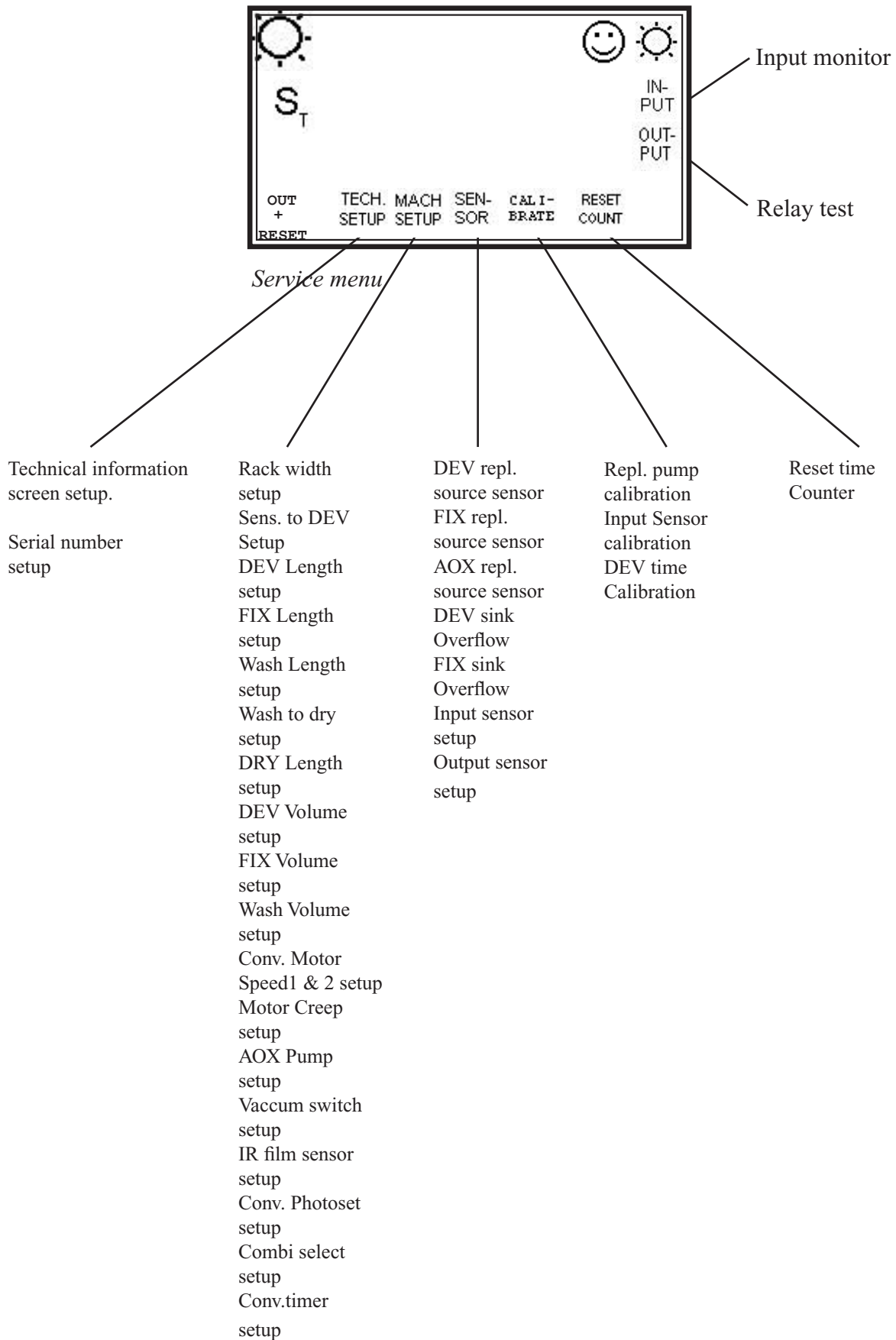

5.9 Relay test

To access the output “test” press **OUT-PUT** and the menu for testing outputs will appear.

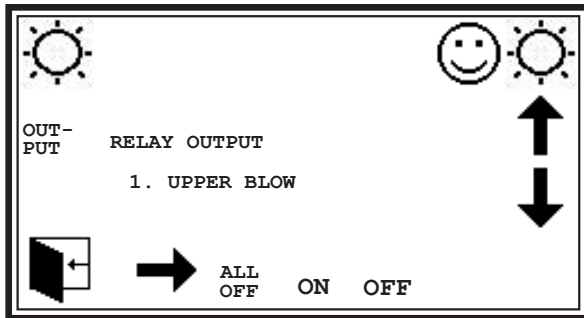

Output status menu

Use **ON** and **OFF** to test the relay. The arrows **↑** and **↓** are used to select relay or fixed conveyor motor. The **→** arrow shifts to the conveyor test mode. The OLB test and setup are described in the on-line section 8.

 When using the relay test option it is possible to bypass the low level alert. Heat elements in dev, fix and wash must not heat when dry. Make sure that the processor has chemistry and water.

 When testing the relay both the LED and a measuring can be used to ensure the function.

5.10 Testing of sensor inputs

The software supports a read-out of all inputs with of binary value (0-255). This means that a defective sensor can be tested for variations. For example if the developer temp. is 35 °C / 95 °F the binary value is 160. To select this option open the service menu and choose the input part **IN-PUT**. Find the read-out below.

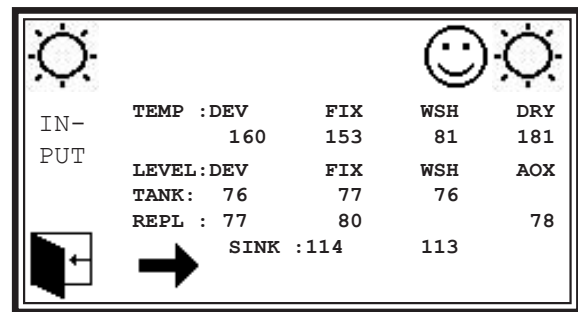

Input status Temp / Level

Push the **→** arrow to shift to sensor status. (Inlet IR / Mek/US, Vacum etc.)

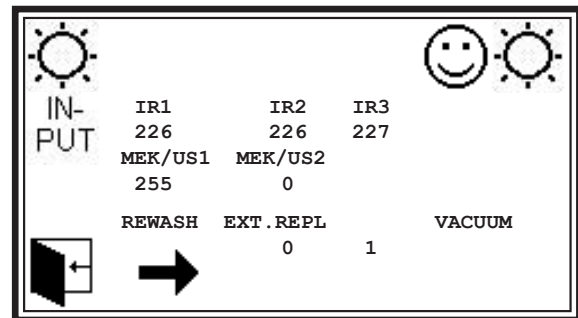

Input status IR / MEK

Pushing the **→** arrow twice will bring up the status for imagesetter communications

 If the temp. / Mek- sensor cable is disconnected the binary value will be close to 255. (The max. value for the temperature ex. 50 °C are displayed). If the temp. / Mek-sensor cable has a short-cut the binary value will be close to 0. (the min. value ex. 5 °C will be displayed). If the IR sensor are disconnected the binary value will be 0. If the IR sensor has a short-cut the binary value will be close to 255.

5.11 Technical information setup

To enter the technical setup. Press ^{TECH.} _{SETUP} from the service menu

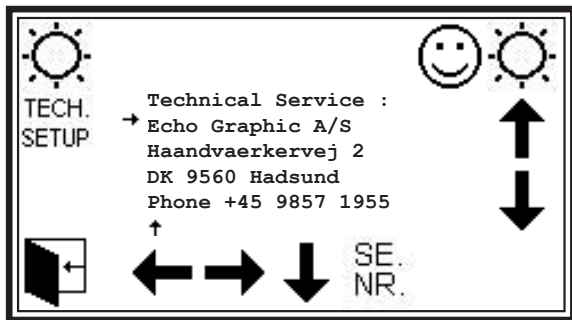

In this menu it is possible to change the technical information screen. This information should be changed at installation to show the name of the supplier or service company who installed the machine. Use the arrowkeys to change the characters.

Setup of serialnumber ,by pressing the key ^{SE.} _{NR.}

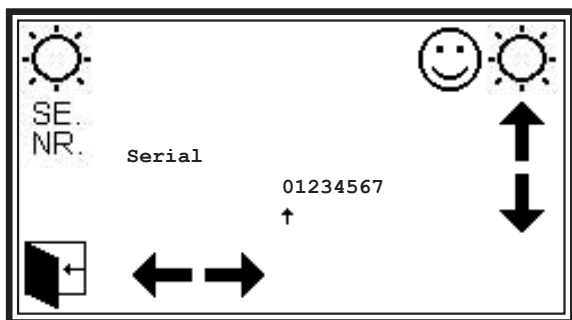

Serialnumber setup

Here the serial number can be changed. The correct serialnumber will normally be programmed from the factory.

5.12 Mechanical machine setup

To enter the mechanical machine setup press the key ^{MACH} _{SETUP}

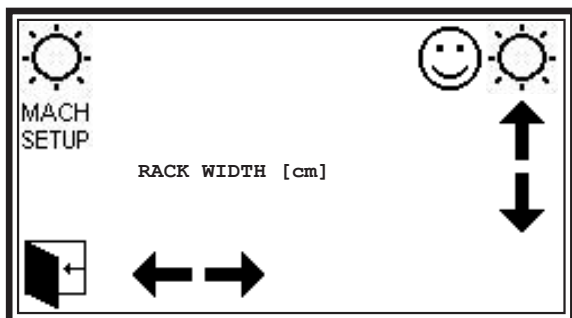

Mechanical setup menu

This menu is used to tell the controlunit all the details about the hardware which is connected to it.

Below find a list of the menu options.

To step through the different option, use the left and right arrow keys. To change any value use the up and down keys.

RACK WIDTH [cm]

Specifies the width of the racks mounted in the machine.

SENS TO DEV [cm]

Specifies the distance from the inlet sensor to the inlet roller in the dev rack.

DEV LENGTH [cm]

Specifies the length of the developer rack

FIX LENGTH [cm]

As above

WSH LENGTH [cm]

As above

WSH TO DRY [cm]

Specifies the length from the wash rack to the dryer rack (**Only used in Combi processors**)

DRY LENGTH [cm]

Specifies the length of the dryer rack.

DEV VOLUME [L]

Specifies the size of the developer tank, in liters.

FIX VOLUME [L]

As above.

WSH VOLUME [L]

As above.

CONV. MOTOR SPEED 1 &2 (25-255)

Specifies the speed of the conveyor motor (if connected)

AOX PUMP

Enables or Disables external AOX pump.

MOTOR CREEP

Enables or Disables the motor creep option. (Creep enabled will cause the rollers to turn slowly in standby mode.)

VACUUM SWITCH NO or NC

Specifies the type of vacuumswitch. Normally open or Normally closed. (If no sensor is connected NC should be selected)

IR FILM SENSOR

Selects type of inlet film sensors.

IR or REED NC or NO.

PROCESSOR TYPE

Selects Film, Polyester plate, Combi prim, Combi sec. processor.

CONVEYOR/PHOTOSET

Selects type of online.

COMBI SELECT

Selects if the control unit is a single system. Or a primary or secondary in a combi processor.

CONV. TIMER 1

Through

CONV. TIMER 6

These parameters specifies the online bridge timing for the different online options.

Detailed information can be found in the online section 8. To exit press 

5.13 Sensor configuration setup

To enter this menu press the key 

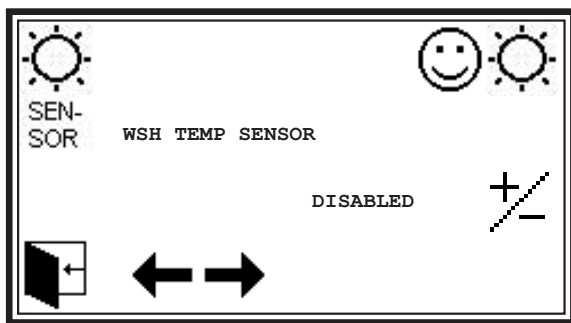

Sensor setup menu

Step through the menu options with the arrow keys. To toggle settings press +/- button.

WSH TEMP SENSOR.

Enables or Disables the water temperature control.

LEVEL SENSOR

DEV REPL. SOURCE

Enables or Disables the low level sensor in the dev. repl. container.

FIX REPL. SOURCE

As above.

AOX REPL. SOURCE

As above.

DEV SINK OVERFLOW

Enables or Disables the high level sensor in the dev. overflow container.

FIX SINK OVERFLOW

As above

INPUT SENSOR

FILM INPUT IR : 3

Selects channels to use for sensor input.

1, 2 or 3 IR sensors, Mechanical/Ultrasonic. Or receive signal from Primary control.

Shift between mechanical and ultrasonic is done by jumper 2 on the main board. Refer to **Jumper settings on the Mainboard page 5-53.**

OUTPUT SENSOR

FILM OUTPUT 1 MEK/US

Enables or Disables output sensor. Refers to Mech sens2 channel on the motherboard.

Shift between mechanical and ultrasonic is done by jumper 3 on the main board. Refer to **Jumper settings on the main board page 5-50.**

5.14 Calibration menu

To enter this menu press the key 

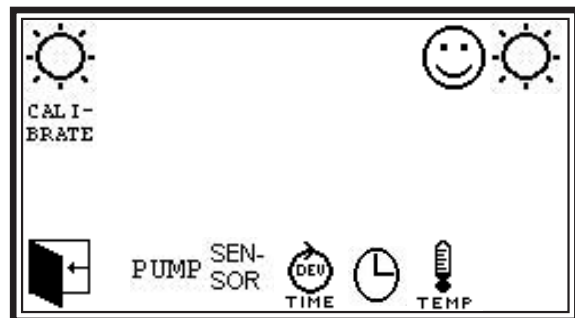

Calibration menu

Pump calibration menu

To enter this menu press the key **PUMP**

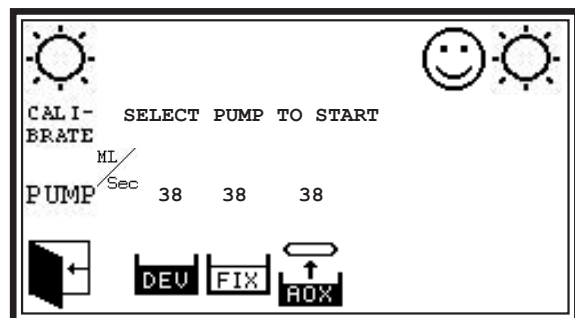

Pump calibration menu

In this menu it is possible to calibrate the three possible pumps. When pressing one of the three buttons, the chosen pump will be activated for a fixed time period. When the pump has stopped the machine will ask for the volume supplied. (Use a measuring bucket) It tries to supply 800ml.

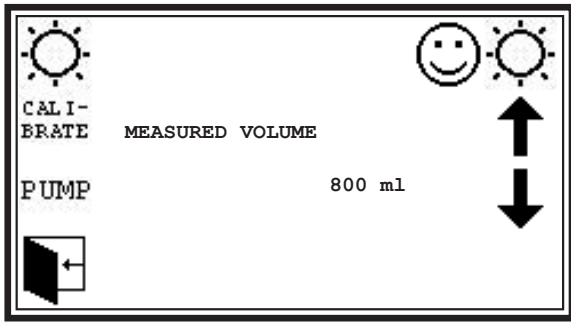

Now check the volume supplied in the bucket and change the value with the arrow keys. To exit press the  key, and proceed with the next pump if wanted. (It may be necessary to

Sensor calibration menu

To enter this menu press the key 

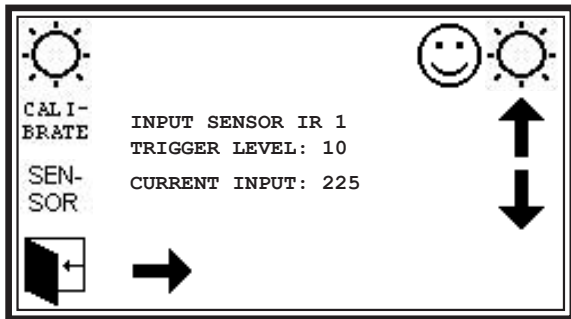

Sensor calibration menu

In this menu the trigger levels for the different input and output sensors can be setup. Use arrow keys to change values. Right arrow key to select sensor.

Dev time Calibration

To enter this menu press the key 

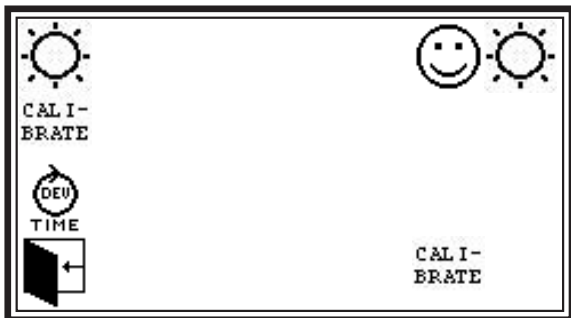

Motor calibration menu

Before starting the motor calibration, make sure that the rack lengths have been setup correctly, as explained previous in this chapter.

Press the  button. Now the machine will start the drive motor and a show a flashing message: CAL: INITIALIZING, shortly after

the motor will stop and a new flashing message will be displayed: CAL: INSERT FILM Now insert exactly one meter of film into the inlet of the processor. Introduce the film fast into the first set of rollers. The motor will start again and CAL: IN PROCESS will be flashing.

When the film has left the input sensor the speed will be calibrated. The motor will run until the film has left the processor.

Clock calibration menu

Temp sensor calibration menu

Reset time counter menu

To enter this menu press the key 

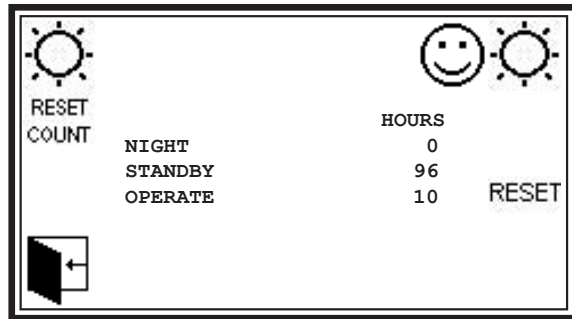

Reset time counter menu

In this menu the time counter can be reset. Pressing the  key will reset all the counters to 0.

Exiting the configuration utility

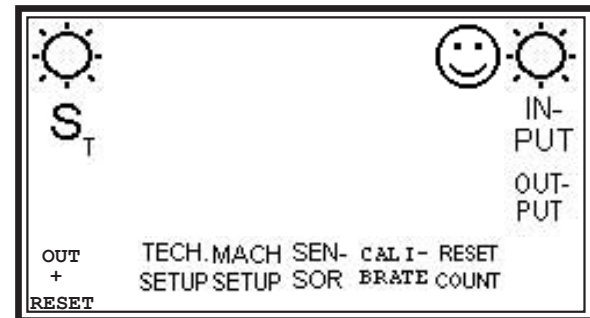

Service menu

Press the  button.

The machine will now perform a reset, and return to standby mode.

5.15 Updating the software in the Celis Control

To install the Celis software update program please follow these instructions:

1. Copy the file D:\Software\celis.zip to the directory where the Celis program shall be installed.

Ex. C:\echo\celis.zip

2. Extract the file “Celis.zip” to the same directory.
3. Run the installation file from the location.

Ex. C:\echo\disks\setup.exe.

4. Select installation directory.
5. Press “Finish” to install the program.

6. Reboot the computer.
7. The installation program creates a short-cut in the start menu. Press the Celis icon to start the program and follow the instructions in the program
8. Select COM port.
(default com1)
9. Connect the 0-modem serial cable to the Celis Control.
10. Start the update of software and settings.

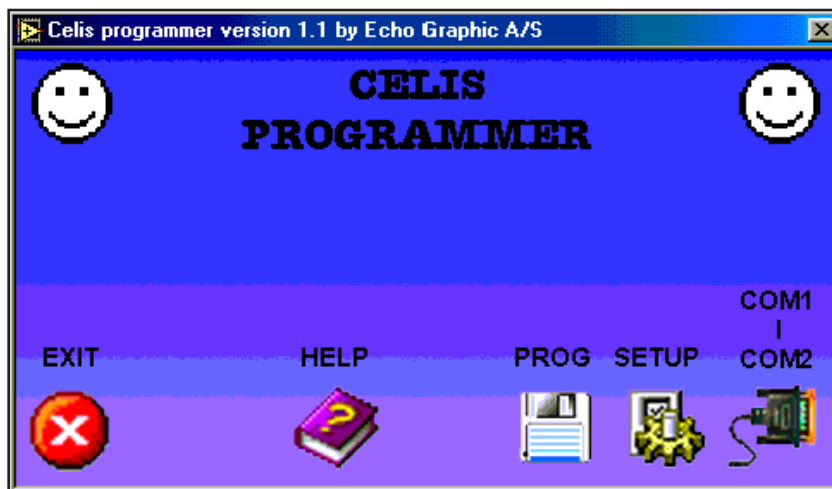
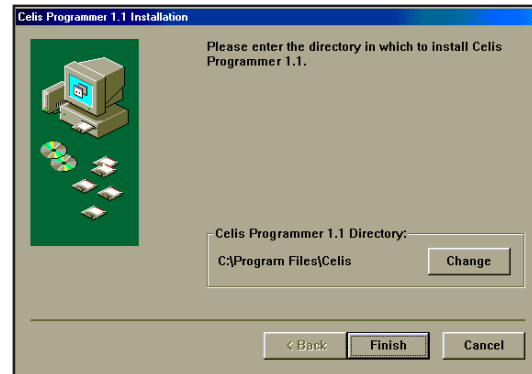

To make it easier to use the program you can copy the Celis software folder ex. v1_27 and v2_10 to the same directory where you installed the program. The latest version can always be found at our homepage: www.echographic.dk/service

5.16 Updating the Software in the Celis Control

The software in the Celis Control is stored in a flash memory on the main CPU board and on the display board. **Note: The software for the two boards is not the same!**

Tools needed to perform the update:

- * Celis programming software
- * Romfile for main cpu board
- * Romfile for display board
- * PC or Laptop with a communication port COM 1-4
- * Windows 95/98 2000 NT operating system
- * Standard .0 modem cable. Can be ordered at Echo Graphic part nr. 365088.

Connect the PC COM to the connector P1 on the main CPU board with the cable. Now turn off/on the Celis Control. The display should look like this.

All software can be downloaded from Echo Graphic's service homepage www.echographic.dk or be supplied on a disk.

Press the Prog icon on the Celis Programmer and select the rom file to update and press ENTER.

The PC will now compare the file version with the board version and ask if you wish to proceed with the update. Press Y for Yes or N for No.



The update process will last several minutes.

Proceed with the next rom file if desired. After completing both Main and Panel quit the Flashbrn.exe program. The Celis Control will now start up using the new software.

If main changes are made the setup.txt (equal to the product number) should also be updated in the same way.



If you update the setup file the processor should be calibrated. See page 55 and 56 in the manual for calibration of pumps, dev. time and in some instances sensors.

Reboot the processor and your Hope/Carnfeldt processor will start to use the new software. Please refer to release notes on each software version regarding special parameters.

WAITING FOR MAIN

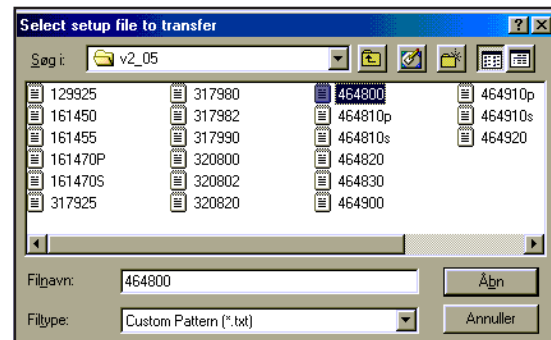
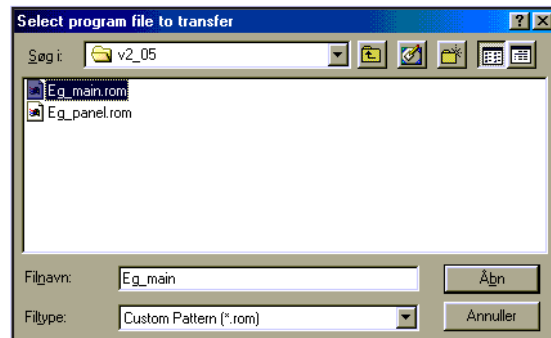

6.1 General

This section details the general and specific tasks which are to be performed by a trained service engineer for removal and replacement of the processor's components.

Before starting any procedure read the WARNINGS listed below.



WARNINGS:

- a. Turn off the main switch and lock by a padlock before starting a procedure.
- b. Never allow loose clothing or jewelry to come close to the gear train, media transport area, an electrical connection, or any terminal block.
- c. Before starting any procedure that involves working on one of the fluid circulating stations, always drain the system thoroughly.

6.2 Removal/Replacement Procedures

Below is an alphabetical list of all the Removal/Replacement Procedures outlined in this section:

PROCEDURE DESCRIPTION

Chemistry Heating Elements
 PCBs
 Drive Motor
 Dryer Fans
 Dryer Heating Elements
 Fuses
 Gearwheel
 Interface box
 Low Level Sensors
 Pumps
 Rollers, Gears, Bearings, and Transport Sensor
 Temperature Probe
 Water Valve



Fig 6-A

6.2.a Chemistry Heating Elements Removal/Replacement Procedure

Equipment Required
 Small screwdriver
 Open end wrench
 Tubular wrench # 19

1. Turn the main power switch OFF and lock by a padlock.
2. Drain the chemistry.
3. Remove roller rack in the relevant tank.
4. Remove the cover on the right side of the machine.
5. Disconnect the wires from the heating elements by the two 4 MG nuts.
6. Remove the two 14 MG nuts holding the heating element in the tank. Use a pair of pliers to hold the element on the inner side.
 Clean the surfaces around the holes in the tank and mount the new element with new gaskets inside the tank. Tighten the 14 MG nuts while holding counter inside the tank.
7. Replace the wires into the terminals and tighten the screws (fig. 6-A). See task 5.
8. Place the cover on the right side again by its 4 screws.

6.2.b PCBs Removal/Replacement Procedure

Equipment Common screwdriver
required:

1. Turn the main power switch OFF and lock by a padlock. The power cord can be left connected if an electronic adjustment is being performed.
2. Remove the two screws on the front of the interface box (fig. 6-B).



Fig. 6-B. Remove the 2 screws shown.



Fig. 6-C. view of Main and Relay board..



To prevent damage to the PCBs always turn the processor off and wait 15 sec. before pulling out or plugging PCBs or connectors.

3. The PCBs can now be replaced.
4. Place the front and mount the two screws removed in task 2.

6.2.c Drive Motor and Gearwheel in Dry Gear Train Removal/Replacement Procedure

Equipment 7 mm wrench
 Required Common screwdriver
 A pair of pliers
 Side cutting pliers

1. Turn the main power switch OFF and lock by a padlock.
2. Remove the side panel on the left side of the dryer section.
3. Remove the 4 screws holding the plastic cover and remove the cover.
4. Remove the cotter pin holding the gearwheel to the motor axle and remove the gearwheel.
5. Remove the necessary gearwheels to obtain access to the 3 countersunk screws holding the motor.
6. Unscrew the 3 countersunk screws holding the motor, keep track of the spacers and washers behind the plate between motor and plate.
7. Note the wire locations and disconnect the two electrical connections.

REPLACEMENT MOTOR INSTALLATION

8. Reconnect the two electrical connections to the replacement motor.
9. Place the motor into its mounting bolts. Remember the distance tubes.
10. Place the motor gearwheel onto the motor shaft and mount a new cotter pin.
11. Reassemble the cover to the gear train.

one framed model

Fig. 6-D

two frames model

Fig. 6-E

Gear train and drive motor position in processor.

Fig. 6-F
Drive motor

6.2.d Dryer Fans Removal/Replacement Procedure (Horizontal Dryer)

Equipment Common screwdriver
Required Small common screwdriver

1. Turn the main power switch OFF and lock by a padlock.
2. Get access to both sides of the involved EG blower by lifting off the upper EG blower or removing the dryer rack with the EG blower.
3. Remove the 6 screws holding the blower to the chassis.
4. Note the wire positions and unscrew the three blower wires from the terminal block, disconnect the yellow/green ground wire.
5. Remove and replace the blower, make sure to install the new blower with correct flow direction.
6. Remount the 4 screws.
7. Mount the three wires in the correct position of the terminal block. Remove the paint where the yellow/green ground wire is mounted and secure the wire with its screw.
8. Reinstall dryer rack and blower channel.



Fig. 6-G

6.2.e Dryer Heating Elements Removal/Replacement Procedure (Horizontal)

Equipment Common screwdriver
Required Small common screwdriver

1. Turn the main power switch OFF and lock by a padlock.
2. Get access to both sides of the involved EG blower by lifting off the upper EG blower or removing the dryer rack with the blower.
3. Remove the 4 screws holding the heating element.
4. Note the wire positions and disconnect the two / three wires from the heating element and unscrew the yellow/green ground wire.
5. Replace it with the new heating element.
6. Reconnect the wires and the yellow/green ground wire.
7. Reinstall dryer rack and blower.

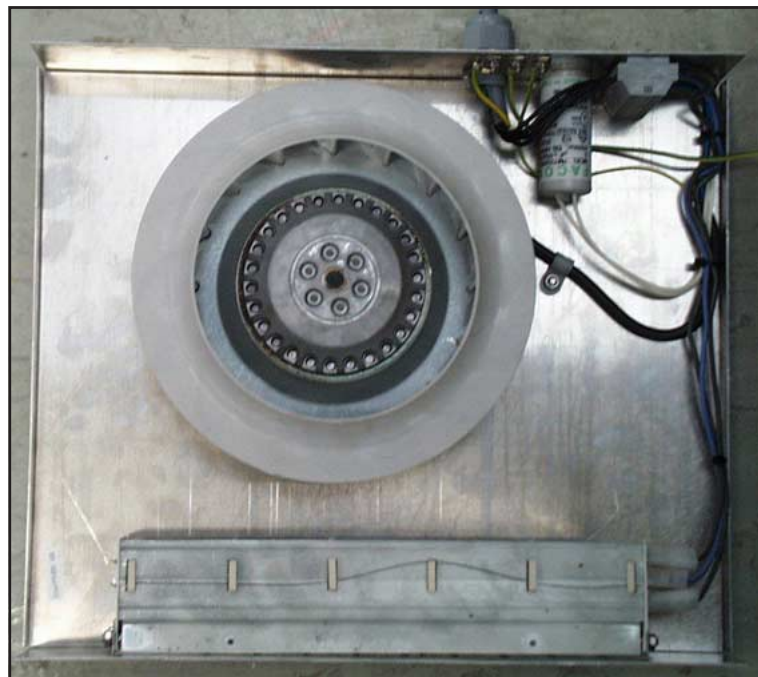

Fig. 6-H

6.2.f Fuse Removal/Replacement Procedure

The processor has a total of three fuses:

- 1) 4-pole main circuit breaker
- 2) Main power fuse - Internal
- 3) Conv. motor fuse - Internal

1. Turn the main power switch OFF and lock by a padlock.
 - The interface box is situated above the receiving basket.
 - Remove the interface box cover and replace the blown fuse.
 - Mount the interface box cover again.



When a fuse has failed, replace it with one of the same type, size and rating. If the replacement fuse fails remove the power immediately from the system by turning off the main switch and contact a qualified service representative to inspect the system.



Fig 6-I Low voltage fuses Main power and Conv. motor fuse

6.2.h Pump Removal/Replacement Procedure

Equipment required
 7 mm box screwdriver
 (wrench)
 Common screwdriver
 Pliers
 Screw clamp for squeezing
 hose

1. Turn the main power switch OFF and lock by a padlock.
2. Drain the tank associated with the pump to be replaced. The chemistry remaining in the tubes and the pump housing may be removed by carefully blowing compressed air into the suction studs in the tank. Be careful not to blow too hard - or chemistry drops will splash all over. Instead of draining the tank both tubes to the pump may be closed by squeezing the tubes with a screw clamp 20 cm from the pump - in this case be ready to collect chemistry draining out when the tubes are removed from the pump.
3. Remove the hose clamps from the tubes on the pump and remove the tubes, be ready to collect chemistry draining out from the tubes.
4. Disconnect the electrical wires.
5. Remove the 4 pc 4MG set screws holding the pump.
6. Reinstallation goes in reverse order.

One Frame model

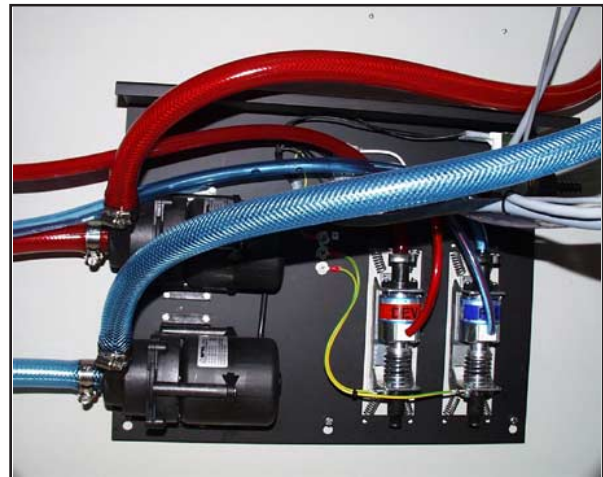

Fig. 6-J

Two Frame model



Fig. 6-K

6.2.k Rollers, Gears, Bearings and Transport Guides Removal/Replacement Procedure

Equipment required: Common screwdriver
Side cutting pliers
Pliers

1. Turn the main power switch OFF and lock by a padlock.
2. Lift the rack to be repaired out of the processor and place it in a tray or a sink.



It is recommended to flush developer and fixer racks with water before any major work to protect against skin irritation and tools from rusting.

3. Removing Main Rack Gearwheels
The main gearwheels are retained on the studs on the rack side with a plastic lock washer, which can be lifted off with a screwdriver or a small pair of pliers. The number and position of distance washers should carefully be noted. When the gearwheel is reinstalled it is recommended to use a new lock washer.
4. Removing Rollers
The stainless steel lock washers on each end should be cut off with side cutting pliers. In the dryer rack nylon lock washers are used. Now with most of the rollers they can be pushed to the end with the D-axle, and the other end can be lifted out from the rack.
5. With a few of the rollers which have two long axles, it is necessary to remove one of the axles from the rollers to remove

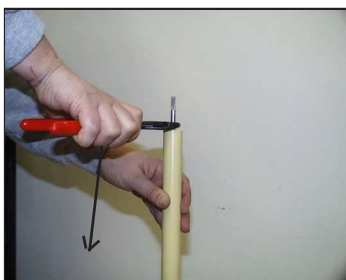

the rollers.

6. The axles can be pulled out from the roller by gripping the axles with a side cutting pliers, resting the jaws against the end of the roller. Now the axle can be worked out. Take care not to damage the part of the axle running in the bearing.
7. The bearings are pushed into the rack sides and can only be exchanged when the rollers have been removed. When a rack is being serviced all bearings with more than one mm play should be replaced.
8. The axles are tapped into the end of the rollers with a hammer, normally so far that the knurling just disappears. The axial play of the gearwheels on the roller should be closely examined. It may be necessary to tap some of the axles further in to secure correct mesh of gearwheels and prevent collision.
9. When the rollers are remounted be careful to install the correct washers, pulleys and springs, if any. Lock the gears with new lock washers.
10. Turn the rack by hand and make sure that it turns smoothly and easily with no jumps.

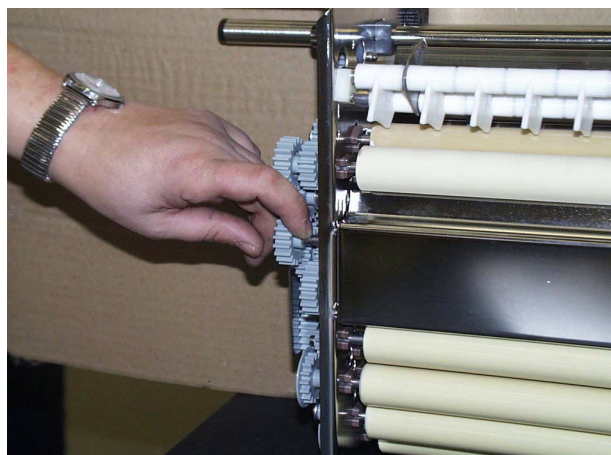

Fig. 6-L

6.2.j Feed Sensor Removal/Replacement Procedure

Equipment Required	Common screwdriver Small screwdriver Side cutting pliers Cable straps
--------------------	--

1. Turn the main power switch OFF and lock by a padlock.
2. Remove the top cover.
3. Disconnect the cable from the sensor.
4. Exchange now the sensors.
- 5 Plug the cable into the new sensor,. Remember the small tube must be around the connection.



Fig. 6-M

6.2.k Temperature Probe Removal/Replacement Procedure

Equipment Required	Common screwdriver Small screwdriver # 13 open end wrench
--------------------	---

1. Turn the main power switch OFF and lock by a padlock.
2. Remove the 4 (four) screws holding the cover over the interface box. (Fig. 6-N).
4. Unplug the sensor plug (JP 2, 3, 5 or 7) from the mother board.
5. Dismount the side cover on the right, the plastic cover and the small covers holding the temp. sensor
6. Remove the old sensor cable.
7. Reinstallation goes in reverse order.



Fig. 6-N

Remove screws

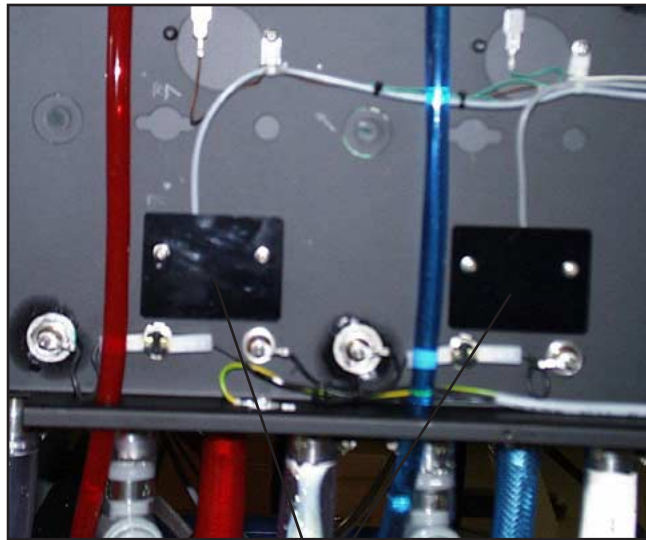

Fig. 6-O

Temp. sensor cover

6.2.n Water Valve Removal/Replacement Procedure

Equipment required:	Common screwdriver Adjustable wrench Small pipe wrench Universal pliers
---------------------	--

1. Turn the main power switch OFF and lock by a padlock.
2. Turn off the water supply and disconnect the water supply hose from the solenoid valve.
3. Unscrew the housing for the solenoid valve from the pump support under the wash tank.
4. Pull off the electrical connections from the solenoid valve, disconnect the hose from the solenoid valve inside the processor and remove the two 4 MG screws that holds

the solenoid valve.

5. Mount the new valve its position by its two 4 MG screws and push on the electrical connection.
6. Reinstall the two hoses.
The hose clamp on the internal tube must

One Frame model

Fig. 6-P

Two Frames model

Fig. 6-Q

6.3 Sensors in EG models

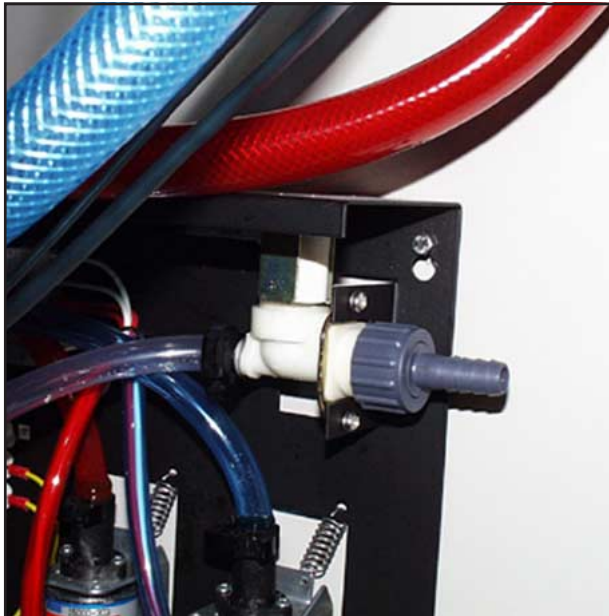

6095 Micro Switch Reed Angled Arm.

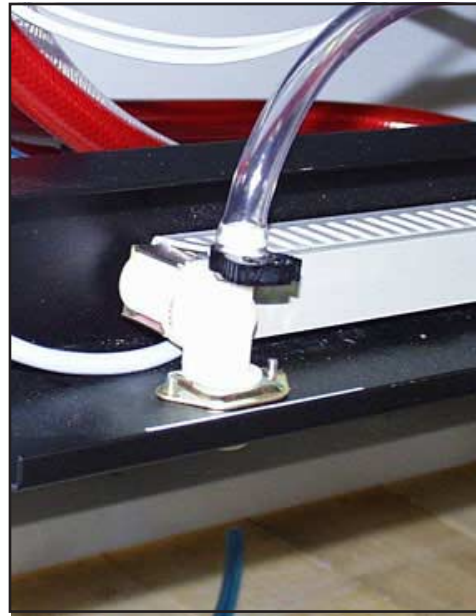
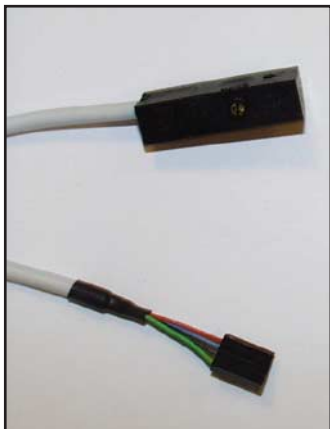

320298 Feed Sensor,IR 260cm EG/cel
320299 Feed Sensor,IR 330cm EG/cel



305119 Temp.Probe NI1000 210cm+plug'



305036 Level Sensor 69 mm EG Fix, Wash and EP Act
305136 Level Sensor 56 mm EP Stab. and Wash.
305236 Level Sensor 83 mm EG Dev.

6.4 Complete Roller Overview

Roller Types	Part number				
	29"	36"	45"	54"	65"
5/8" PU Roller	129534	136533			
5/8" Steel Roller		136544		155536	
13/16" Soft Rubber EPDM	129064	136374	330034	155027	
25mm Aluminium Roller				155474	650504
25mm Steel Roller Solid					650044
25,2mm Soft Rubber EPDM	129074	136484	330044	155084	
25,4mm ALUstar	129275	136275	330275		
1" PU Roller		61131			
1" PU Roller smoot	129013	136163	330003	155023	
1" Roller PU rough	129003		330012	54454	
1" PVC Roller	129223				
1" Soft Rubber EPDM	129054	136354	330354	155355	650234
31,5mm Hard Rubber		136294	330294	155294	650293
1 1/4" steel Roller				155007	650253
1 1/4" Hard Rubber				155227	
1 1/4" Soft Rubber Roller	129283	136284	330284	155284	650284
1 7/8" PU Roller smoot	129453	136453	330453	155453	650453
1 7/8" Foam Roller				54130	
1 7/8" Soft Rubber Roller EPDM	129273	136274	330274	155274	650274
1 7/8" Steel Roller					650243

6.5 Axle Overview

Type	Name	Part number
D	Axle D	276044
O	Axle- O >	276034
LO	Axle- O >1/4" x 47.8 Long	235184
D1	Axle-D, Long F.1 Gear Wheel	276074
D2	Axle-D, Long F.2 Gear Wheel	276084
	Axle-D 1/4 IN,Long F.1.G.W.	235234
1/4"	Starlock	117337

On location drawings the letter reference only refers to type. **NOT** how long the axle is. Please check the sequence number in the part list when ordering for a specific roller.

6.6 Complete Gearwheel View

Number of Teeth	Type of Gearwheel	Drawing Shaft Identification	Diameter	Part NO:
10	D-Center Lock	A	1/4" D	217524
13	D-Center Lock	B	1/4" D	217484
16	D-Center Lock	M	1/4" D	217374
16	O-Center Lock	L	1/4" O	217364
16	D-Center Lock		1/4" D	217504
18	D-Center Lock	E	1/4" D	217474
18	O-Center Lock	Y	1/4" O	217354
20				276037
24	O-Center Lock	G1	10,2mm	276154
24	O-Center Lock	G	14,2mm (*)	217534
24	O-Center Lock	N	1/2" O	65268
24	O-Center Lock	N1	1/2" O, 17mm wide type	68011
25	O-Center Lock		10mm (*)	66689
30	O-Center Lock	P1	10,2mm (*)	54266
30	D-Center Lock	P	1/4" D	217414
30	O-Center Lock	O	1/4" O	217344
32	O-Center Lock	X	10mm	217434
32	O-Center Lock		10,2mm	65993
32	O-Center Lock	X	10,2mm	275155
32	Hexagon		Hexagon	217394
34	O-Center Lock	A1	10mm	54268
35	O-Center Lock	Q	10mm (*)	66248
36	O-Center Lock	R	10,2mm	217424
36	O-Center Lock	S	10mm (*)	65502
36	O-Center Lock		Hexagon	217384
37	O-Center Lock	W	10mm (*)	66263
40	O-Center Lock	B1	10mm	65981
42	O-Center Lock	J	10,2mm	217464
48	O-Center Lock	K	10,2mm	233454
48	Hexagon		Hexagon	217347
79	O-Center Lock	V	10mm (*)	63186
79	Hexagon	H	Hexagon	65960
80	O-Center Lock	U	10mm (*)	65456
80	Hexagon		Hexagon	65959
80	O-Center Lock	T	10,2mm	65139
80	O-Center Lock		F. Microswitch	60210
80			Special	276017

(*) With hole for Cotter Pin

SECTION SIX: Removal/Replacement Procedures

Number Type of Teeth	Drawing of Gearwheel	Shaft Identification	Part NO: Diameter	
16+18	O-Center Lock	D	16,2mm Dual Gear	233434
16+18	O-Center Lock	D1	10mm Dual Gear	68807
36+24	Gearwheel for Rewinder		Special	250064
48+32	O-Center Lock	C	10,2mm	276104
48+36	O-Center Lock	F	10,2mm	276114
32+36	Hexagon	SX	Hexagon	68216

Steel Gearwheels:

25	O-Center Lock		15mm	65888
32	Hexagon		Hexagon	117528
34	D-Center Lock		15mm	270517
36	O-Center Lock		Hexagon	117518
60	O-Center Lock		15mm	65218
62	O-Center Lock		15mm	65707

NOTE

All partnumber are always printed on the gearwheel it self.

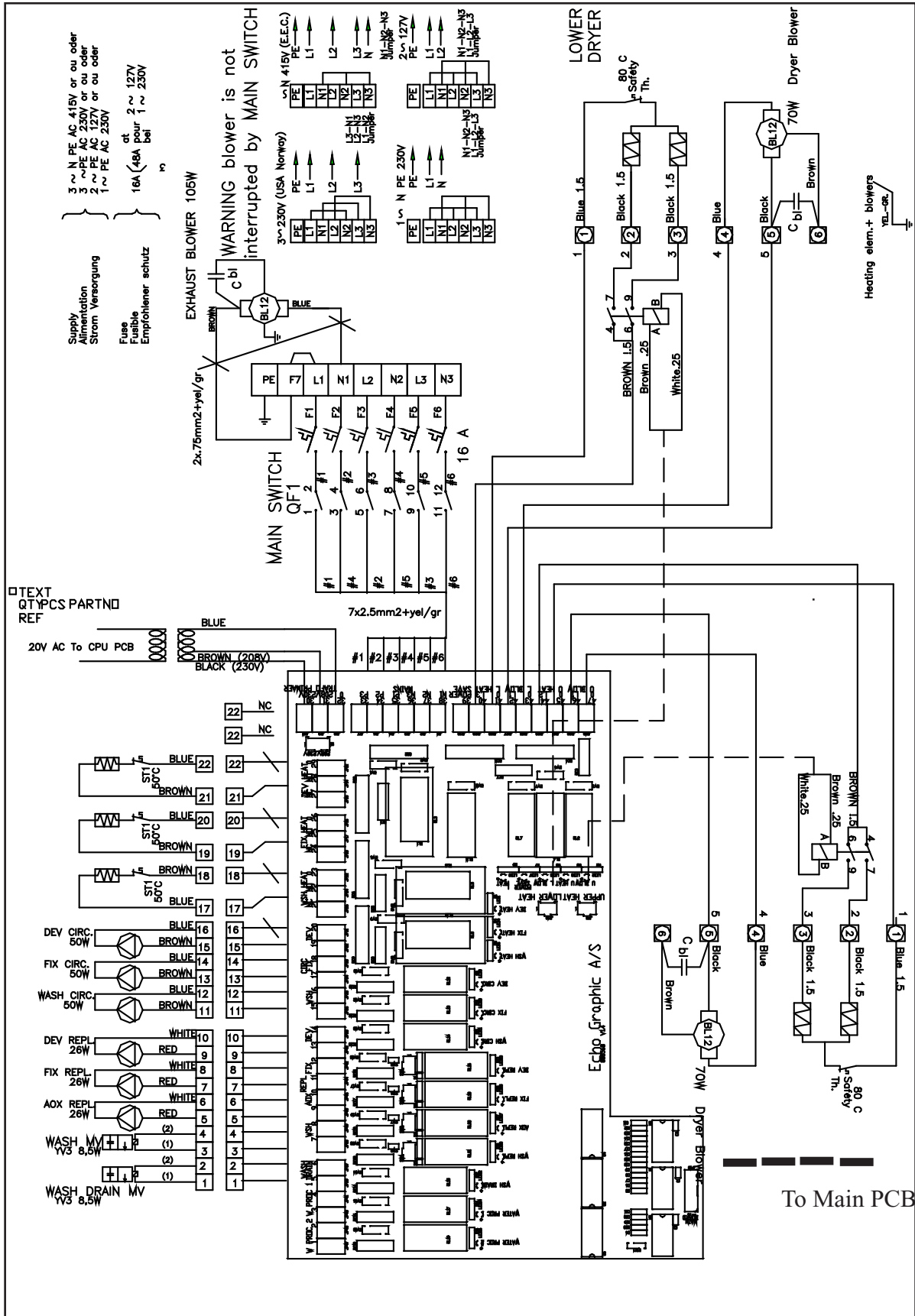

SECTION 7

Interconnection diagram for two section processors, drawing 6324a

SECTION SEVEN: Electronic and Mechanical Diagrams

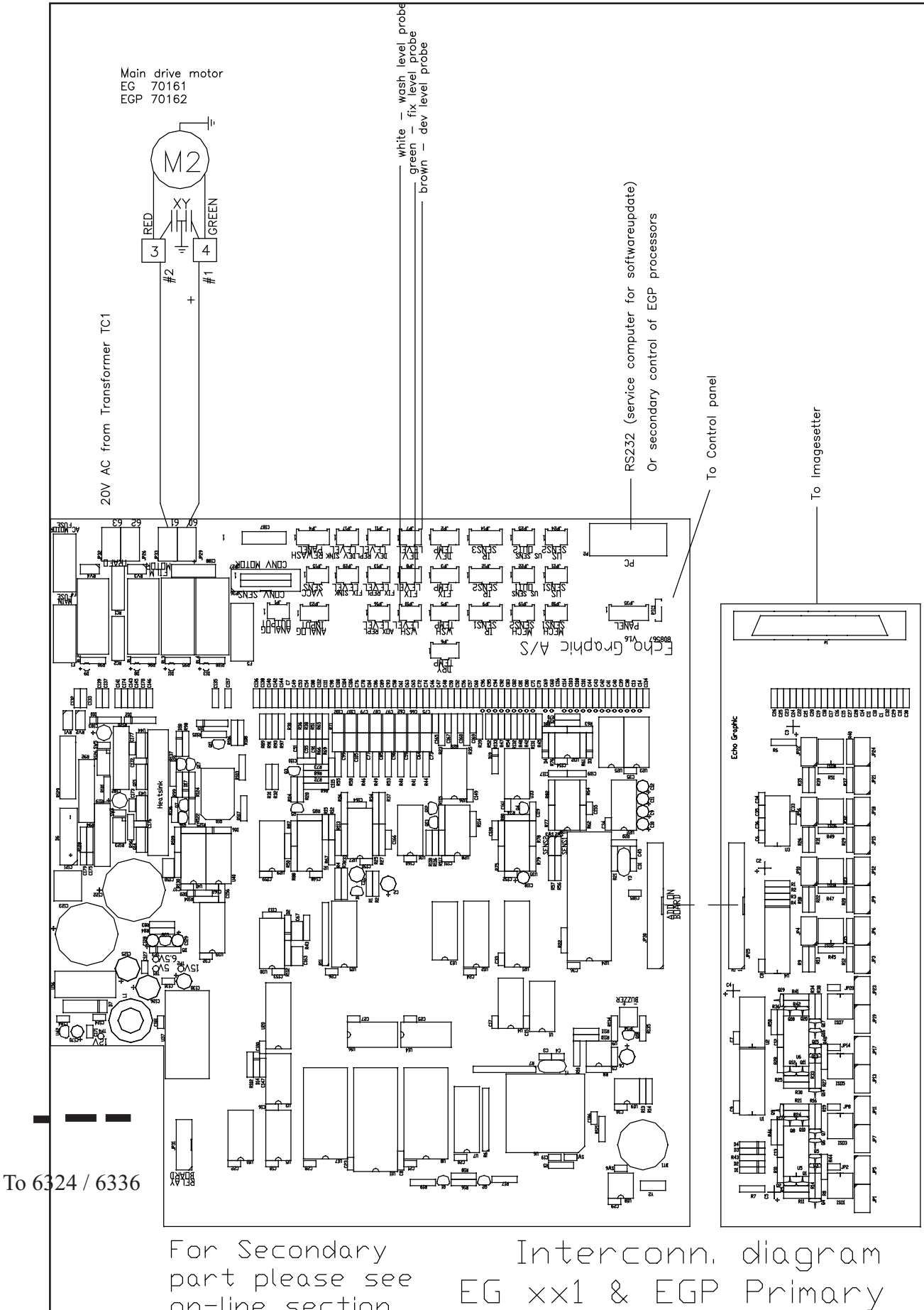

SECTION 7

Interconnection diagram, drawing 6324 and 6336

SECTION SEVEN: Electronic and Mechanical Diagrams

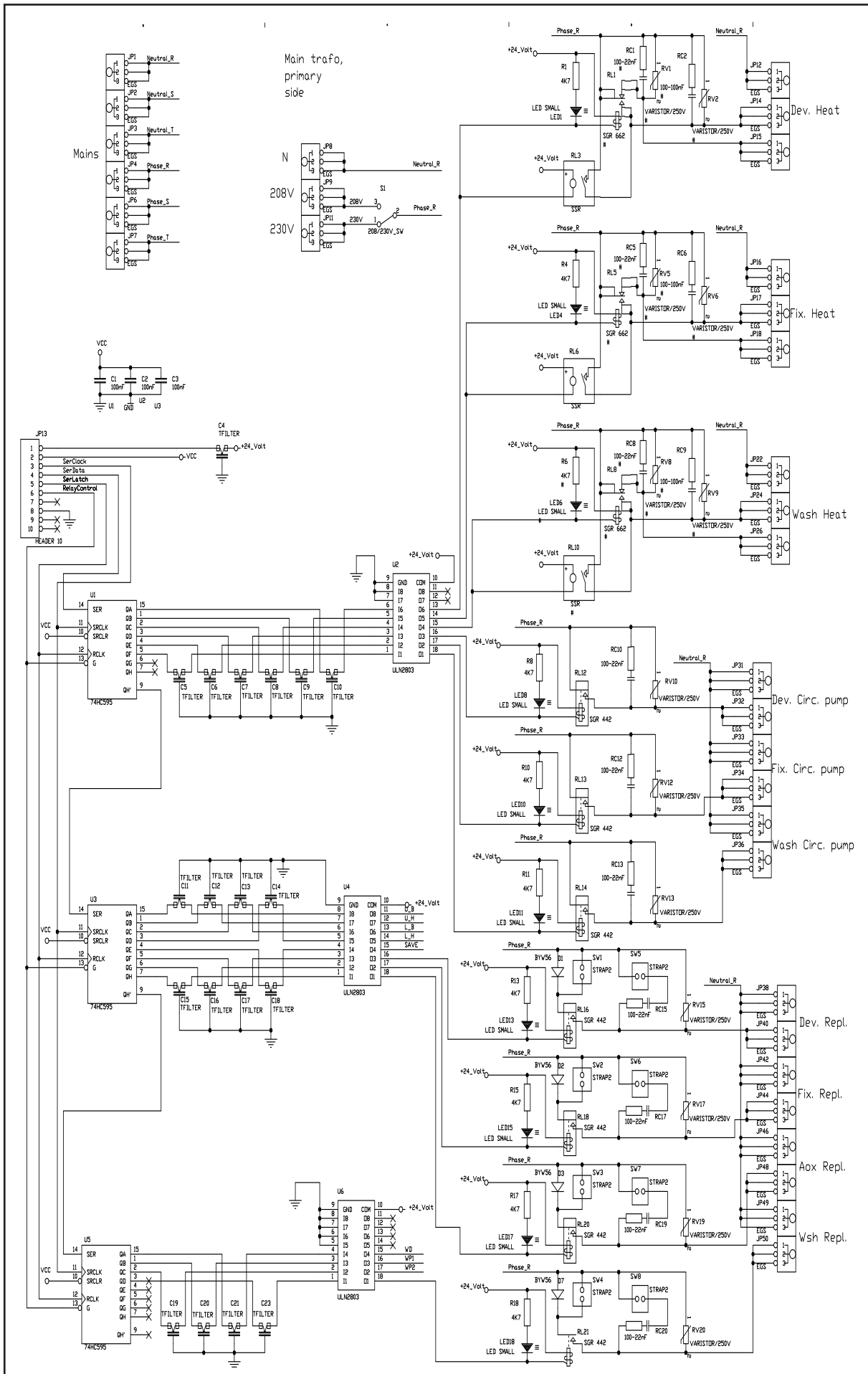

SECTION 7

Relay Board Drawing 4080101a

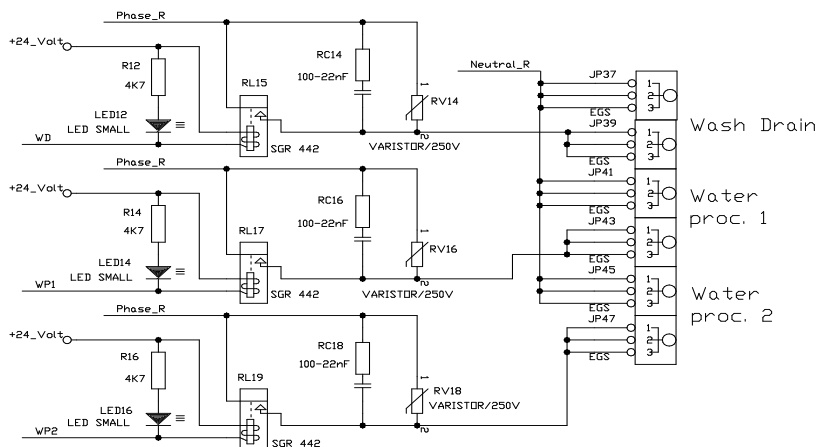
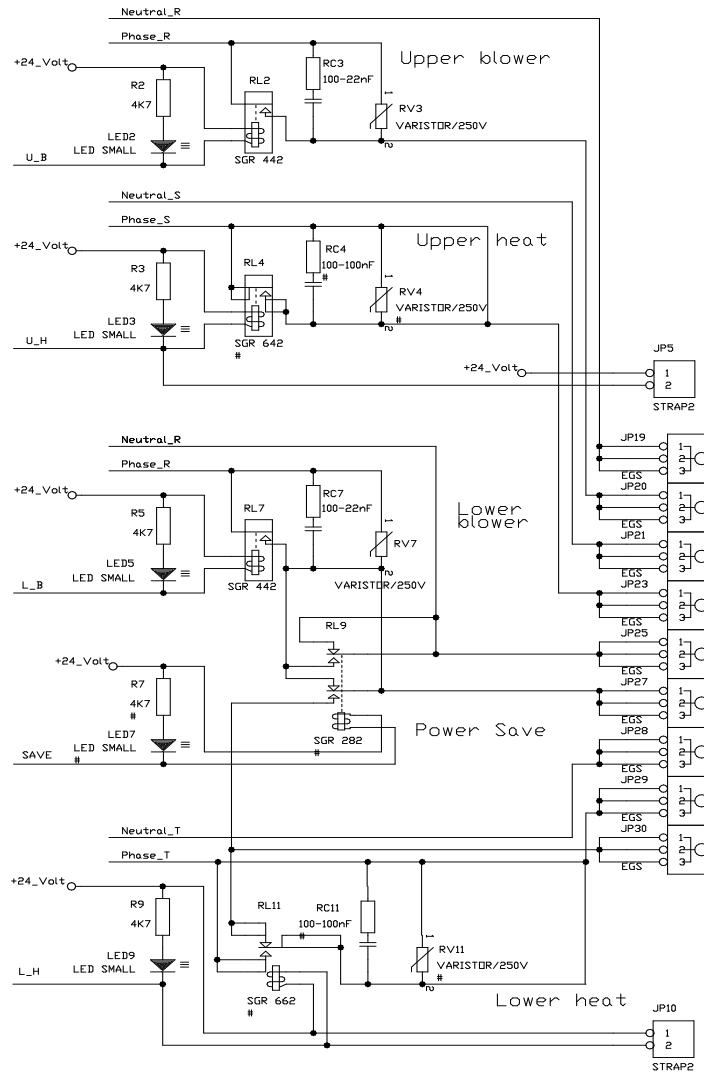

#-Optional

SECTION SEVEN: Electronic and Mechanical Diagrams

SECTION 7

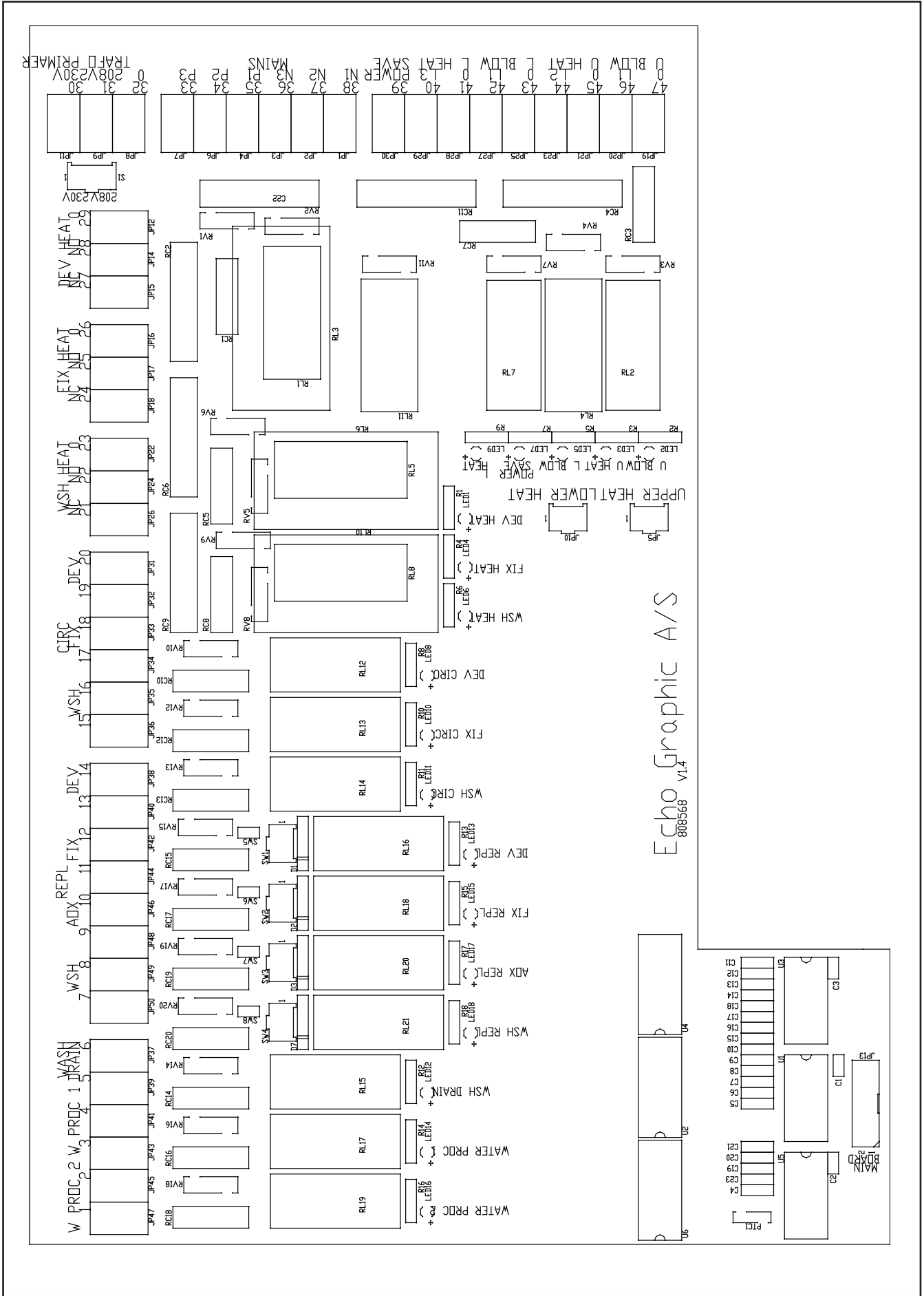

Relay Board Location Drawing 4080101

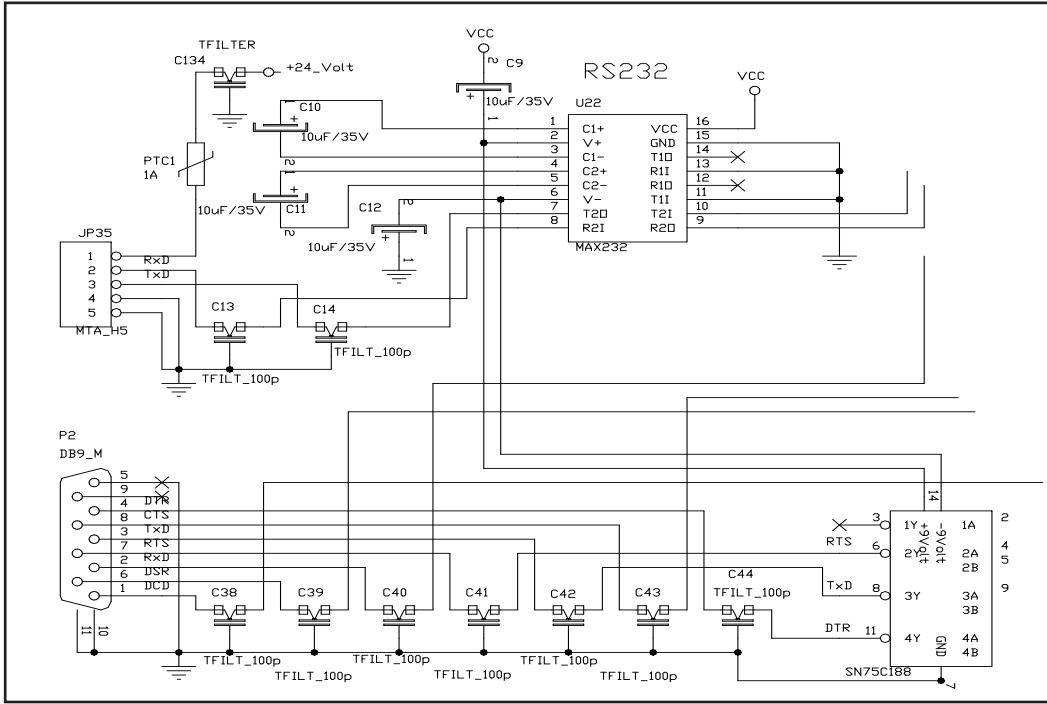

Main Board Communication Drawing 4080100a

DEV Level

FIX Level

WASH Level

DEV Repl

Fix Repl

AOX Repl

DEV Sink

FIX Sink

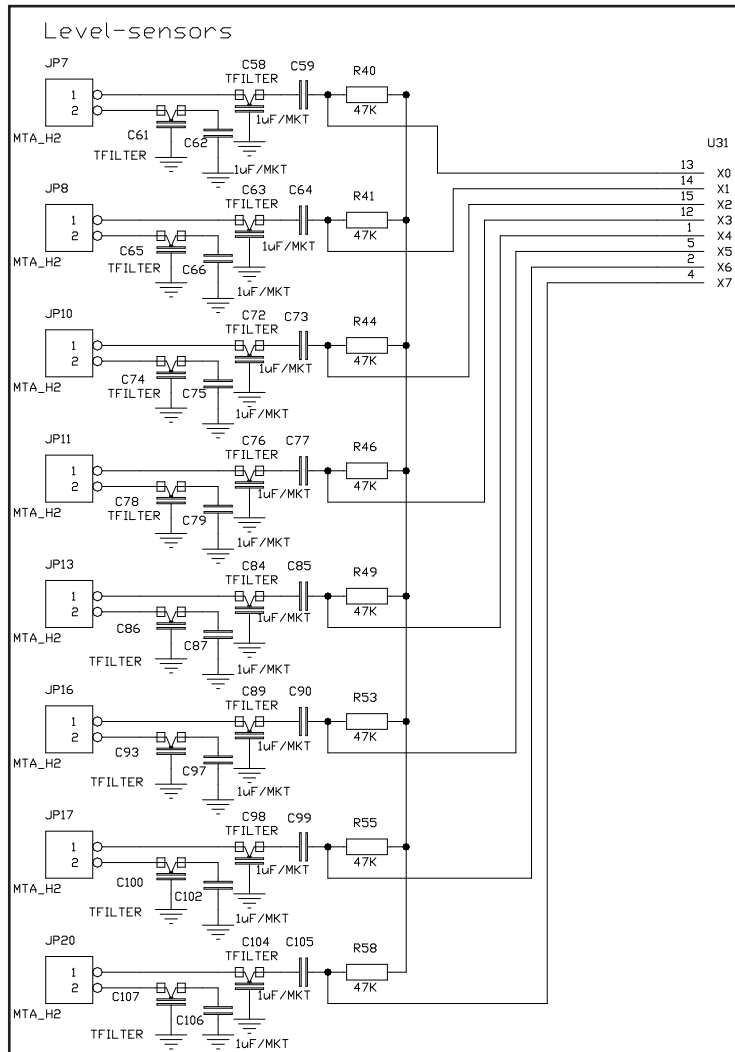

Level sensor input Drawing 408000b

SECTION SEVEN: Electronic and Mechanical Diagrams

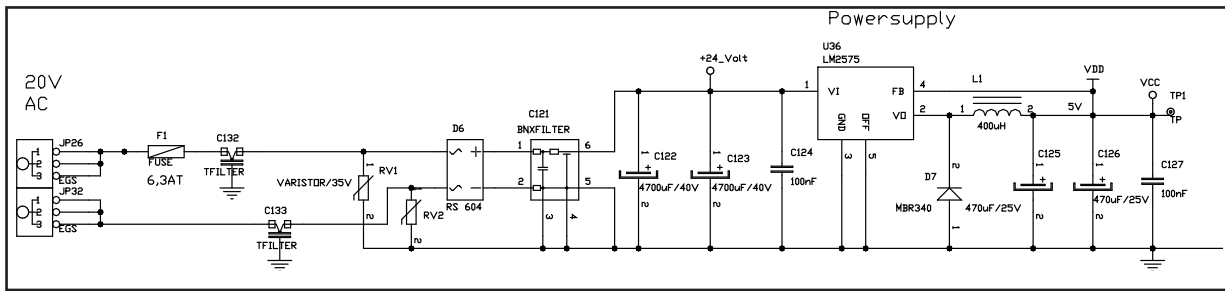

Main Board Power supply Drawing 40800c

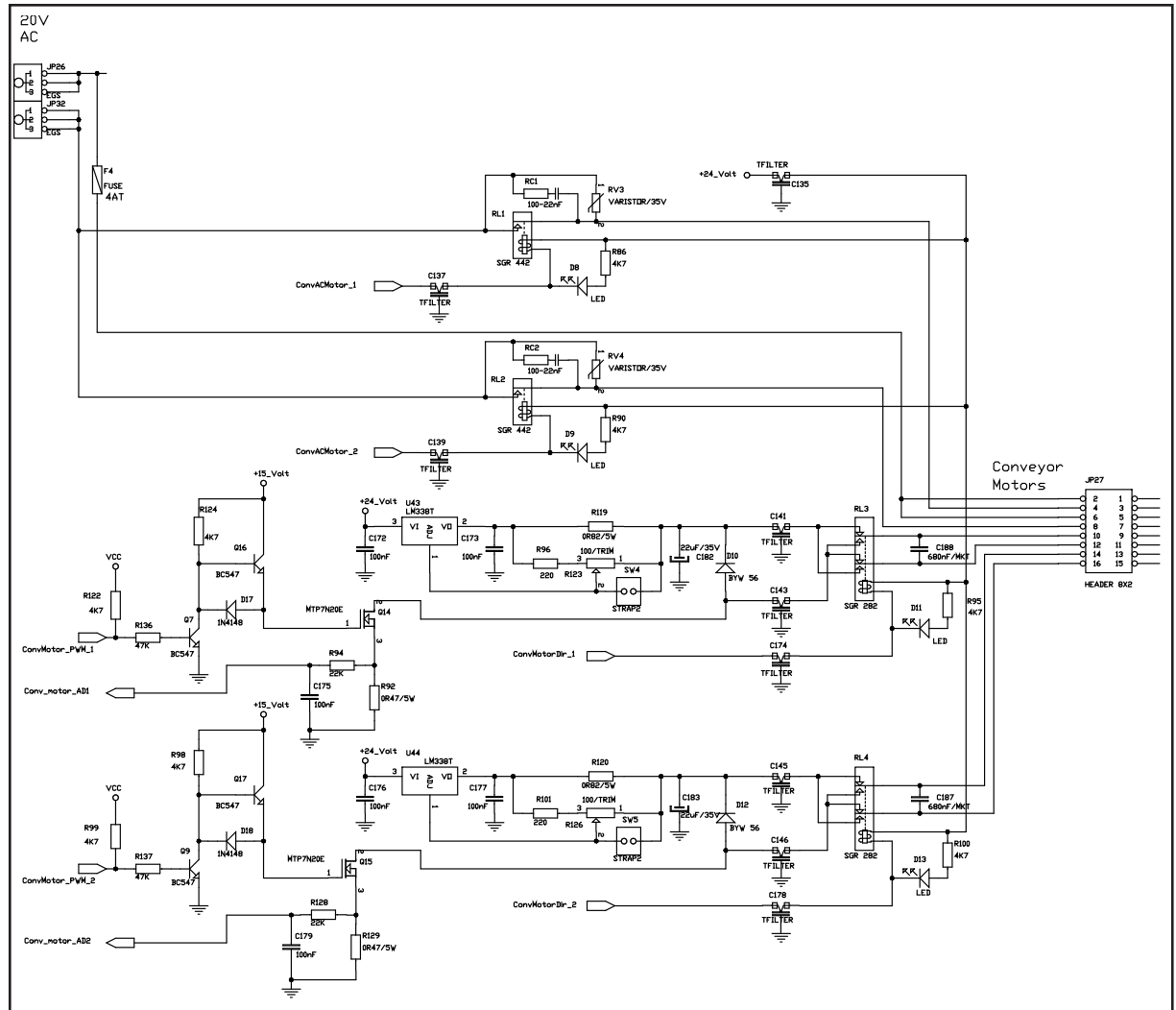

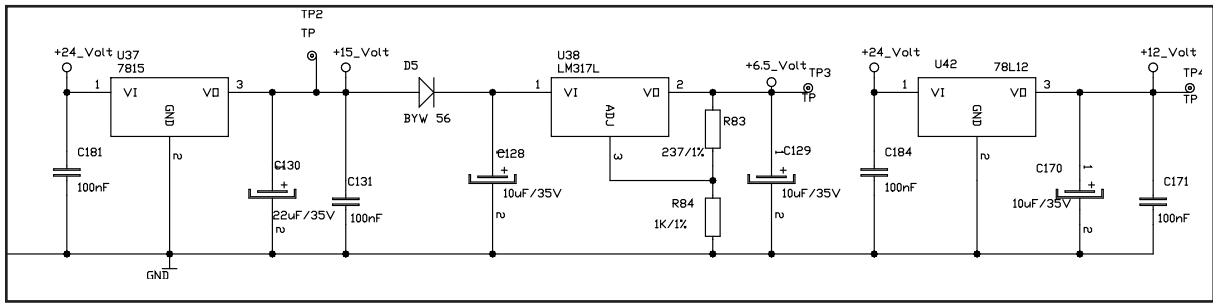

Main Board Power supply Drawing 40800c

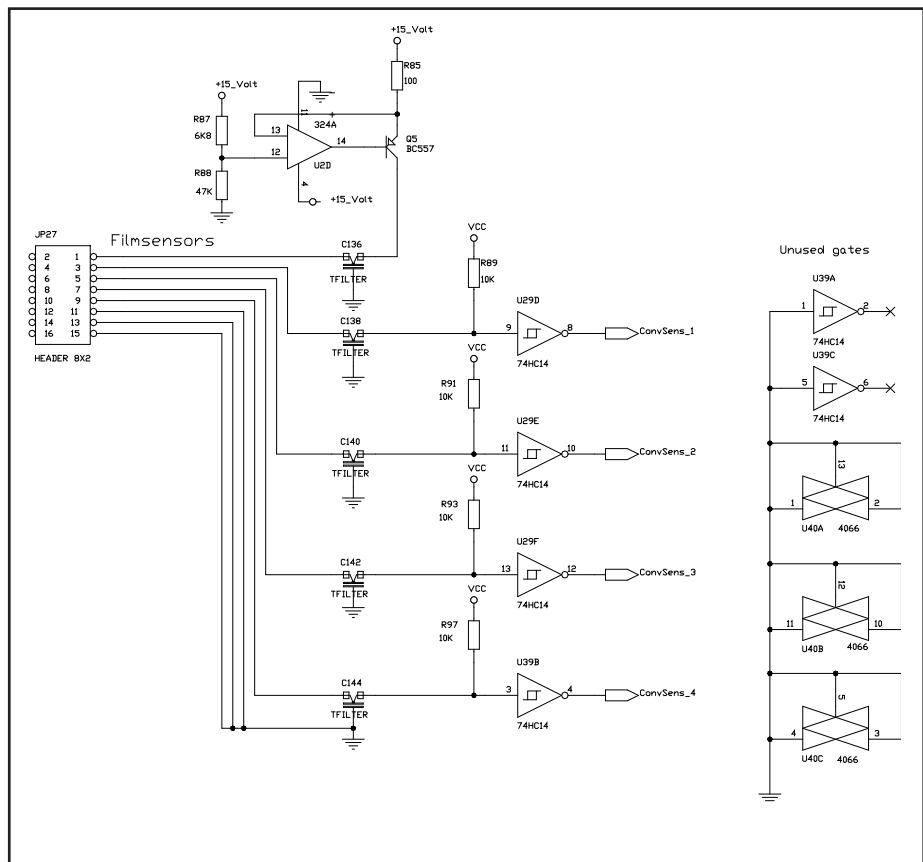

Main Board Conveyor sensor Drawing 40800e

DEV
FIX
WASH
DRY

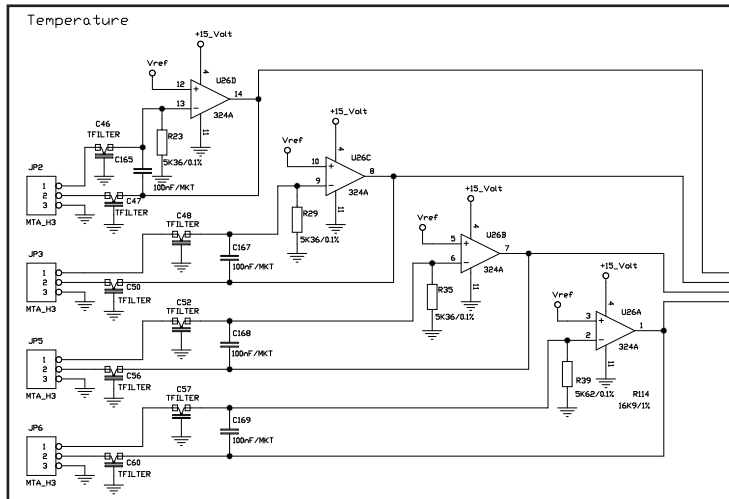

Main Board Temperature Drawing 40800g

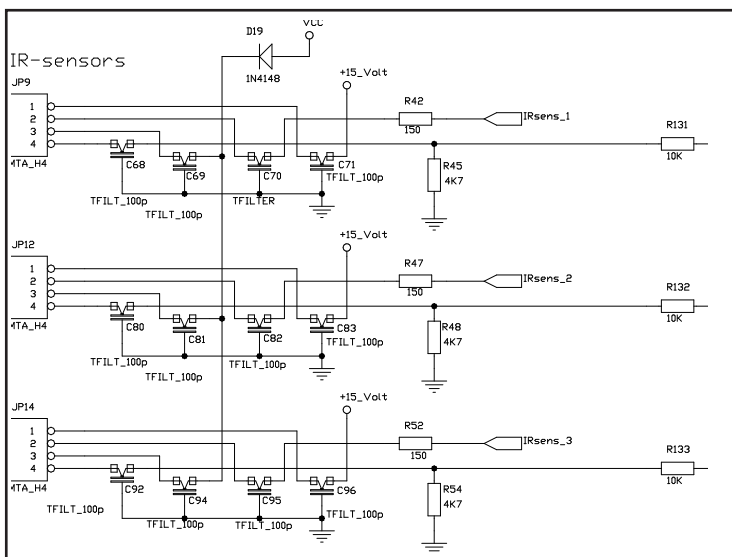

Main Board IR-sensors. Drawing 40800h

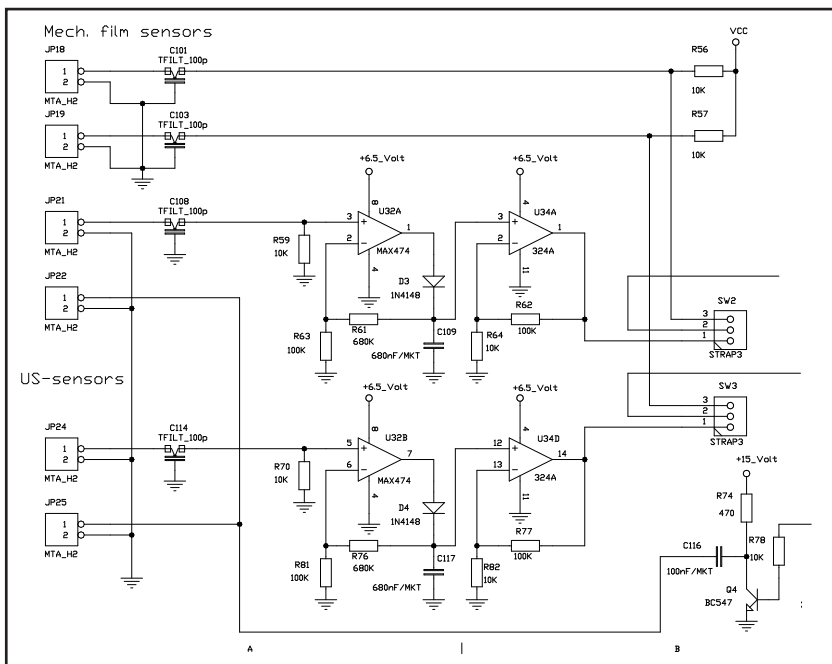

Main Board Mechanical & US-sensors. Drawing 40800i

SECTION 7

SECTION SEVEN: Electronic and Mechanical Diagrams

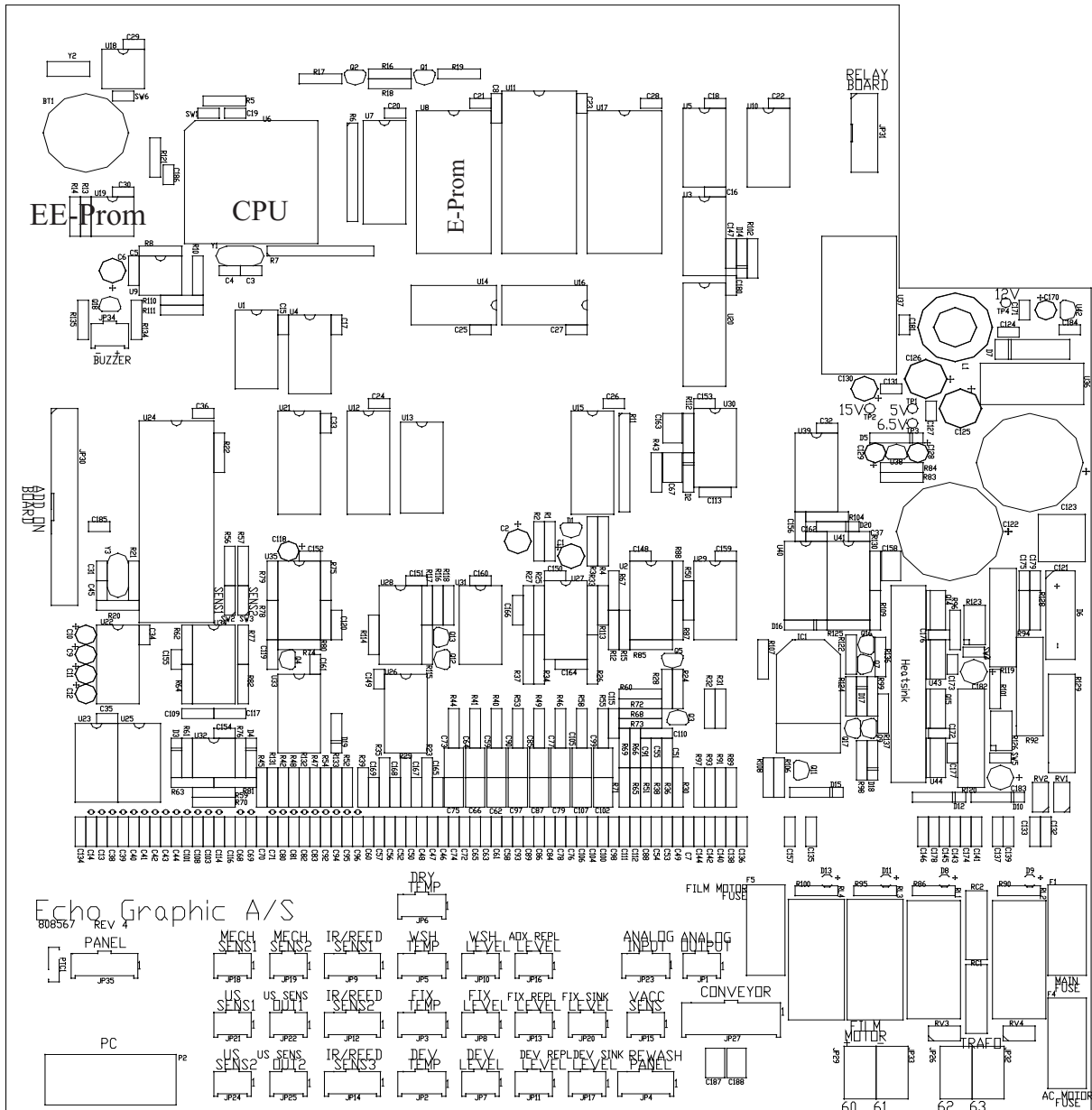

4080100A.DWG - REV 4

SECTION SEVEN: Electronic and Mechanical Diagrams

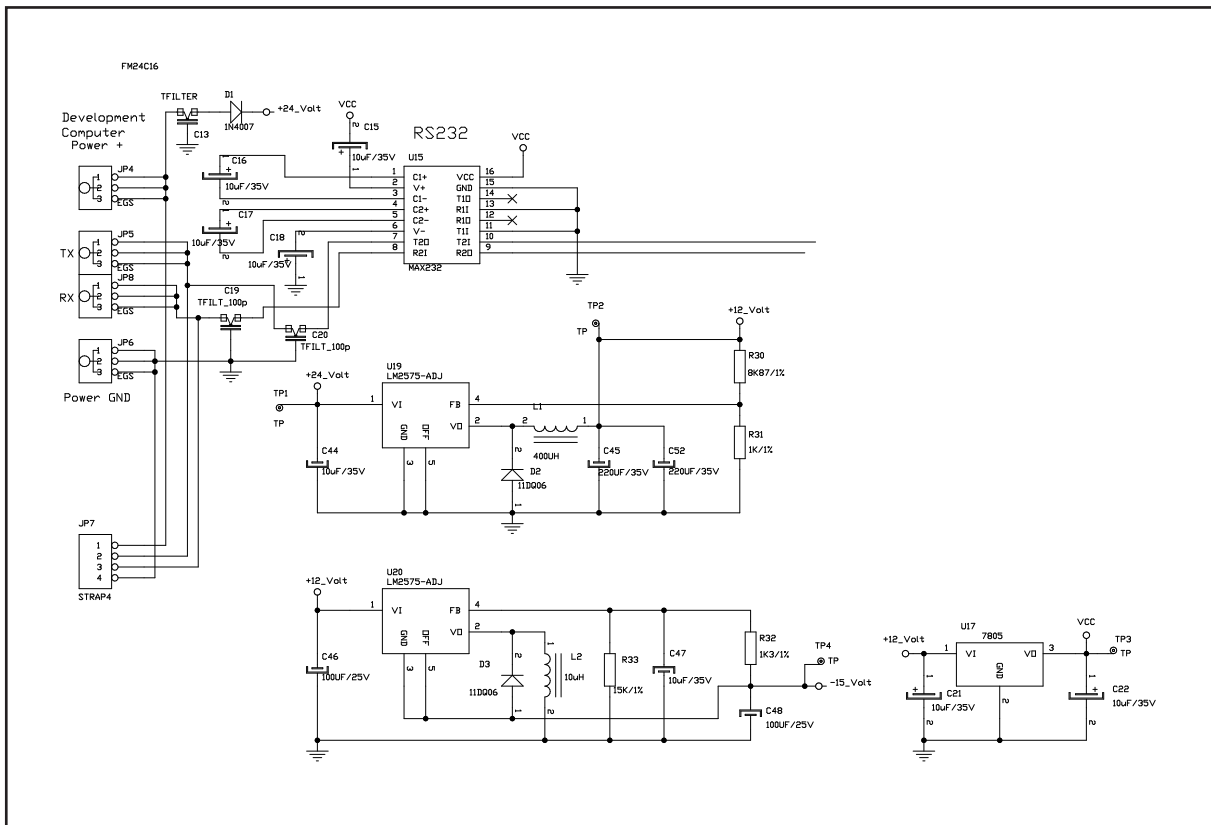

Display Communication Drawing 4080103a

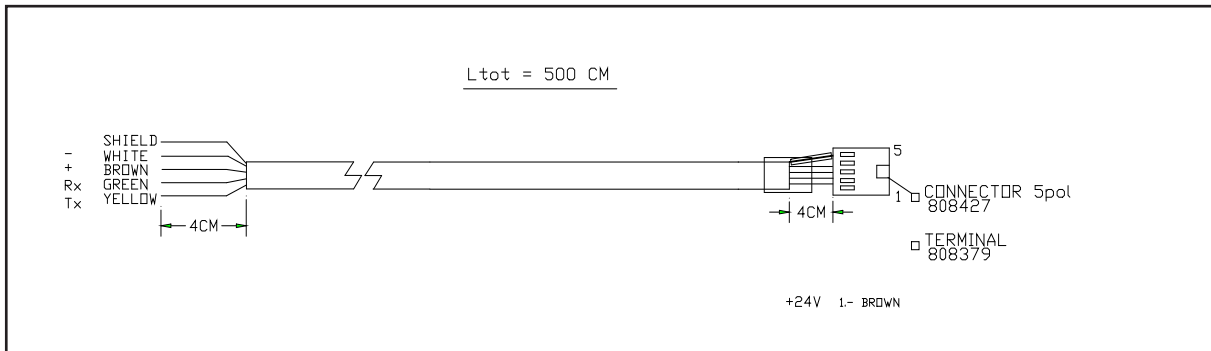

Cable between Mainbox and Panel Part nr. 890685

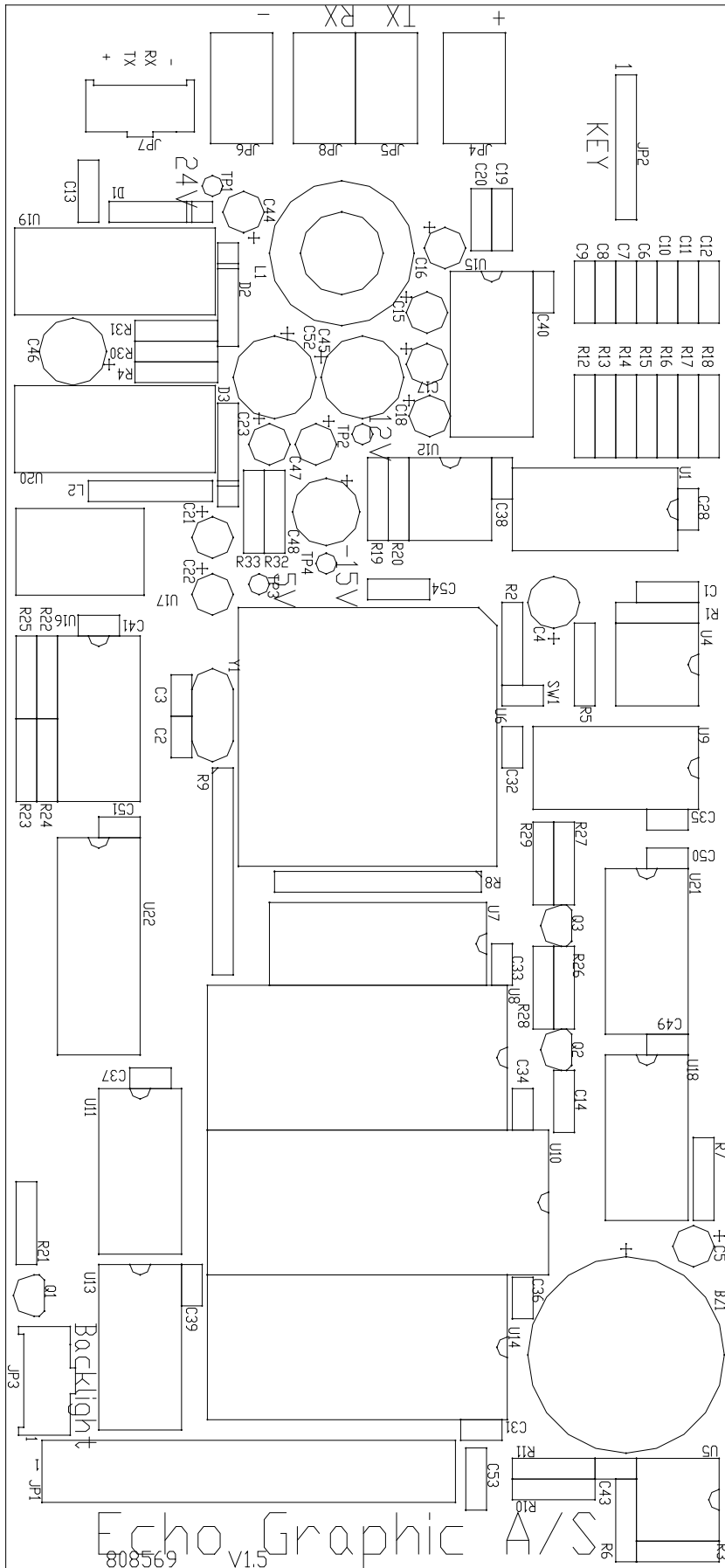

SECTION 7

