

Important

Your on-line processor has a built in exhaust blower. If the main switch is switched off, the blower is disconnected and chemical fumes can damage conveyor/imagesetter. Use the bulid in timer to control on/off/night mode of the processor to ensure that the exhaust blower is always running.

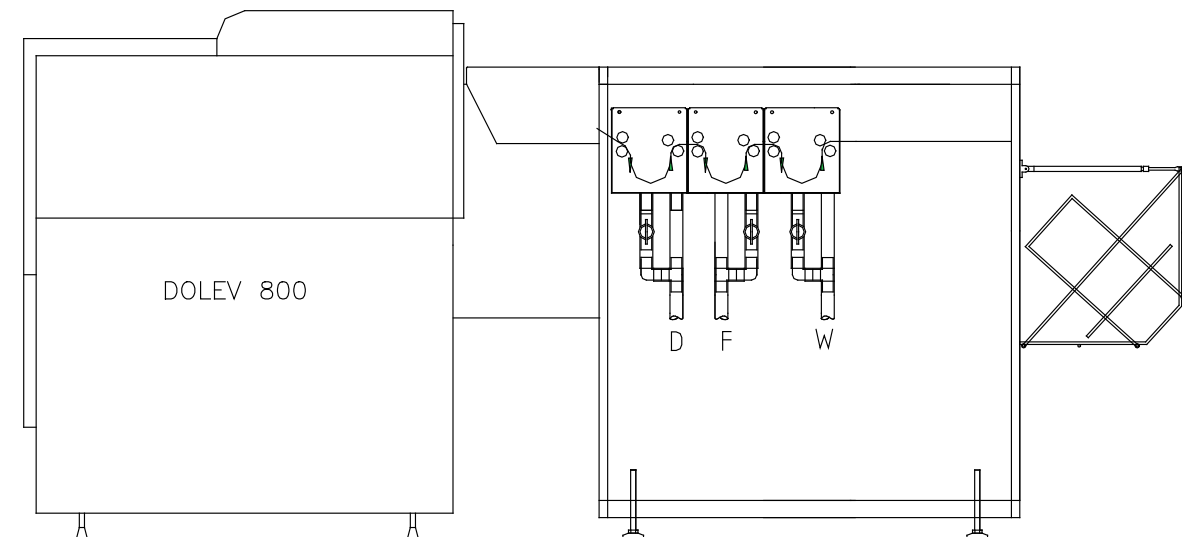

**Creo
Dolev 800 V / Dolev 800 V²⁻³**

**Hope / Carnfeldt
EG 900**

8.1 General

This section contains the processor's basic operating instructions for working on-line with an imagesetter.

Before operating the processor on-line, the procedures in section three Installation must be performed. Read this entire section and section four (Operation) before attempting to operate the processor.

8.2 Installation of On-Line Section

Special care should be taken when the processor is connected to imagesetter. Is advisable to install the imagesetter first. The imagesetter should be

“levelled” and be put in its final position before the developer is connected.

Install the processor as described in section three. Level the processor in to its final position before chemistry is added.

Connect the 9 pin interface cable to the conveyor. Turn the power on and test the installation.

Contents

8.1 General.....	89
8.2 Installation of On-Line Section.....	89
8.3 Conveyor Operation.....	91
Conveyor Timer Settings	91
Communication Signals.....	91
Timing diagram Dolev 800 on-line.....	92
State diagram Dolev 800.....	93
8.4 On-Line Drawings and Settings.....	94
Test of Ready Signal for Dolev 800.....	94
Interface PCB for Dolev 800, drawing 4080105	94
Interface PCB for Dolev 800 layout, drawing 890718	94
Cable - Conveyor / Imagesetter, Drawing 317749	95
Conveyor Overview Drawing.....	96
Conveyor Drawing 317739.....	97
R2 Gearwheel Position Left Side, Drawing 330489a.....	98
R2 Roller Position Right, Drawing 330489b.....	99
R2 Rack Side Right, Drawing 330489c.....	100
Rack Side Right Dry R38, Drawing 316108	101
Rack Side Section View Right/Left Dry R38, Drawing 316108	102
Interconnection drawing 6355	104
Block diagram 6359	105
Installationview 6325	106
Technical Specifications.....	107

Edition :7 November 2002





Product number:

317990 f. Dolev 800 V/V2

317991 f. Dolev 800 V³⁻⁴





8.3 Conveyor Operation

The operation of the conveyor is displayed on the left icon. Please observe the conveyor icons:



-  Empty conveyor, ready.
-  Film is being transported in to the conveyor
-  Film is in the conveyor.
-  Film has entered the processor.
-  Off-line feed.

 Settings of timer and conveyor speed are adjusted in the service menu. To access the service menu please see section 5.7

Communication Signals

To display the signals from the imagesetter use the information screen shown below. To access from the main menu push **S**  
 

For more information see section four

			
IN-PUT	CON1	CON2	CON3
1	0	0	0
PH01	PH02	PH03	PH04
1	1	1	1
	CONV. STATE		
	1		

Operation.

CONX - Status conveyor switches.

PHOX - Status signals from imagesetter.

CON1 - Conveyor sensor right or left
 Activated = 1.

PH01 - PH04 - Not used on Dolev 800

CONV. STATE (See state diagram page 93)

Conveyor Timer Settings

<u>Number</u>	<u>Settings V2/ V3-V4</u>	<u>Units</u>	<u>Description</u>
Conv. Timer 1	50/25	0,1 Sec	Ready delay: The time from activation of conveyor sensor wait is sent to imagesetter.
Conv. Timer 2	40/20	0,1 Sec	Conveyor motor delay: The time from the film has left the buffer to conveyor motor stop. Includes timer 3.
Conv. Timer 3	15/4	0,1 Sec	No-Feed delay: The time activation of the inlet sensor to conveyor motor stop.
Conv. Timer 4	-	0,1 Sec	Not used on Dolev.
Conv. Timer 5	40/40	Sec	Conv: Time out, error time out.

Conveyor/Photoset: CreoScitex Dol 800

Conv. motor speed1: 255

SECTION EIGHT: On-Line Description Creo Models

Timing diagram Dolev 800 on-line

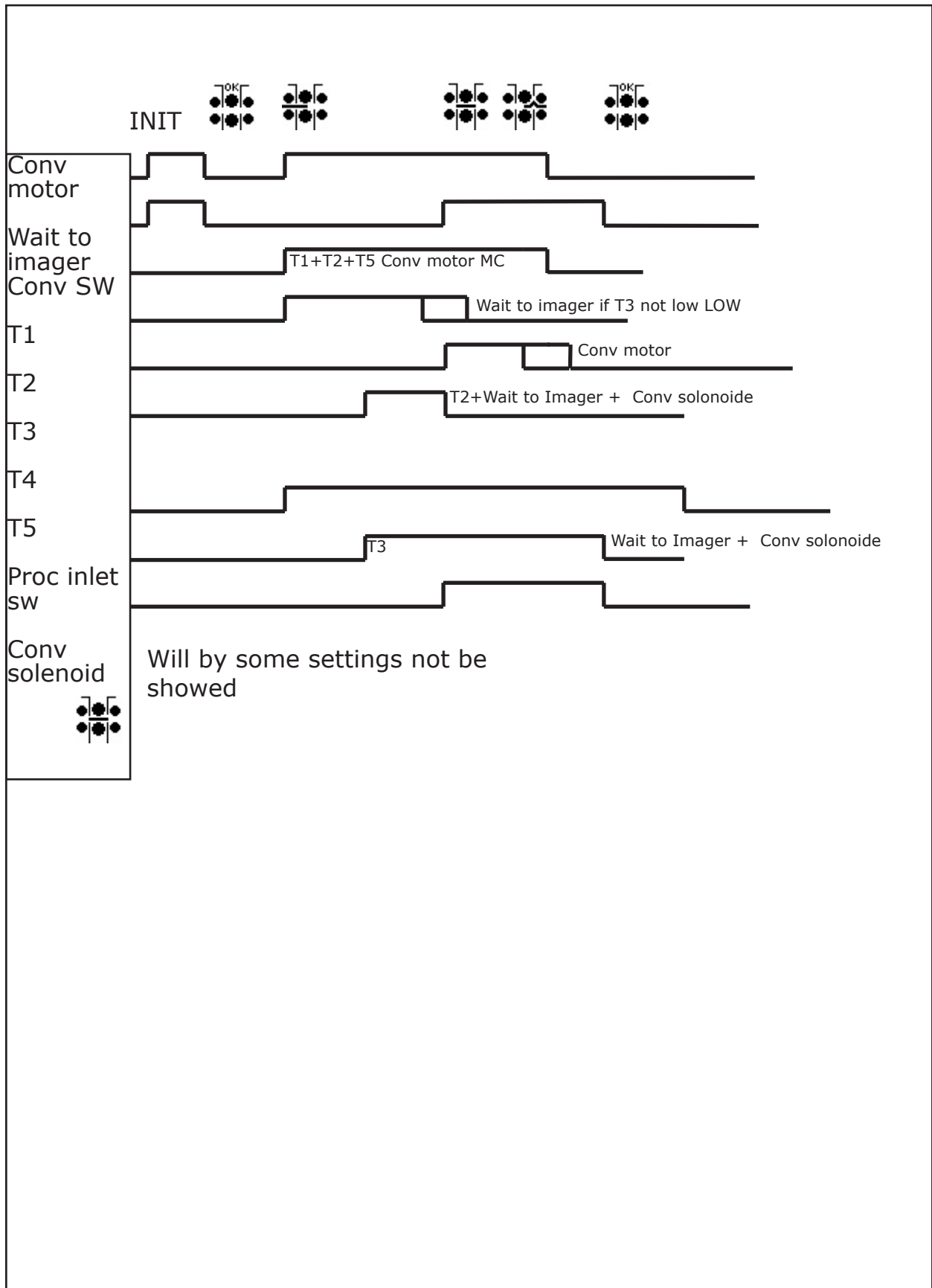

SECTION 8

SECTION EIGHT: On-Line Description Creo Models

C| = C ommand
A| = A ction

Dashed line is the normally process way.
Italic font is only for combi processor.

Default conv .timers are:
Conv . timer 1 = 5 sec. (50)
Conv . timer 2 = 4 sec. (40)
Conv . timer 3 = 1.5 sec. (15)
Conv . timer 5 = 40 sec. (40)

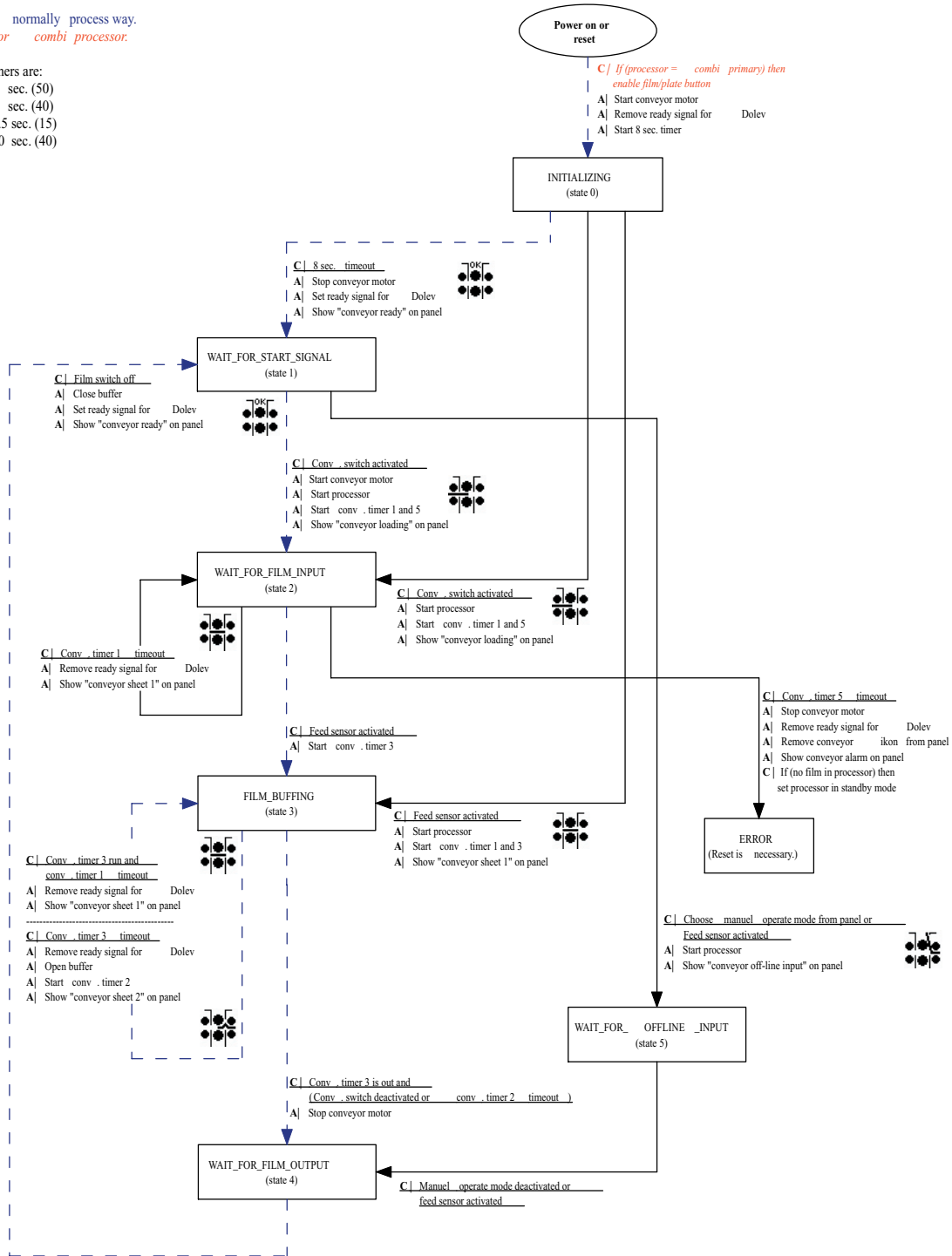

State diagram Dolev 800

DOLEV
800

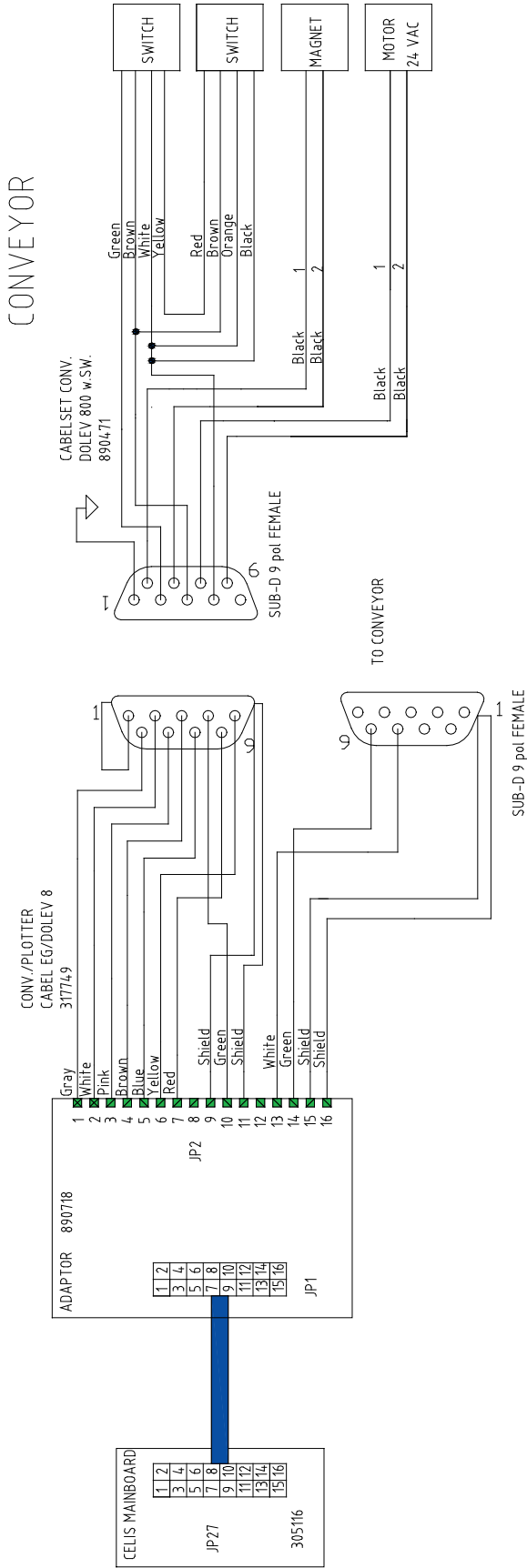

Conveyor diagram, Dolev 800, drawing 317795

SECTION EIGHT: On-Line Description Creo Models

8.4 On-Line Drawings and Settings

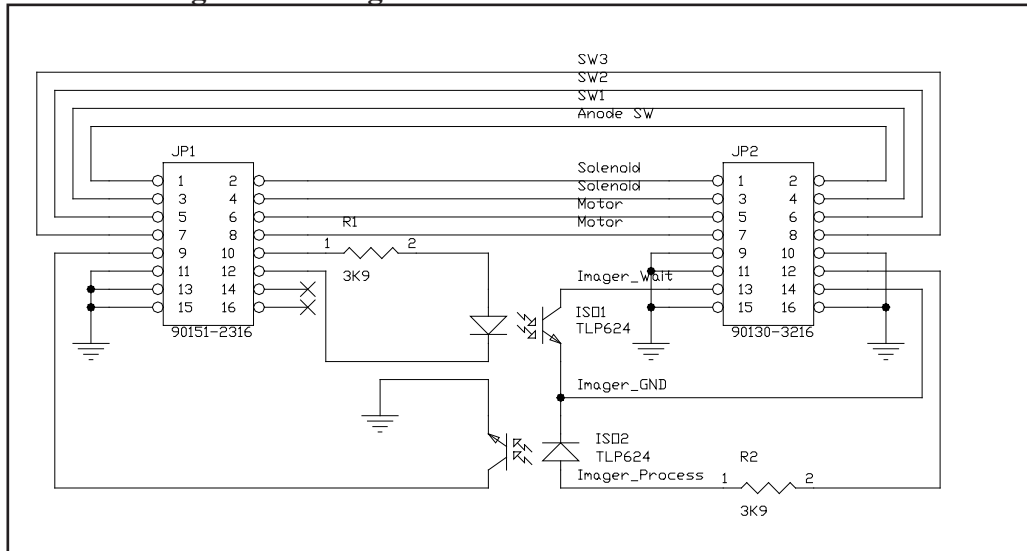

Interface PCB for Dolev 800, drawing 4080105

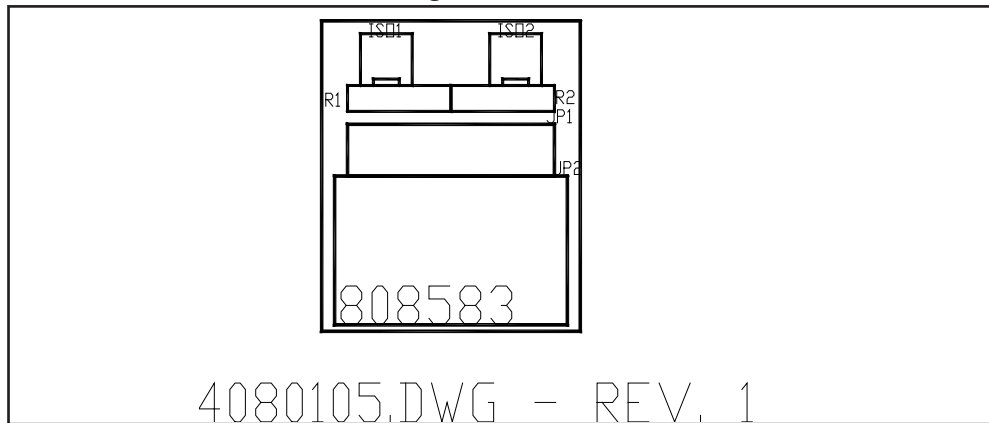

Interface PCB for Dolev 800 layout, drawing 890718

Test of Ready Signal for Dolev 800

1. Enter the service menu.
2. Select output.
3. Press the right arrow (Fig 1)
- Activate 1. DC MOTOR 1 (Fig 2).
4. The optocoupler ISO1 will be active until you press off or until you exit the service menu.

The interface PCB is placed on the conveyor sensor plug !

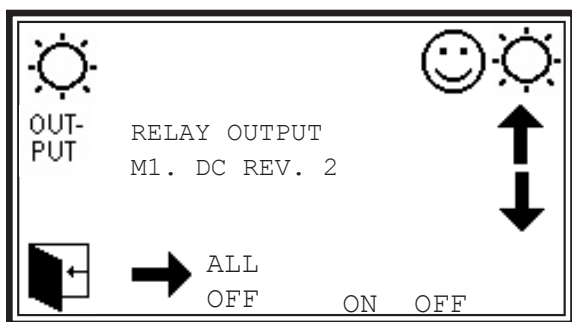

Fig 1

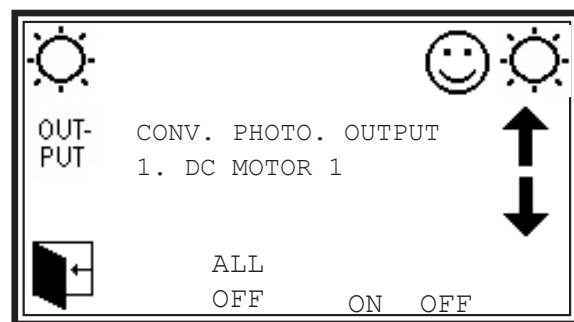
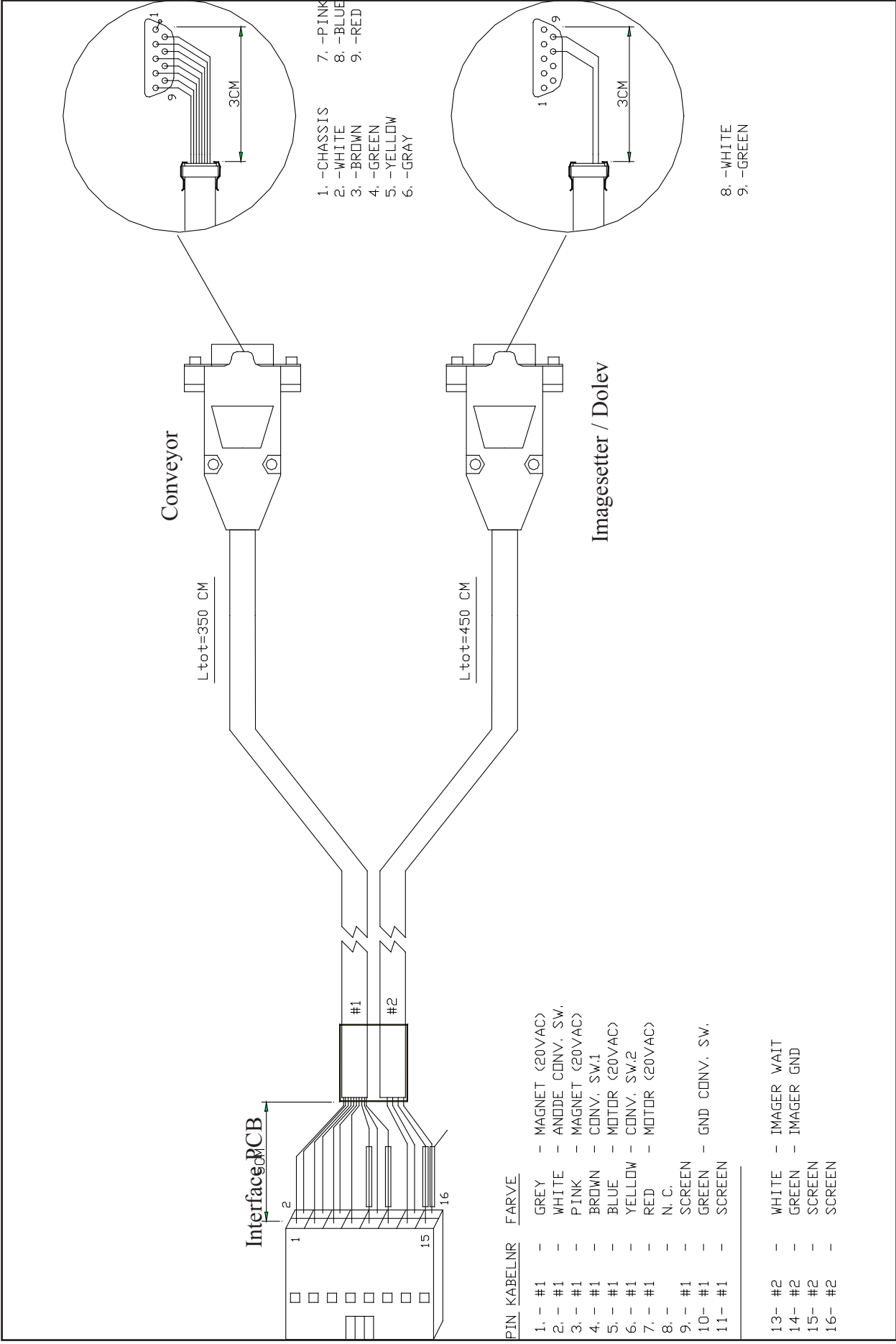

Fig 2

SECTION EIGHT: On-Line Description Creo Models

SECTION 8



PIN	KABELNR	FARVE
1-	#1	GREY - MAGNET (20VAC)
2-	#1	WHITE - ANODE CONV. SW.
3-	#1	PINK - MAGNET (20VAC)
4-	#1	BROWN - CONV. SW1
5-	#1	BLUE - MOTOR (20VAC)
6-	#1	YELLOW - CONV. SW2
7-	#1	RED - MOTOR (20VAC)
8-	-	N. C.
9-	#1	SCREEN
10-	#1	GREEN - GND CONV. SW.
11-	#1	SCREEN
13-	#2	WHITE - IMAGER WAIT
14-	#2	GREEN - IMAGER GND
15-	#2	SCREEN
16-	#2	SCREEN

Cable - Conveyor / Imagsetter, Drawing 317749

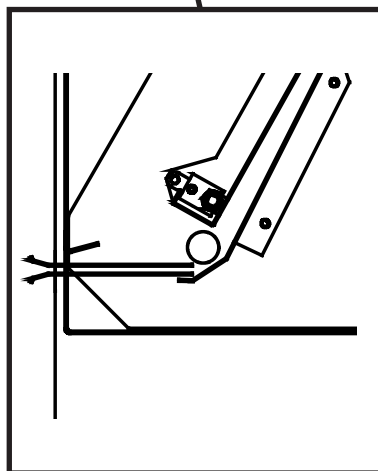
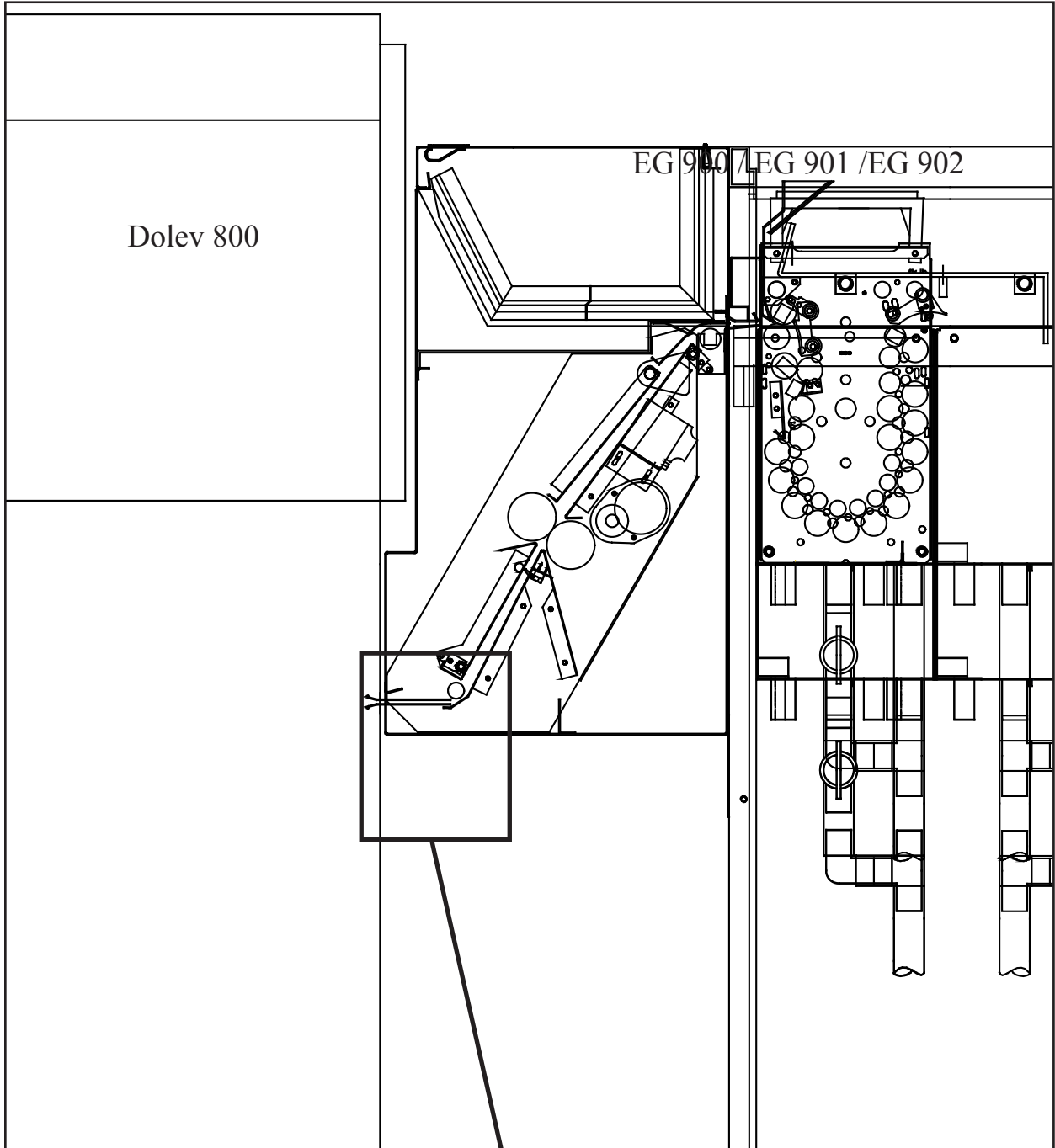

Conveyor Overview Drawing

Rackside, left.

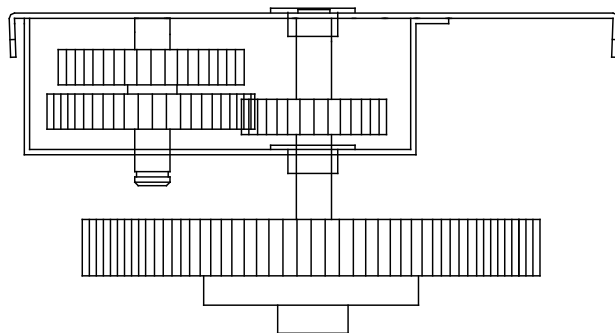
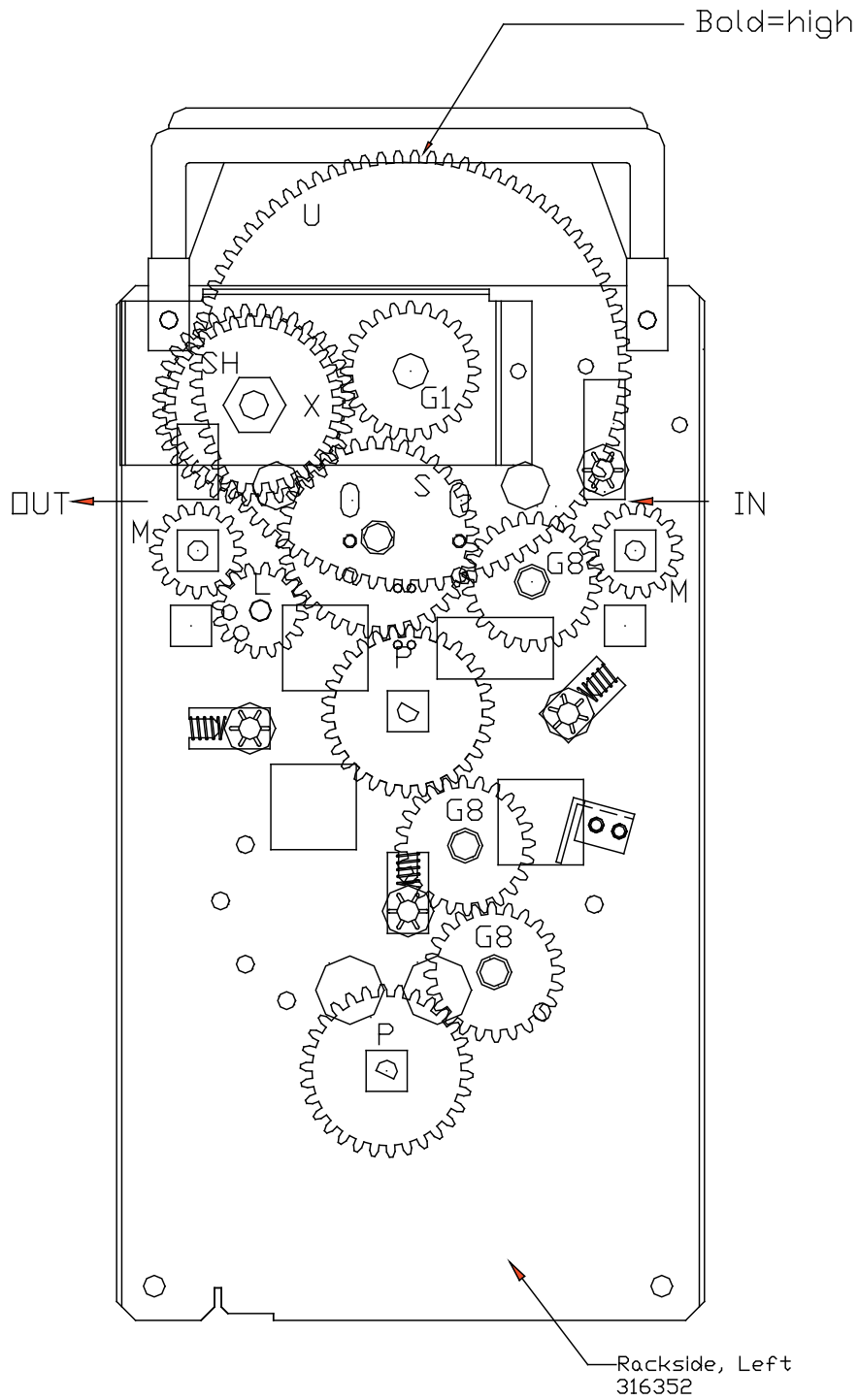

R2 Gearwheel Position Left Side, Drawing 330489a

SECTION EIGHT: On-Line Description Creo Models

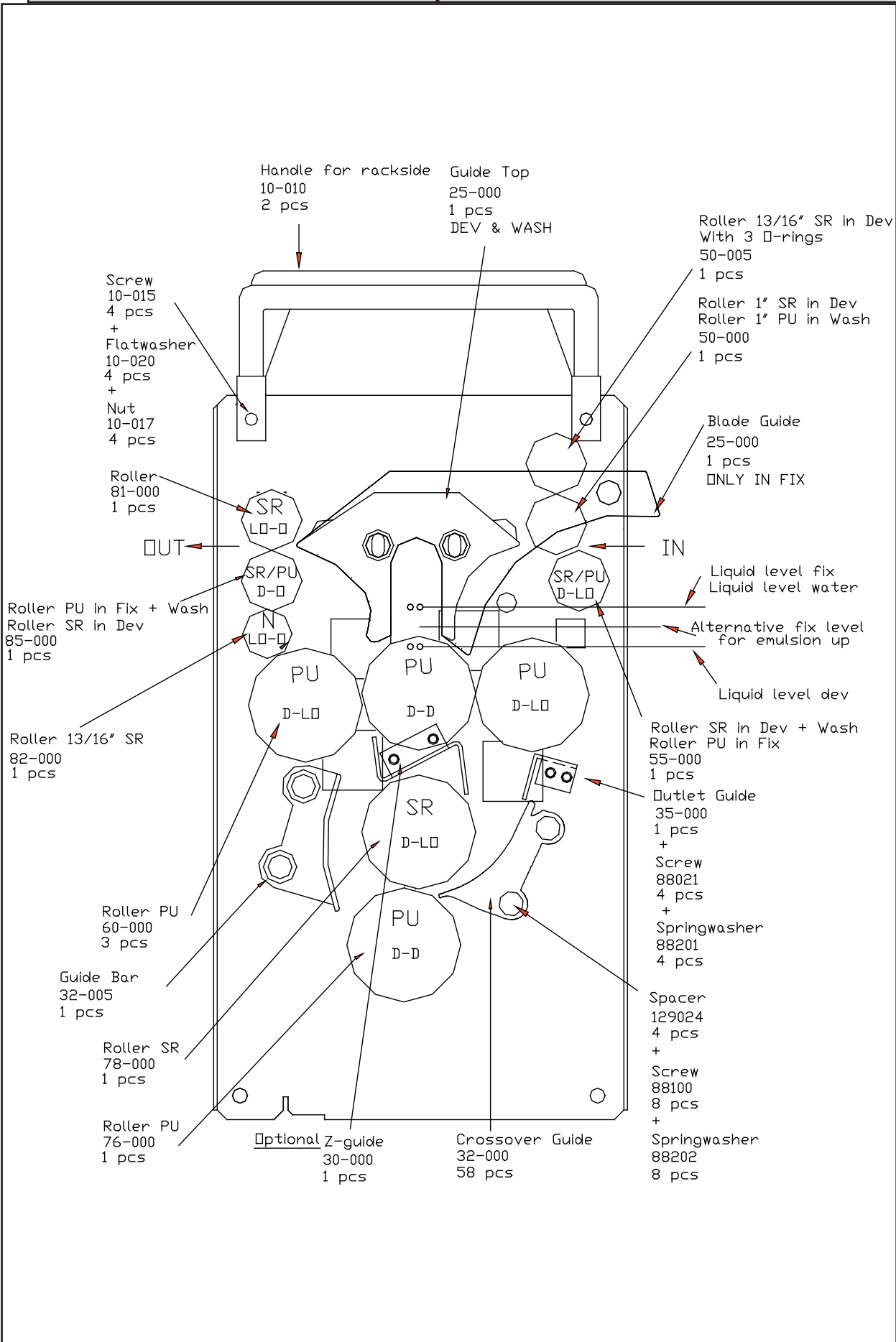

SECTION 8

R2 Roller Position Right, Drawing 330489b

SECTION 8

LEFT SIDE VIEW

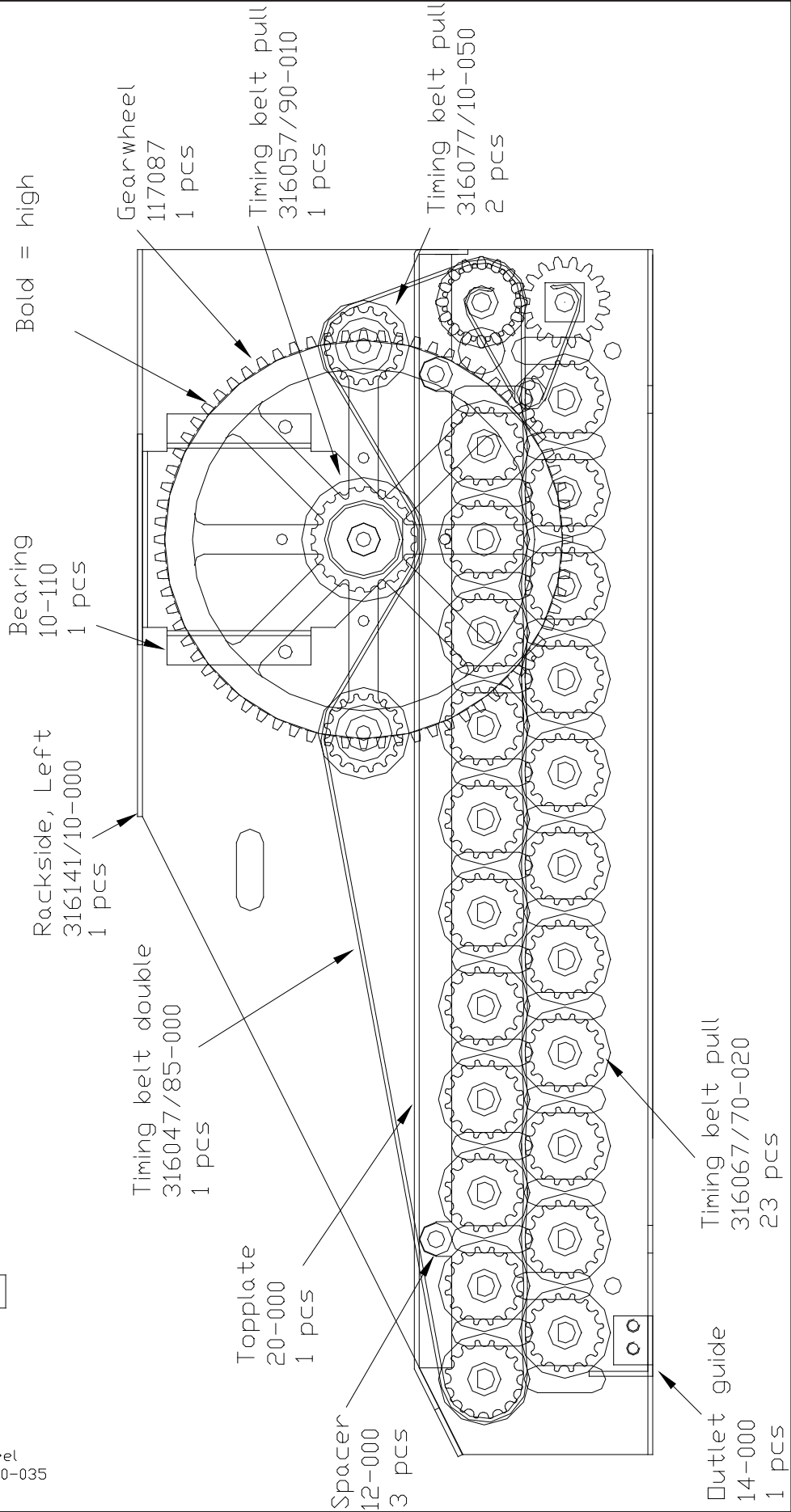
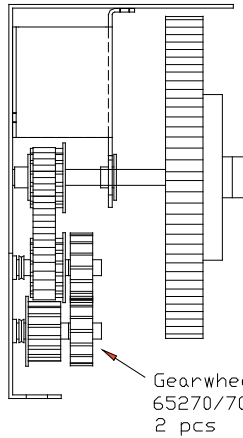

Rack Side Right Dry R38, Drawing 316108

SECTION EIGHT: On-Line Description Creo Models

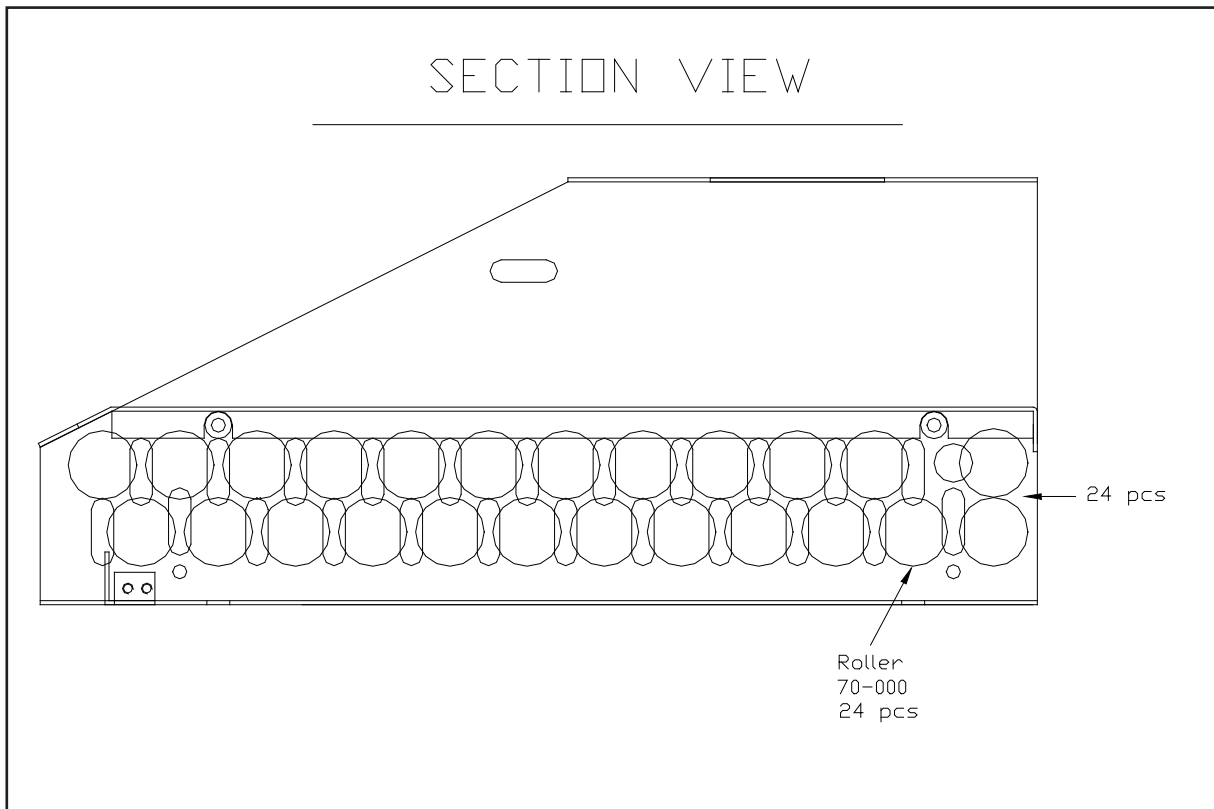
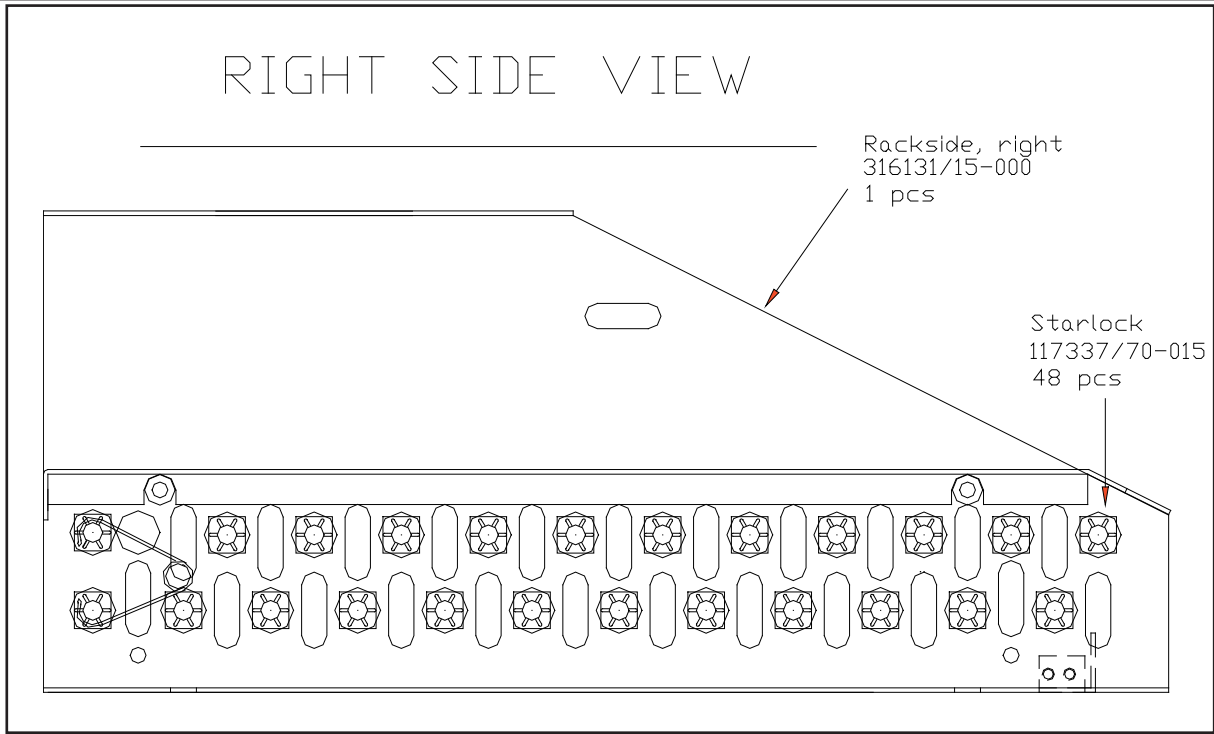

SECTION 8

Rack Side Section View Right/Left Dry R38, Drawing 316108

SECTION EIGHT: On-Line Description Creo Models

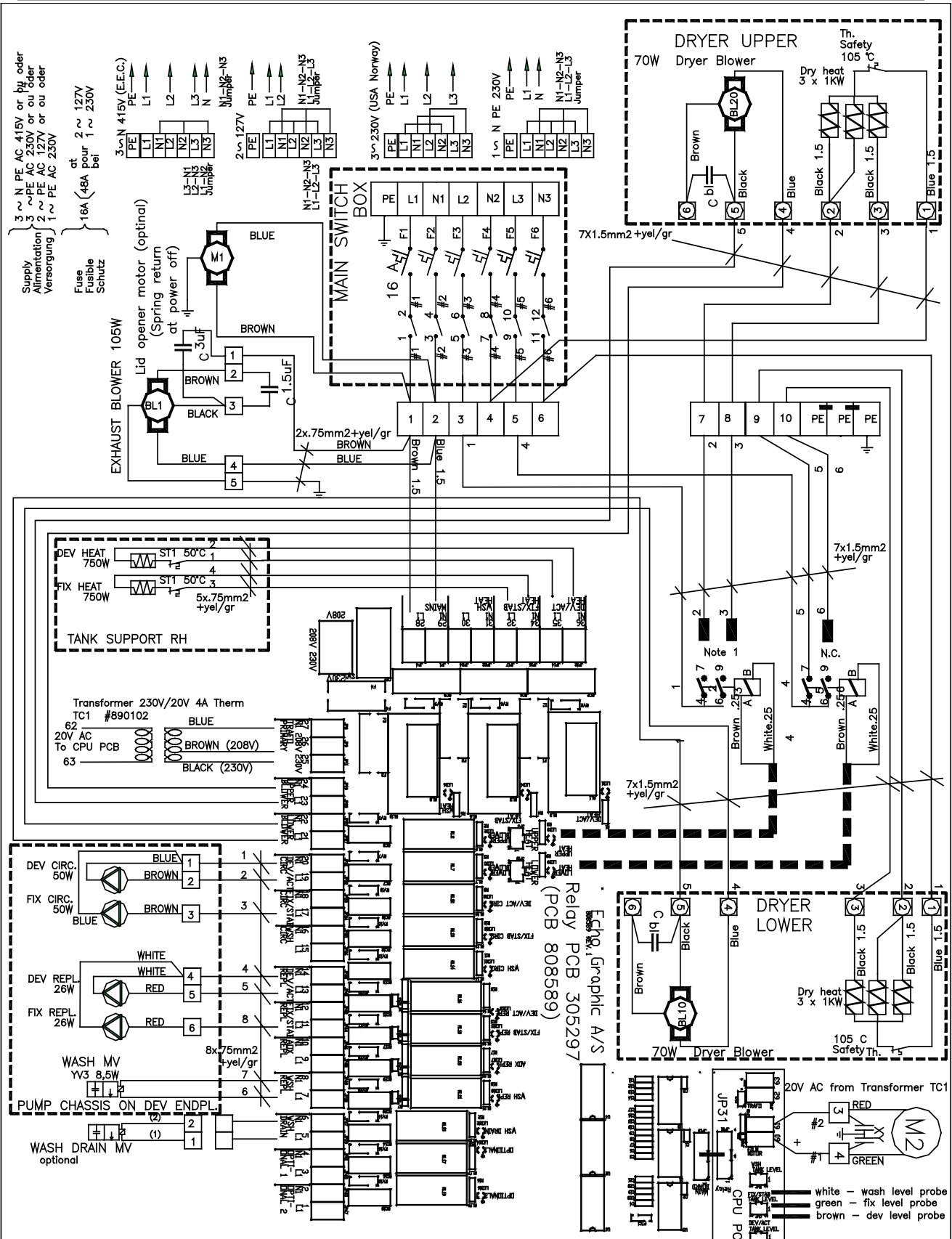

Note 1
 Wire #2 connected to relay pos 7 on EG/EP 900 and EP1140 only
 Wire #3 connected to relay pos 9 on EG/EP 750 only

See also Block diagram
 6359

Echo Graphic A/S Haandvaerkervej 2 DK-9560 Hadsund, Denmark Phone int.: +45 98 57 19 55 Fax int.: +45 98 57 15 91	Design/Draw : CV	Scale : :	Date : 10-01-02
	Name Interconn. diagram EG xx0		Drawing no. : 6355 D

SECTION 8

SECTION EIGHT: On-Line Description Creo Models

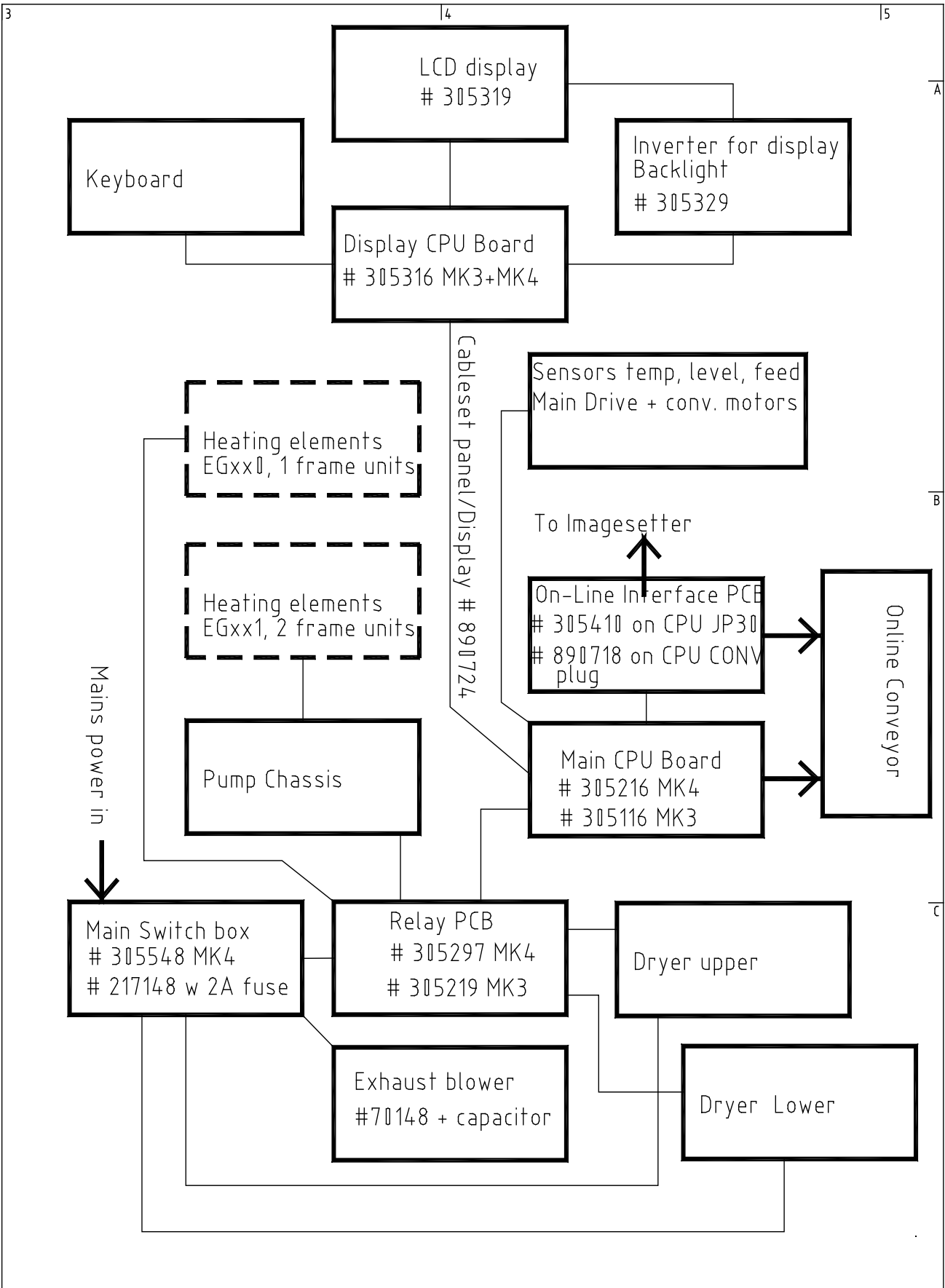

SECTION 8

Echo Graphic A/S Haandvaerkervej 2 DK-9560 Hadsund, Denmark Phone int.: +45 98 57 19 55 Fax int.: +45 98 57 15 91	Design/Draw : CV	Scale : :	Date : 10-01-02
	Name Block diagr. EG MK4	Drawing no. : 6359	

SECTION EIGHT: On-Line Description Creo Models

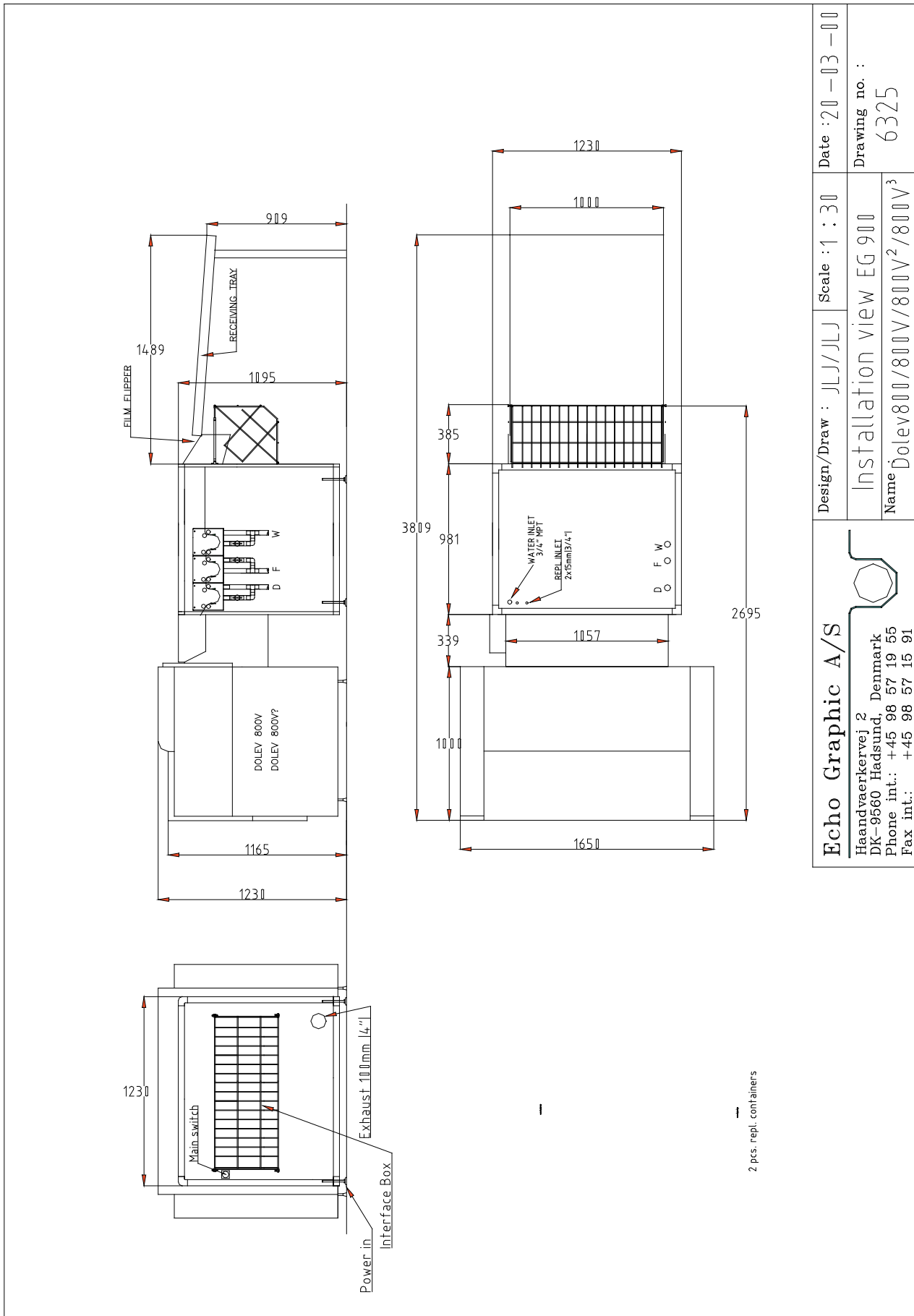

Echo Graphic A/S Haandvaerkervej 2 DK-9560 Hadsund, Denmark Phone int.: +45 98 57 19 55 Fax int.: +45 98 57 15 91	Design/Draw : JLJ/JLJ	Scale : 1 : 30	Date : 20 - 03 - 00
	Installation view EG 900 Name Dolev800V/800V²/800V³ Drawing no. : 6325		

SECTION 8

Installationview 6325

SECTION EIGHT: On-Line Description Creo Models

Hope / Carnfeldt On-Line Processors for Creo Imagesetters:

	EG 900, film	EG 901, film	EG 902, film	EGP 901,combi
Dimensions of on-line system				
Length	270 cm / 106.3"	292 cm / 115"	292 cm / 115"	349 cm / 137.4"
Width	165 cm / 65"	165 cm / 65"	165 cm / 65"	165 cm / 65"
Height	120 cm / 47.2"	120 cm / 47.2"	120 cm / 47.2"	123 cm / 48.4"
Shipping dimensions				
Length	175 cm / 68.9"	175 cm / 68.9"	175 cm / 68.9"	228 cm / 89.8"
Width	142 cm / 55.9"	142 cm / 55.9"	142 cm / 55.9"	142 cm / 55.9"
Height	129 cm / 50.8"	129 cm / 50.8"	129 cm / 50.8"	129 cm / 50.8"
Weight				
Net	300 kg / 661 lb.	395 kg / 871 lb	395 kg / 871 lb	540 kg / 1190 lb.
Gross	420 kg / 926 lb.	520 kg / 1146 lb.	520 kg / 1146 lb.	680 kg / 1500 lb.
Specifications				
Inlet width	91 cm / 36"	91 cm / 36"	91 cm / 36"	91 cm / 36"
Tank capacity	29 l / 7.7 US gal.	29 l / 7.7 US gal.	50 l / 13.2 US gal	29/16 l 7/3.6 US gal
Rack length dev.	32 cm / 12.6"	44 cm / 17.3"	67 cm / 26.4"	44/20 cm 17.3/7,8"
Developing time min.-max.	20 – 80 sec.	15 – 90 sec.	15 – 90 sec.	15 – 90 sec.
Speed at 30 sec. dev. time	64 cm/min. 25.2"/min.	88 cm/min. 34.6"/min.	134 cm/min. 52.8"/min.	88 cm/min. 34."/min.
Speed at 20 sec. dev. time	-	-	-	60 cm/min. 23.6"/min.
Max. film length off-line	5 m / 16.4 ft	10 m / 32.8 ft	10 m / 32.8 ft.	-
Min. film size off-line	18 x 10 cm 7 x 4"	18 x 10 cm 7 x 4"	18 x 10 cm 7 x 4"	-
Max. format (set by imagesetter)	86 x 121 cm 34 x 47"	86 x 121 cm 34 x 47"	86 x 121 cm 34 x 47"	86 x 121 cm 34 x 47"
Dev./fix./wash temperature range	20 - 45°C 68 - 113°F	20 - 45°C 68 - 113°F	20 - 45°C 68 - 113°F	20 - 45°C 68 - 113°F
Exhaust blower	Built in	Built in	Built in	Built in
Exhaust connection	Ø 10 cm	Ø 10 cm	Ø 10 cm	Ø 10 cm
Circulation rate dev., fix.	10 l/min. 2.7 US gal./min.	22 l/min. 2.7 US gal./min.	22 l/min. 2.7 US gal./min	22 / 10 l/min 2.7 /1.3 US gal.
Circulation rate wash	-	22 l/min. 2.7 US gal./min	22 l/min. 2.7 US gal./min	22 / 10 l/min 2.7 /1.3 US gal.
Water consumption (operate)	3.5 l/min. 0.9 US gal/min.	3.5 l/min. 0.9 US gal/min.	3.5 l/min. 0.9 US gal/min.	3.5 l/min. 0.9 US gal/min.
Emission of heat to room (operate)	2000 W	2400 W	2400 W	3000 W
Water connection	¾" pipe thread	¾" pipe thread	¾" pipe thread	¾" pipe thread
Drain connection	3x1" hose nipple	3x1" hose nipple	3x1" hose nipple	6x1" hose nipple
Replenishment containers	Dev./fix. 30 l	Dev./fix. 30 l	Dev./fix. 30 l	4 x 30 l.
Max. power consumption	5900 VA	5900 VA	5900 VA	9400 VA
Average power consumption:				
Operate	5000 W	5000 W	5000 W	6200 W
Power save	1000 W	1000 W	1000 W	3500 W
Night mode	600 W	600 W	600 W	1100 W
Power supply:				
1x230ACV+/-10% / 50/60Hz	30 amp	30 amp	30 amp	40 amp
3x230ACV+/-10% / 50/60Hz	-	3 x 16 amp	3 x 16 amp	3 x 16 amp