

**Important**

**Your on-line processor has a built in exhaust blower. Even if the main switch is switched off, the blower will still be on. This is to prevent chemical fumes in the conveyor/imagesetter. If a timer is connected in series with the main power cable, the processor has to be modified, so that the exhaust blower is always running.**

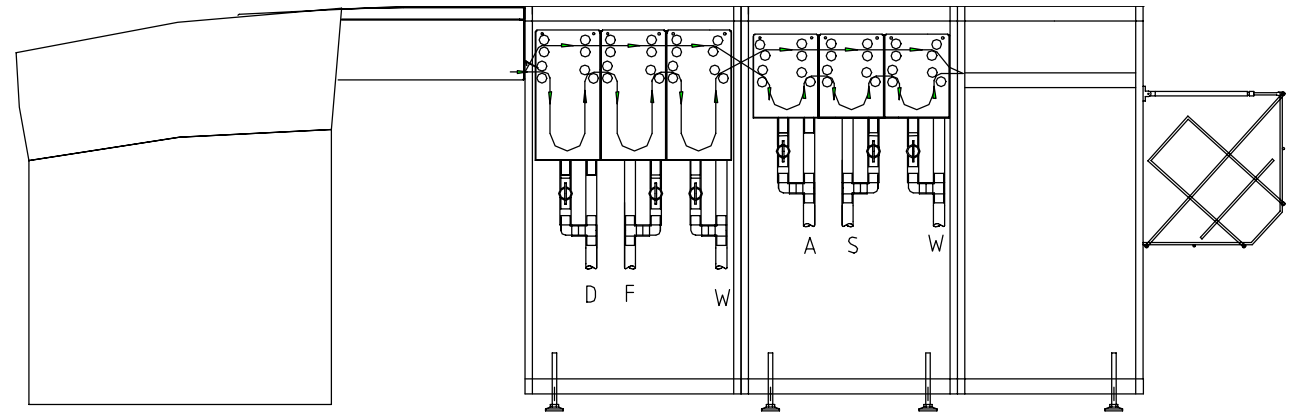

**Heidelberg  
Primesetter 74**

**Hope / Carnfeldt  
EGP 901 for film and polyester plate**

**8.1 General**

This section contains the processor's basic operating instructions for working on-line with a Primesetter.

*Before operating the processor on-line, the procedures in section three Installation must be performed. Read this entire section and section four (operation) before attempting to operate the processor.*

advisable to install the imagesetter first. The imagesetter should be "levelled" and be put in its final position before the processor is connected.

Install the processor as described in section three. Level the processor to its final position before chemistry is added.

Connect the 25 pin interface cable to the conveyor. Turn power on and test the installation.

**8.2 Installation of On-Line Section**

Special care should be taken when the processor is connected to an imagesetter. It is

# Contents

8.1 General.....	89
8.2 Installation of On-Line Section .....	89
8.3 Conveyor Operation .....	91
Conveyor Timer Settings .....	91
Communication Signals .....	91
8.4 On-Line Drawings and Settings .....	92
Conveyor Timing Diagram .....	92
Combi Description .....	93
Processing Polyester Plates .....	94
Interface Diagram, Drawing 4080106a .....	96
Interface Board Location, Drawing 4080102 .....	97
Jumper Settings with Heidelberg Primesetter .....	97
Setting up the Mido Interface .....	98
OLP Settings without Speedway .....	99
OLP Settings with Speedway .....	99
Interconnection Modul, Drawing 464609 .....	100
Cableset Conveyor C-box, Drawing 464424 .....	101
Cableset Interconn - Mido 464422 .....	101
Conveyor, Drawing 464580 .....	102
Conveyor, Drawing 464580 .....	103
8.5 Rack Drawings On-Line .....	104
Dev1 Rack 36" R44 Combi, Drawing 324719 .....	104
Fix1 Rack 36" R44 Combi, Drawing 324729 .....	105
Wash1 Rack 36"R44 Combi, Drawing 324739 .....	106
Rack Side l.w.Gears Dev./Fix. R44 Combi, Drawing 5788 .....	107
Rack Side r.w.Gears Dev./Fix. R44 Combi, Drawing 5792 .....	108
Rackside l.w.Gears Wash R44 Combi, Drawing 5789 .....	109
Rack Side r.w.Gears Wash R44 Combi, Drawing 5793 .....	110
Fix. Rack/Act. Rack 36"R20 Combi E\C\sh, Drawing 5975a .....	111
Wash2 Rack 36"R20 Combi E\C\sh, Drawing 5975b .....	112
Rack Side l.w.Gears R20, Drawing 324815 .....	113
Rack Side r.w.Gears R20, Drawing 324825 .....	114
R33 Horizontal Dryer Roller Position, Drawing 5930 .....	115
R33 Horizontal Dryer Gearwheel Position Left Side, Drawing 5930 .....	116
R33 Horizontal Dryer Gearwheel Position Right Side, Drawing 5930 .....	117
Installationview 6316 .....	119
Installationview 6323 .....	120
Technical Specifications for Primesetter 74 .....	121
Technical Specifications for Primesetter 102 .....	122

Edition: 8 Februar 2001

Product number:

**464810**

**464910**

### 8.3 Conveyor Operation

To indicate the operation of the conveyor the left icon changes according to the → signal coming from the Primesetter and to the position of the film/plate. Please observe the conveyor icons:



Empty conveyor, ready.



Film is being transported in to the conveyor.



Film is being cut.



Film is in the conveyor.



Film has entered the processor.



Off-line feed.



Settings of timer and conveyor speed are adjusted in the service menu. To access the service menu please see section 5.7

#### Conveyor Timer Settings

<u>Number</u>	<u>Settings</u>	<u>Units</u>	<u>Description</u>
Conv. Timer 1	1	0,1 Sec	<b>Must not be changed.</b>
Conv. Timer 2	14	0,1 Sec	<b>Ignore switch time:</b> The time in which a feed signal is ignored if the conveyor switch is activated.
Conv. Timer 3	5 (0)	0,1 Sec	<b>Cut delay:</b> Should not be changed (0 when the conveyor has “open/close function”)
Conv. Timer 4	15	0,1 Sec	<b>No feed delay:</b> The time from activation of the inlet sensor to the conveyor motor stops.
Conv. Timer 5	40	Sec	<b>Conv:</b> Time out, error time out.
Conveyor/Photoset	8. Heidelberg		<b>On-Line Type</b>
Conv. motor speed1	135		<b>Speed after CUT</b>
Conv. motor speed2	255		<b>Speed during FEED</b>

### Communication Signals

To display the signals from the Primesetter use the information screen shown below. To access from the main menu push **S** → . For more information see section four Operation.

IN-PUT	CON1	CON2	CON3	CON4
0	0	1	0	1
PH01	PH02	PH03	PH04	
0	1	0	1	

CONX - Status conveyor switches.

PHOX - Status signals from imagesetter.

PH01 - **Ready** - Imagesetter ready always on.

PH02 - **Cut** - End of CUT, active low.

PH03 - **Feed** - Feed to conveyor (in some cases the signal must be set up in the Primesetter).

PH04 - Not used

The signals can also be displayed on the Mido PCB. See page 8.98.

**8.4 On-Line Drawings and Settings**

**Conveyor Timing Diagram**

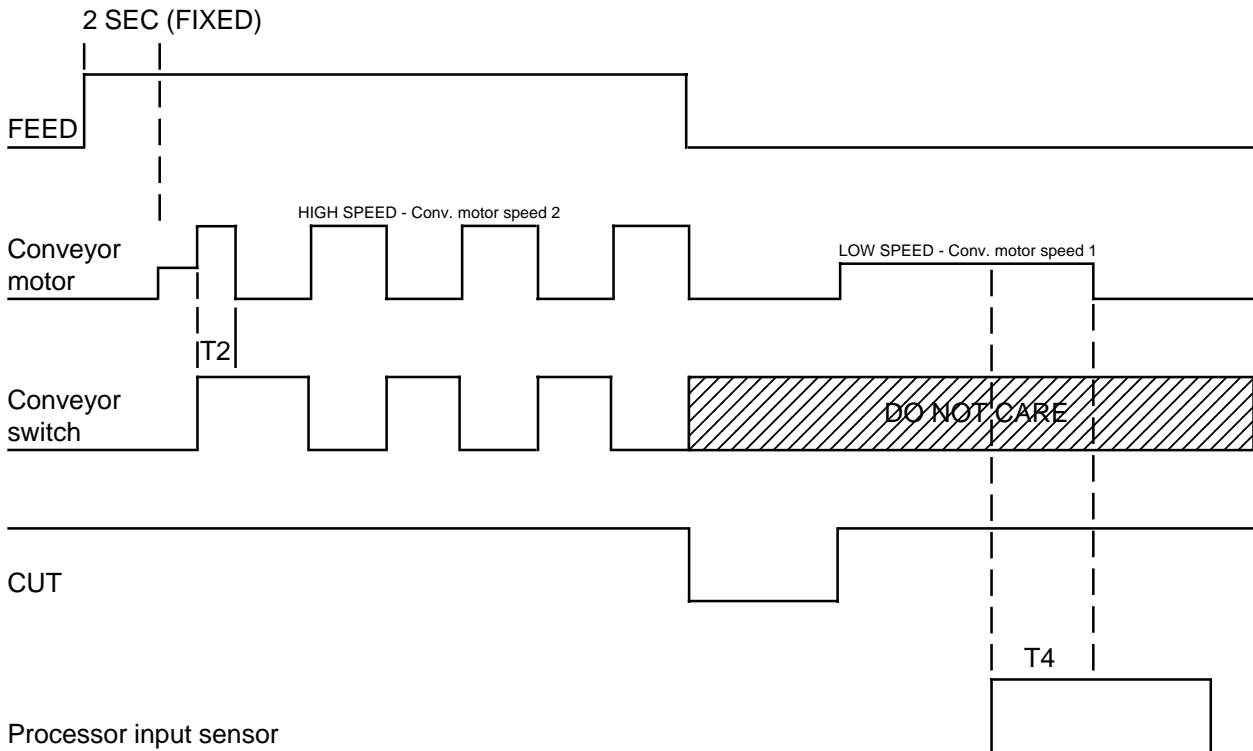

The FEED signal from imagesetter. The feed signal is ON when the Primesetter feeds material out in the conveyor. If the FEED signal is missing and the material is feed out without the conveyor starting, ask a Heidelberg engineer to check the parameters in the Primesetter.

The conveyor motor starts and stops depending on activation of the inlet switch in the conveyor. When the switch is not activated the conveyor motor is on and if switch is activated the conveyor motor is off.

The CUT signal from the Primesetter is normally “1” but it changes to “0” when film is cut in the imagesetter.

The processor input sensor stops the conveyor after a small delay (timer 4).

**Combi Description**

The EGP Combi on-line processor is designed to work on-line for normal film and polyester plate in one and same processor. The processor is equipped with two developer sections - one for normal film and one for polyester plate. The processor has one common dryer section and one common input sensor. Based on a signal for the Primesetter the Combi on-line processor will guide the film/ polyester plate to the correct developer section in the processor. (Some processors may have a manual icon F/P). Refer to the drawing on the next page.

The EGP Combi on-line processor is equipped with two complete sets of the Celis Control electronics. One Celis Control is connected to the developer section for film and the other is connected to the developer section for polyester plates. In the following the film control will be called the **primary control** and the polyester plate control will be called the **secondary control**.

All communication with the imagesetter goes through the interface board connected

to the primary control, which again is connected to the secondary control through a serial communication cable.

When powering on the processor without material change signal from the imagesetter activated, the processor will be in film mode. This means that the primary control is in charge of the imagesetter communication, input sensor, the drive motor speed and the dryer temperature.

When the imagesetter activates the material change signal, the primary control will tell the secondary control to activate the diverter guide in the inlet of the processor and take charge of the imagesetter communication, input sensor, the drive motor speed and the dryer temperature.

The physical connection of the input sensor, the drive motor and the dryer section is on the primary control.

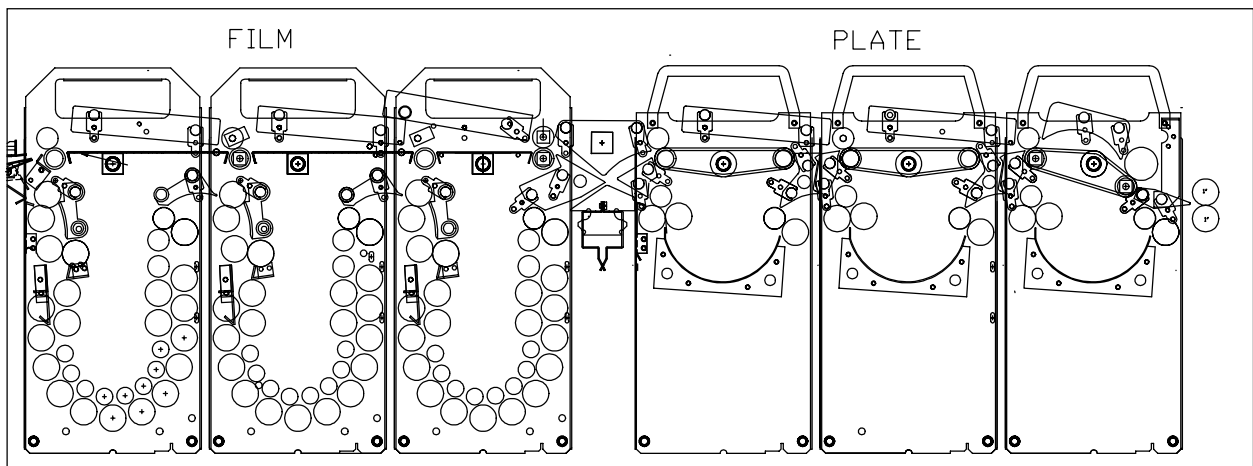

**Processing Polyester Plates**

High quality print work and uniform results are only possible if the processing conditions are absolutely consistent. Scratch free, uniform processing is essential. You can check whether or not your processor processes uniformly with the aid of an unexposed silver plate.

Process an unexposed silver plate at 20, 25 and 30 sec. Then look for the best compromise of the brightest silver image. The one with the most uniform colour over the printing area usually has the best development. Remember that the first end (up to 60mm) and the last end (up to 30mm) is used for clamping in the press and will not be printed. On some of these parts you can expect scratches due to the transport in the processor (see drawing of plate page 95).

Please follow these guidelines to ensure unproblematic operation with polyester. Note the following, when working with Mitsubishi material and chemistry:

**Polyester Plate Material**

- Polyester plate should be stored in dry and stable temperature conditions.
- The polyester plate should not be stored more than one year.

**Activator SLM-AC**

- Activator temperature should be between 28-31°C.
- Processing time should be between 20 to 30 sec. (Agfa 20).
- pH value approximately 13,7. Replace it if less than 12,8.
- Replenishment rate about 150 cc/sqm. (AGFA G5200b 120 cc/sqm.)

**Stabilizer SLM-ST**

- Stabilizer temperature should be about room temperature.
- Processing time should be between 20 to 30 sec. (Agfa 20).
- pH value approximately 6,0 – Replace if more than 7,0.
- Replenishment rate about 200 cc/sqm. (AGFA G5400b 120 cc/sqm.)

**Wash**

- Ensure that the wash section is clean from algae.
- Drain the wash tank and let it stay dry over weekends.
- Do not use chlorine (bleach) for cleaning.

**Dryer**

- The drying temperature should be about 40-50 °C.

**General Use**

The result will change in case of abnormal conditions such as:

- Long time where the chemistry has not been used. If it has not been used, the result can change (it might not be visible). A complete change of the chemistry is advisable every month.
- If there are problems, you may benefit by adding a little old chemistry to the new fresh chemistry (the new can be too active on the first 5-8 sheets).
- High evaporation will cause changes of the final result.
- If the laser intensity is adjusted too low, longer processing time cannot correct the quality of

## SECTION EIGHT: On-Line Description Heidelberg Models *Combi*

- Different batches of plate material may have different emulsion. A calibration of exposure and processing should therefore be performed when changing batch.

If one or more of the conditions are not correct, you can sometimes see problems such as:

- Transport problems: Scratches, white lines on the silver part.
- Reduced print capacity, e.g. only 5000 prints.
- Increased sensitivity: Fingerprints are easily seen on the silver part of the polyester plate (the polyester plates are always sensitive).
- Problems with density.

These are only a few of the parameters that will influence the work with polyester plate. Echo Graphic only has influence on the developing part. Basically, only the manufacturers of the plate can evaluate the result. When using materials not mentioned here please contact the manufacturer for developing parameters. More information about the entire process with Silver Digiplate can be obtained in the technical guide from Mitsubishi.

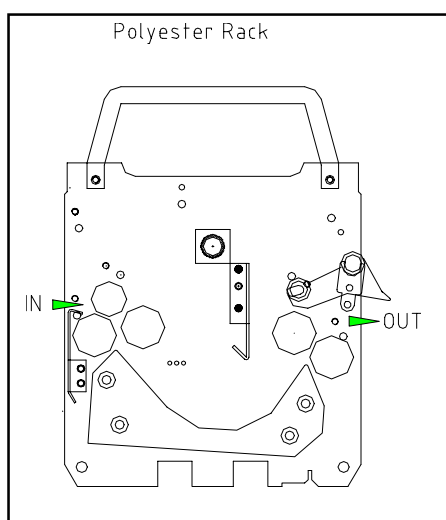
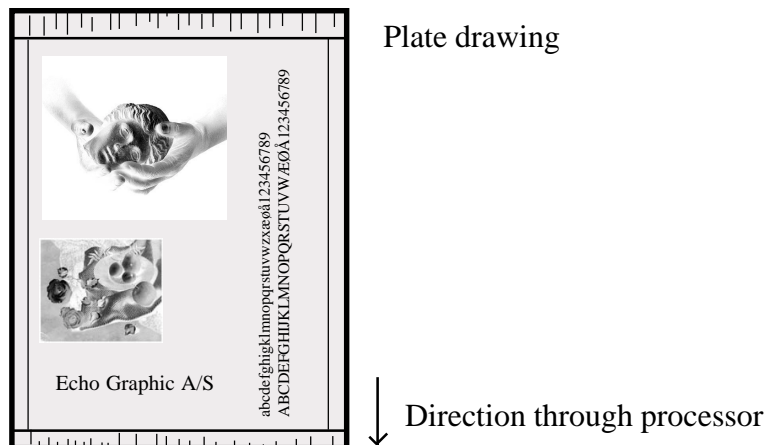

Side view of the newest version of polyester racks with blade guides. Imagesetters with a feed where the emulsion is down can be different (like the conventional rack).

# SECTION EIGHT: On-Line Description Heidelberg Models *Combi*

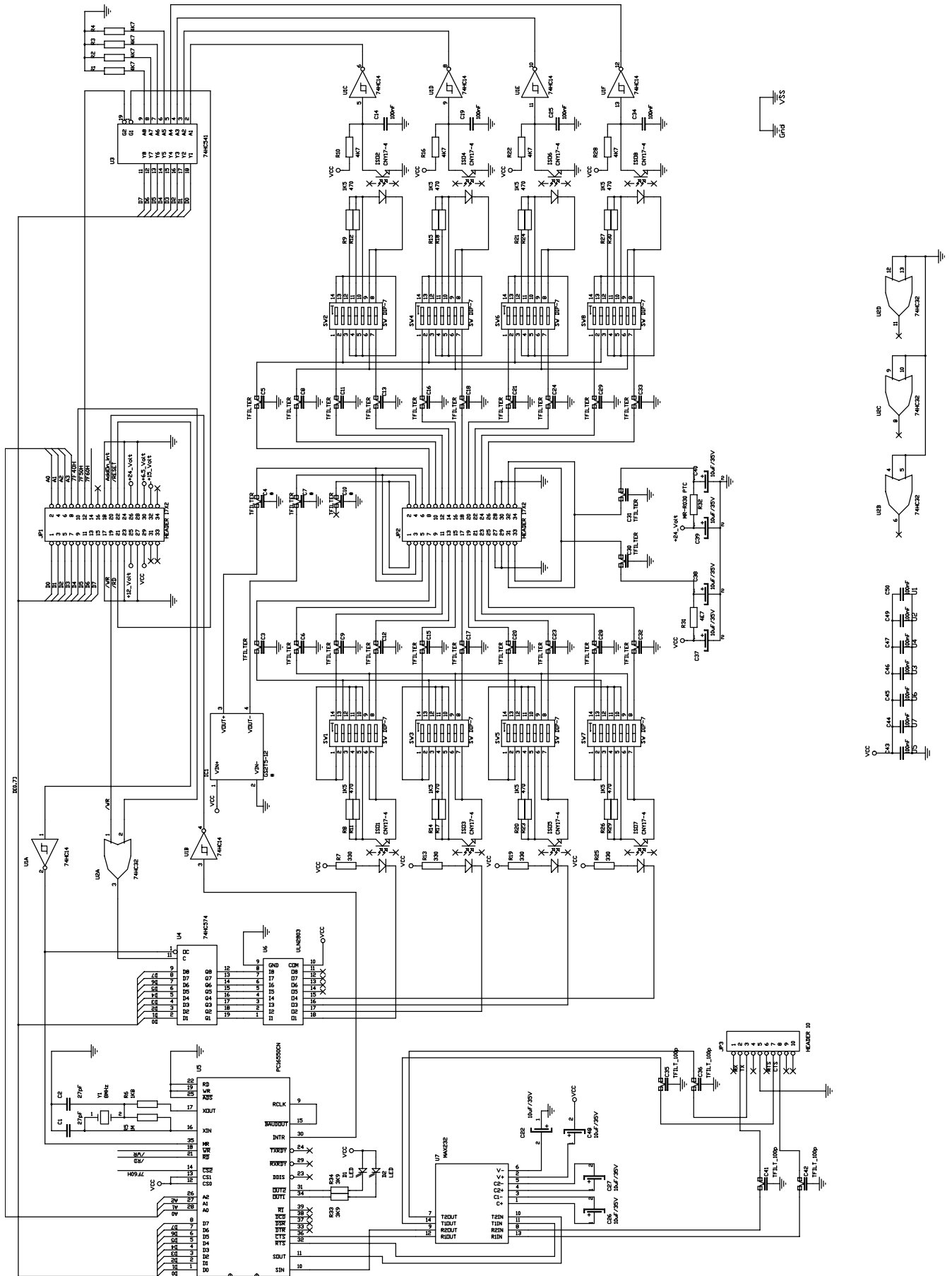

## SECTION 8

Interface Diagram, Drawing 4080106a

# SECTION EIGHT: On-Line Description Heidelberg Models *Combi*

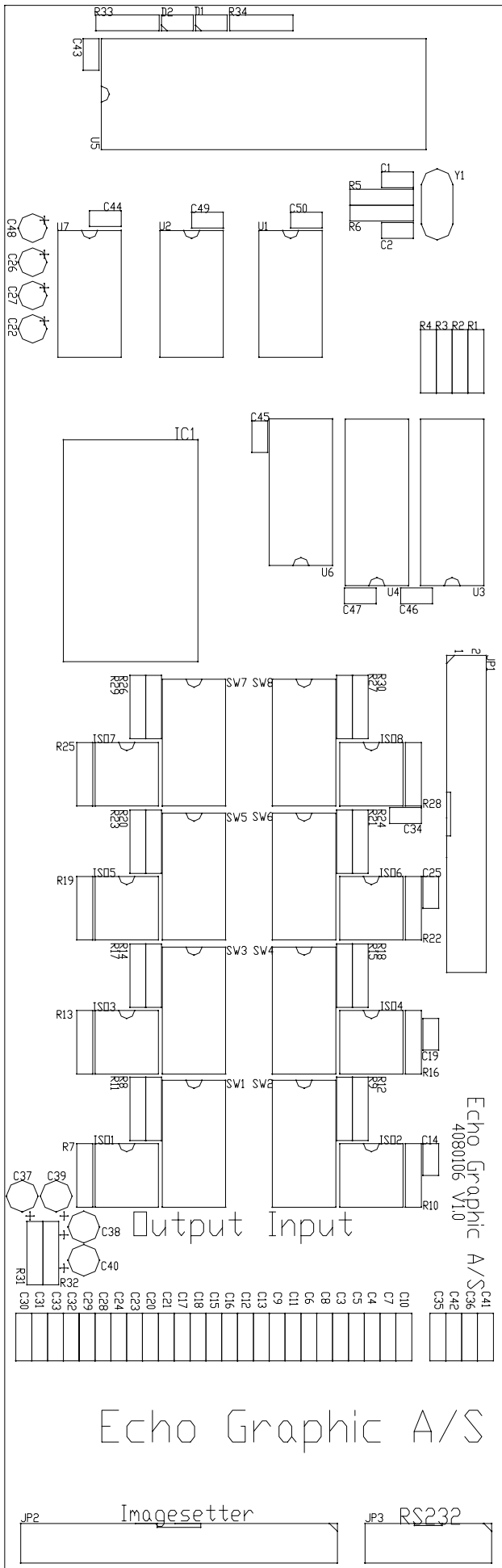

## Jumper Settings with Heidelberg Primesetter

SW/DIP	1	2	3	4	5	6	7
1	ON			ON		ON	
2	ON		ON				ON
3	ON		ON				ON
4	ON		ON				ON
5	ON		ON		ON	ON	ON
6	ON		ON				ON
7							ON
8							

## SECTION EIGHT: On-Line Description Heidelberg Models *Combi*

### Mido Description

The MIDO PCB controls the IR communication between the Heidelberg Primesetter and the Hope/Carnfeldt Celis electronics. The PCB controls both the serial and HW communication

### Setting up the Mido Interface

Before operating the system please ensure that the settings are correct. The settings are as follows:

### Default Settings

S1 Reset of Mido interface

S2

- 1 ON Int. IRDA ON
- 2 ON Ext. MIRDA Disabled
- 3 OFF Test inactive
- 4 OFF Option inactive

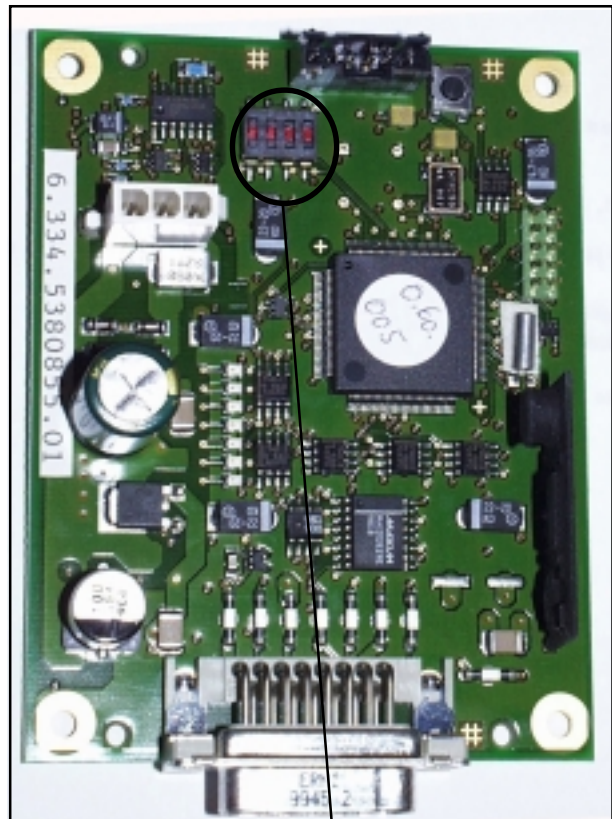

Mido Interface

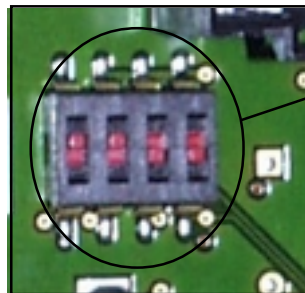

S2 settings

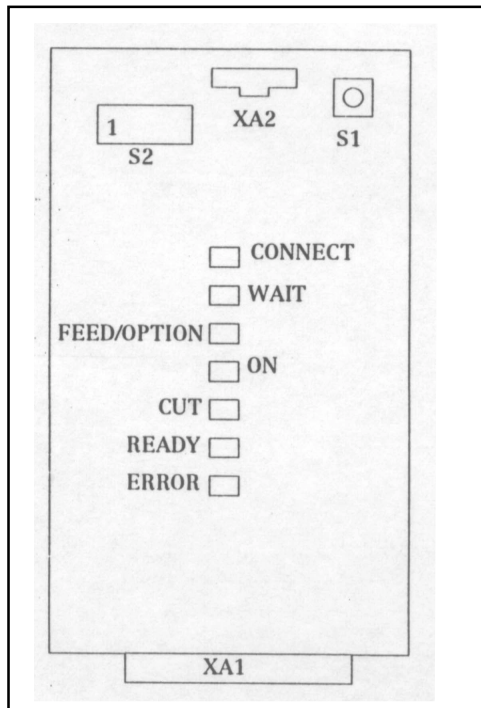

Diodes Mido Interface 464405A

### Diode Description

**CONNECT:** On-line bridge is connected HW.

**WAIT:** On-line bridge is not ready.

**FEED/OPTION:** On when film is sent.

**ON:** On-Line bridge is on.

**CUT:** Film is being cut

**READY:** Primesetter ready

**ERROR:** Film jam or other error.

When the mido pcb #464405 has power, some of the diodes will always be on!!!

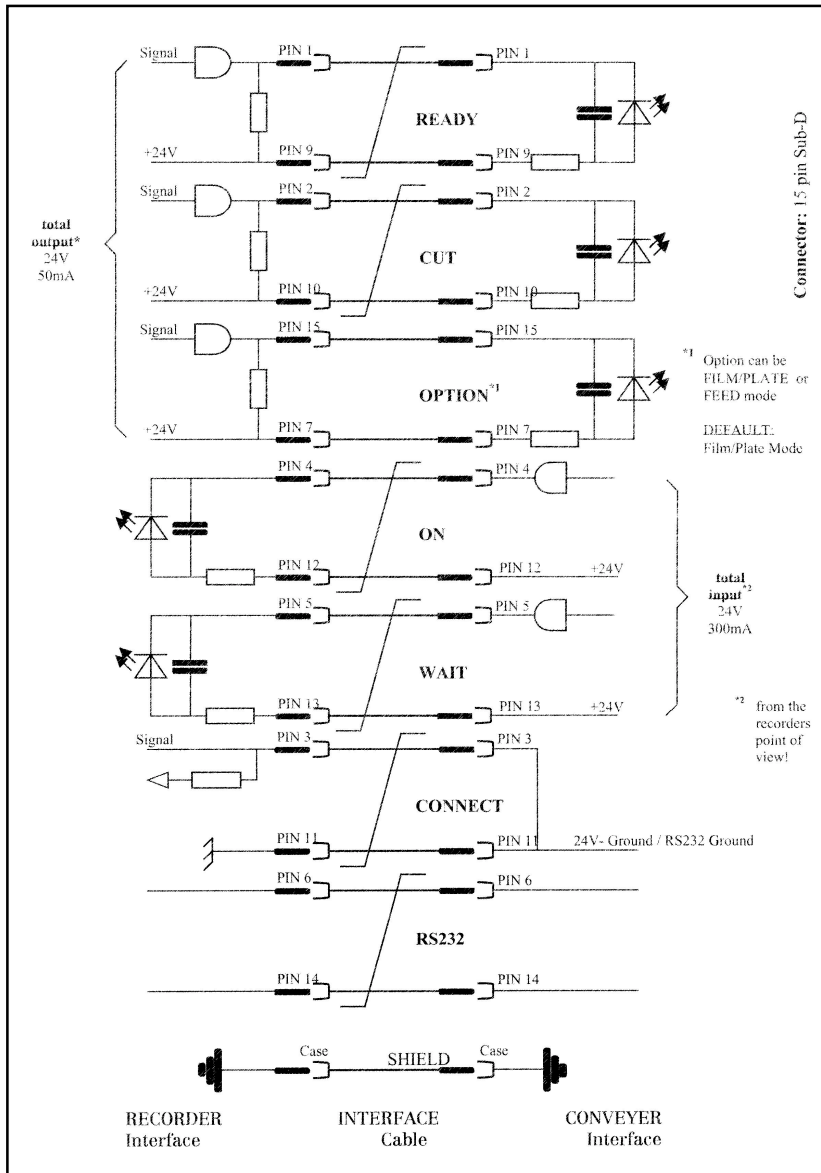

Diagram of the Mido interface, drawing 464405

**OLP Settings without Speedway**

By installation please make sure that the OLP parameters are set-up for Hope/ Carnfeldt on-line bridge. The following PID parameters should be checked:

- |                  |                               |
|------------------|-------------------------------|
| <b>21013</b> "1" | <b>Use Online Developer</b>   |
| <b>21014</b> "1" | <b>Mode Output device</b>     |
| <b>21310</b> "0" | <b>Mode OLP Communication</b> |
| <b>21304</b> "0" | <b>Use OLP SpeedWay</b>       |
| <b>21437</b> "1" | <b>Use OLP Feed Signal</b>    |

Serial communication with the imagesetter is supported from software version 2.0. The settings can be changed. The setting can be changed.

**OLP Settings with Speedway**

With speedway communication you can display the Hope/Carnfeldt processor's program setting on the Primsetter main menu. Please ensure that the PID parameters are changed to:

- |                  |
|------------------|
| <b>21013</b> "1" |
| <b>21014</b> "1" |
| <b>21310</b> "3" |
| <b>21304</b> "1" |
| <b>21437</b> "1" |

When the PID changes have been made the system must be rebooted. For further information please check the documentation of the Primsetter.

# SECTION EIGHT: On-Line Description Heidelberg Models *Combi*

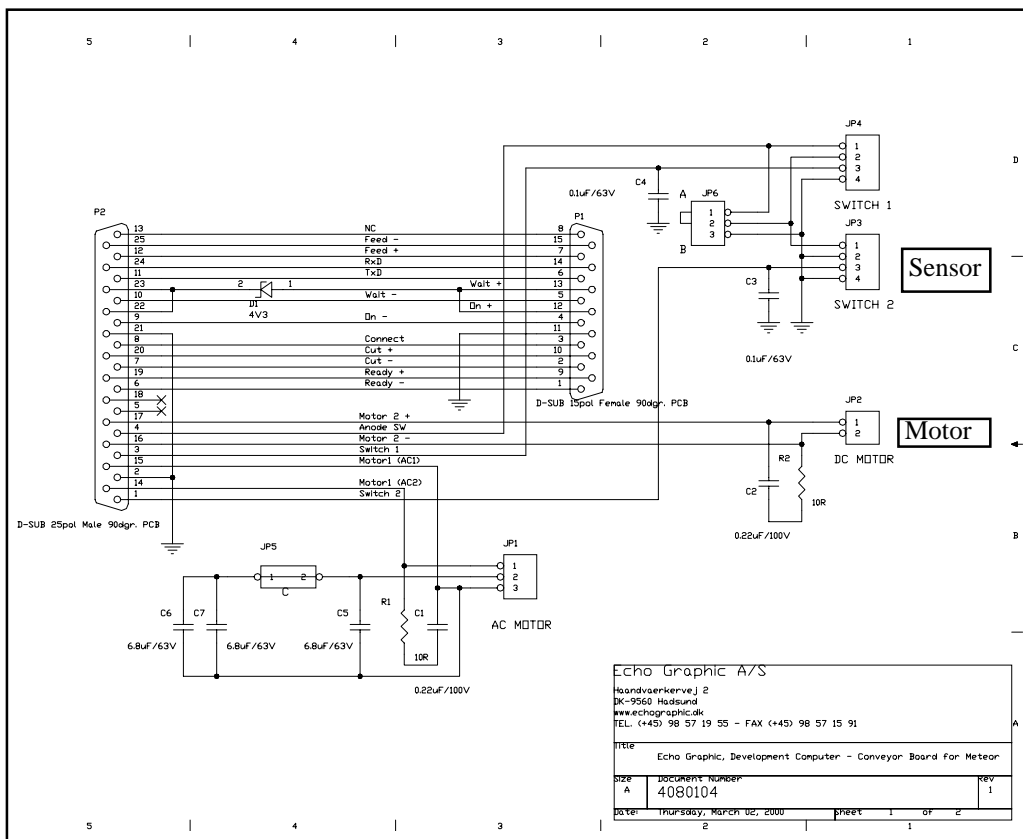
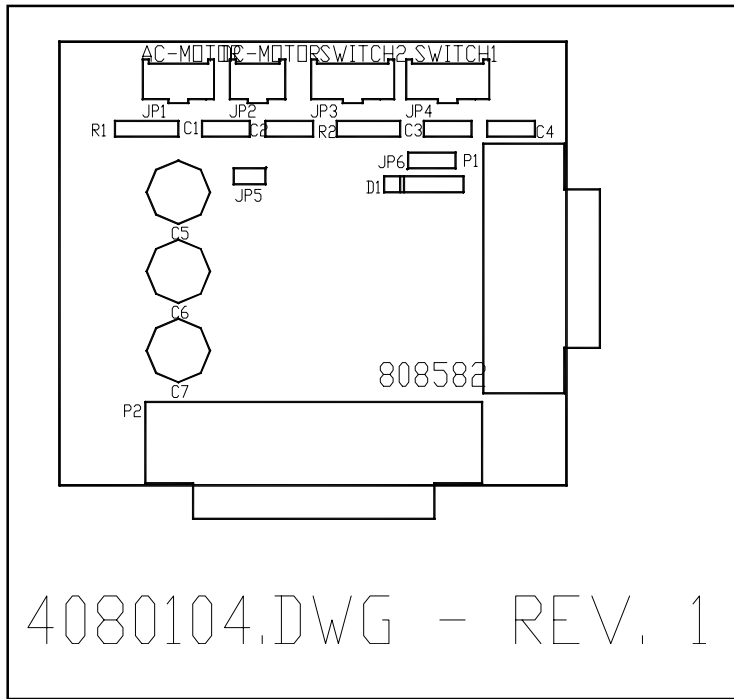

SECTION 8

Interconnection Modul, Drawing 464609

# SECTION EIGHT: On-Line Description Heidelberg Models *Combi*

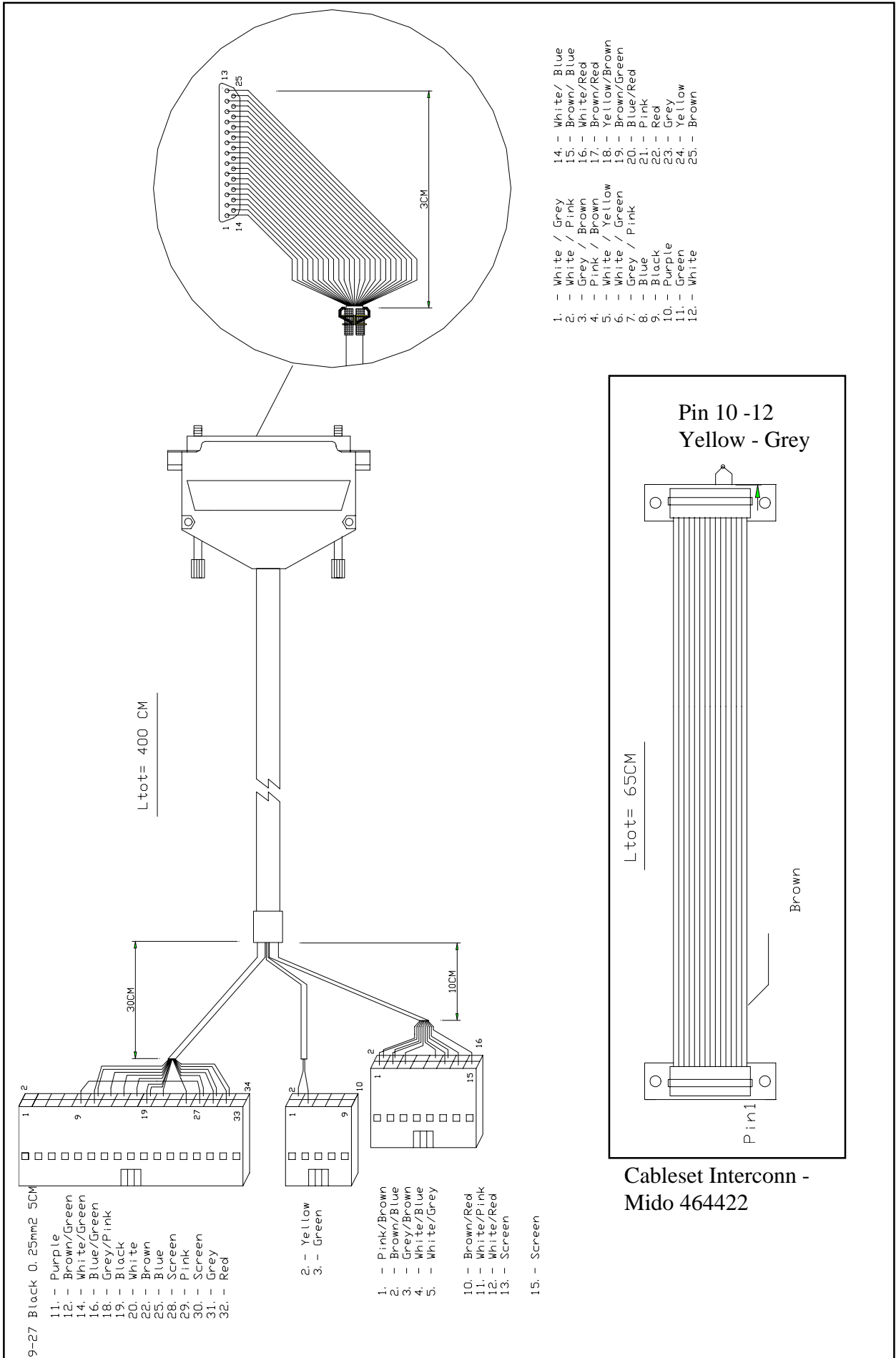

Cableset Conveyor C-box, Drawing 464424

**SECTION EIGHT: On-Line Description Heidelberg Models *Combi***

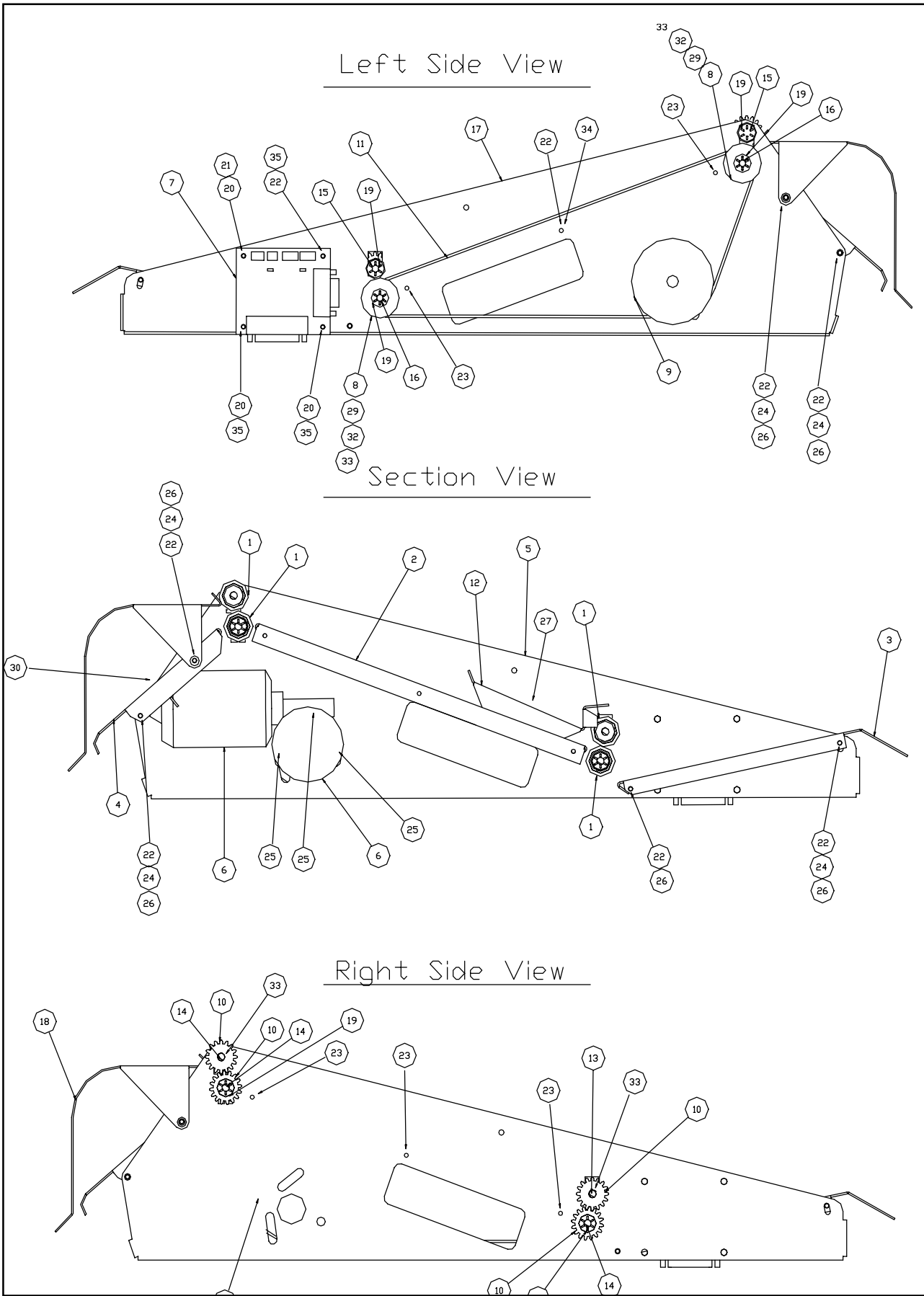

**SECTION 8**

## SECTION EIGHT: On-Line Description Heidelberg Models *Combi*

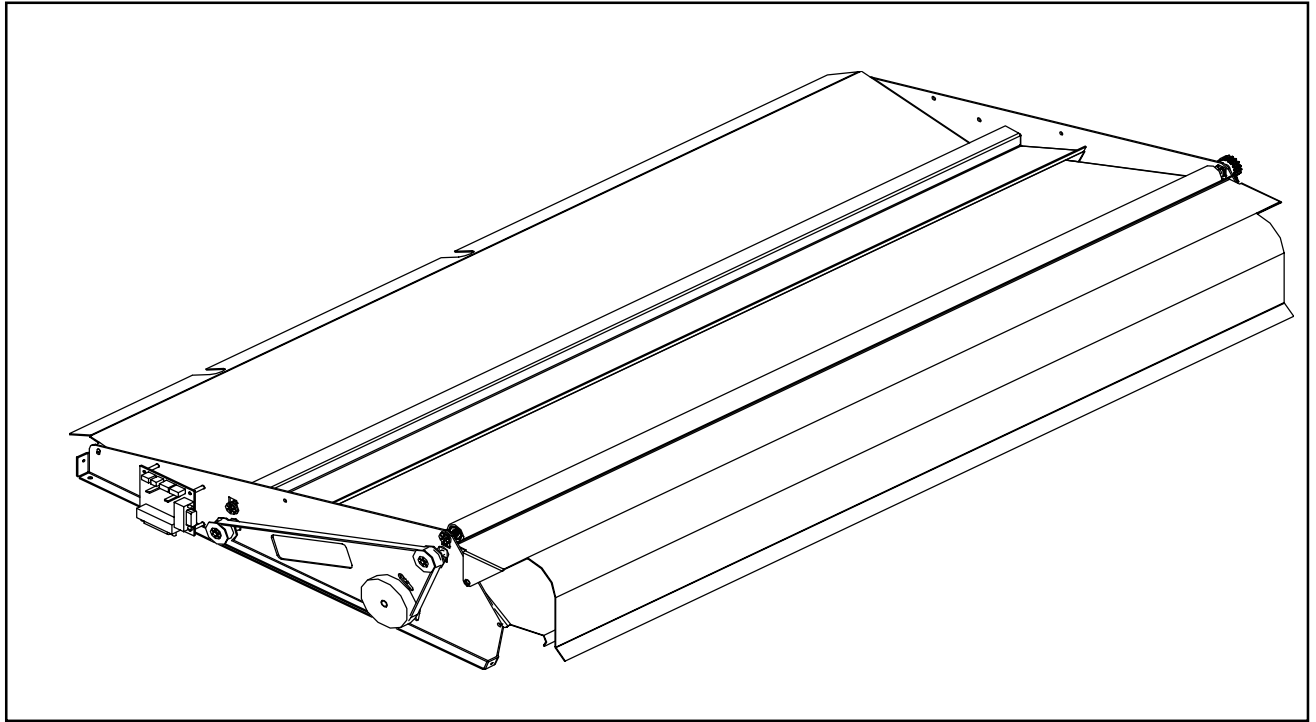

Styklist						
Pos.	Tegn.nr.: Primesetter 102	Tegn.nr.: Primesetter 74	Seq.nr	Navn Primesetter 102	Navn Primesetter 74	Stk
1	330354	136354	10-040	Roller soft EPDM 1' x 1143	Roller soft EPDM 1'x36'	4
2	464582	464082	10-070	Midlow guide Primesetter 102	Midlow guide Primesetter 74	1
3	464581	464081	10-065	Outlet guide Primesetter 102	Outlet guide Primesetter 74	1
4	464585	464085	10-085	Low inletguide Primesetter 102	Low inletguide primesetter 74	1
5	464471		10-000	Rackside Primesetter 74/102		1
6	70161		10-115	DC motor Bo. 42RPM 600Ncm 24V		1
7	464609		10-609	Intercon module w. plugs prime		1
8	317514		10-035	Timing Pulley 16T		2
9	129335		10-020	Timing Belt Pulley 44xL037 key		1
10	65270		10-100	Gearwheel 16T 1/4 In D		4
11	464476		10-060	Timing Belt 320xL037		1
12	464583	464083	10-075	Midupper guide Primesetter 102	Midupper guide Primesetter 74	1
13	217184		10-025	1/4"x12x12 BEARING		8
14	235234		10-030	Axle-D 1/4 IN,Long F.I.G.W		4
15	65386		10-110	Axle-ø 1/4"x29,3		2
16	448554		10-050	Ø axle 01/4" x 06 x 56		2
17	464491		10-005	Rackside L Primesetter 74/102		1
18	464584	464084	10-080	Top inletguide primesetter 102	Top inletguide Primesetter 74	1
19	117337		10-015	Starlock 1/42" stainless		6
20	88001		10-165	Screw MG 3x6 A4 Din 84		6
21	888002		10-160	Lock Disc 3,2 MM A4 Din 6798		1
22	88201		10-155	Spring Washer 4mm A4 Din 127B		11
23	88392		10-150	Pop Rivet Type SS/D/43SS		6
24	88212		10-145	Flatwasher 4.3x9x08MM A4 125A		6
25	88104		10-135	Screw Set MG 6x10 A4 Din 933		3
26	88102		10-130	Screw Set Mg 4x10 A4 Din 933		8
27	7094		10-125	Sensor Arrow		1
28	7061		10-120	Modification Label		1
29	65274		10-105	Pulleys 1/4in Ø		4
30	6096		10-095	Microsw. Reed ang. 59200-020		1
31	464400		10-055	Cableset conv.primeset.74/102		1
32	448507		10-045	Bearing clutch one way Ø10x06		2
33	117336		10-010	Starlock 05 stainless		2
34	88021		10-170	Screw PHRX 4x6 A4 Din 7985		1
35	88200		10-175	Spring Washer 3MM A4 Din 127B		3



**SECTION EIGHT: On-Line Description Heidelberg Models *Combi***

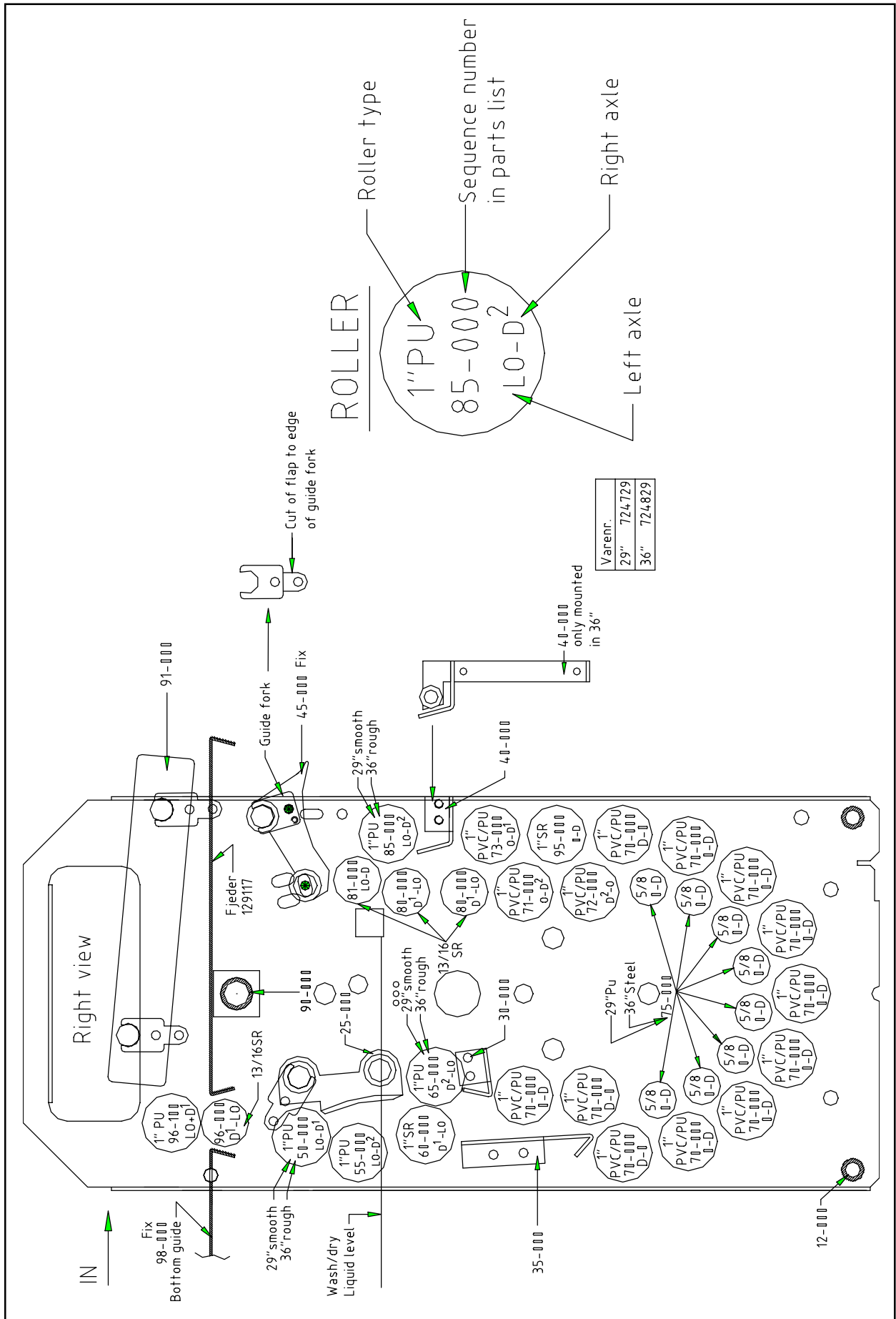

Fix1 Rack 36" R44 Combi, Drawing 324729

**SECTION 8**



# SECTION EIGHT: On-Line Description Heidelberg Models *Combi*

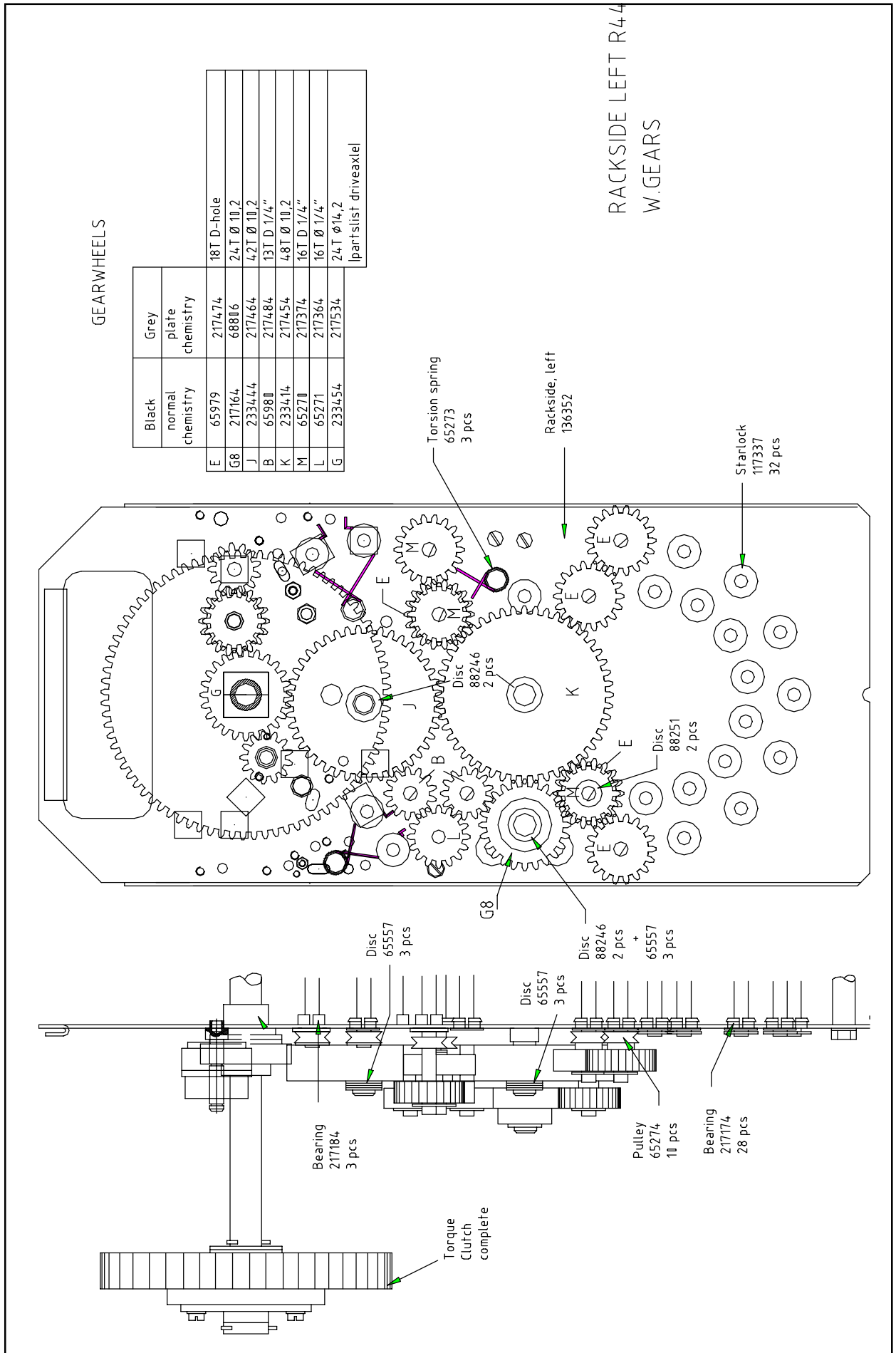

Rack Side l.w.Gears Dev./Fix. R44 Combi, Drawing 5788

## SECTION 8

# SECTION EIGHT: On-Line Description Heidelberg Models *Combi*

## SECTION 8

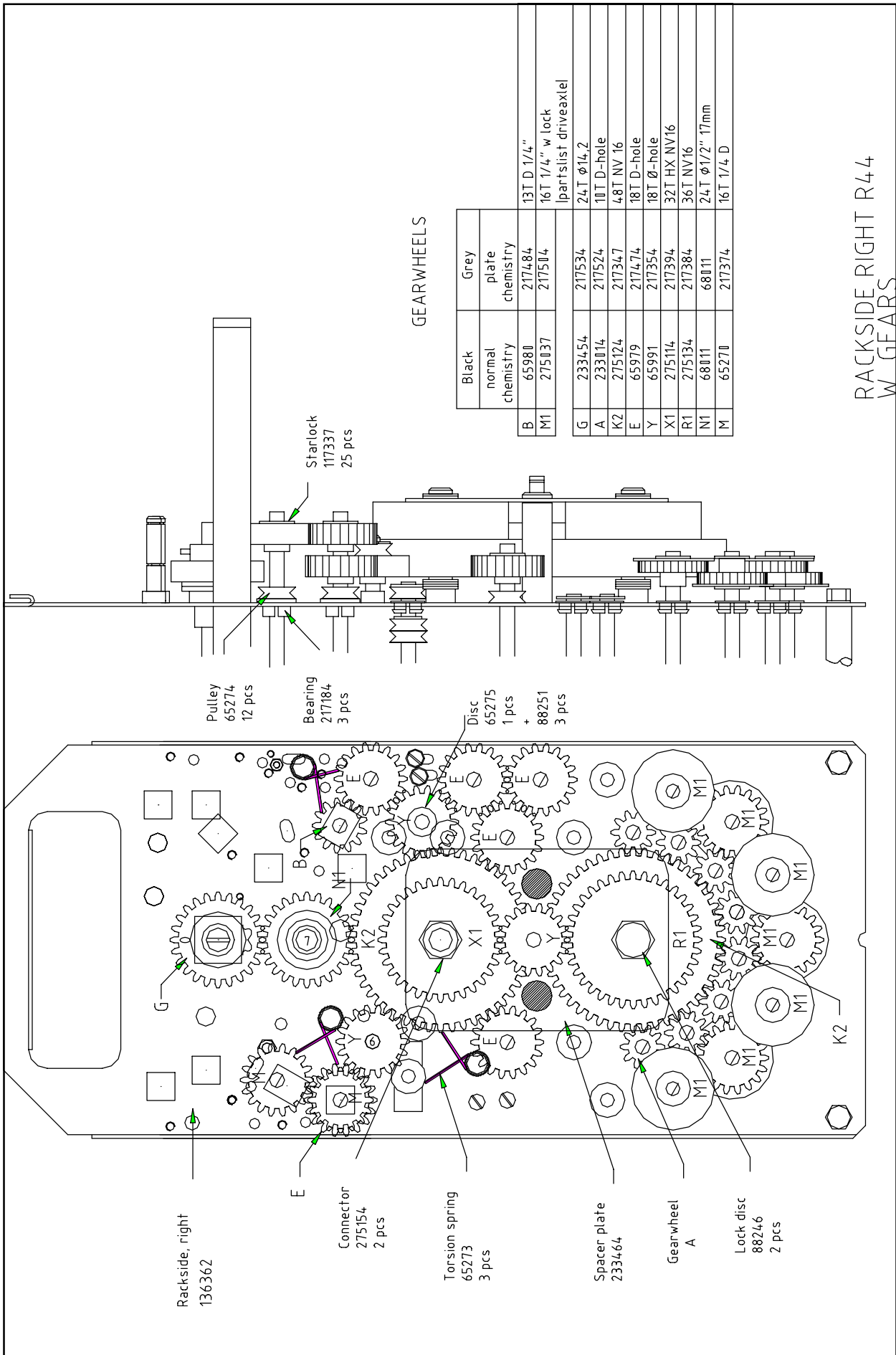

Rack Side r.w.Gears Dev./Fix. R44 Combi, Drawing 5792

# SECTION EIGHT: On-Line Description Heidelberg Models *Combi*

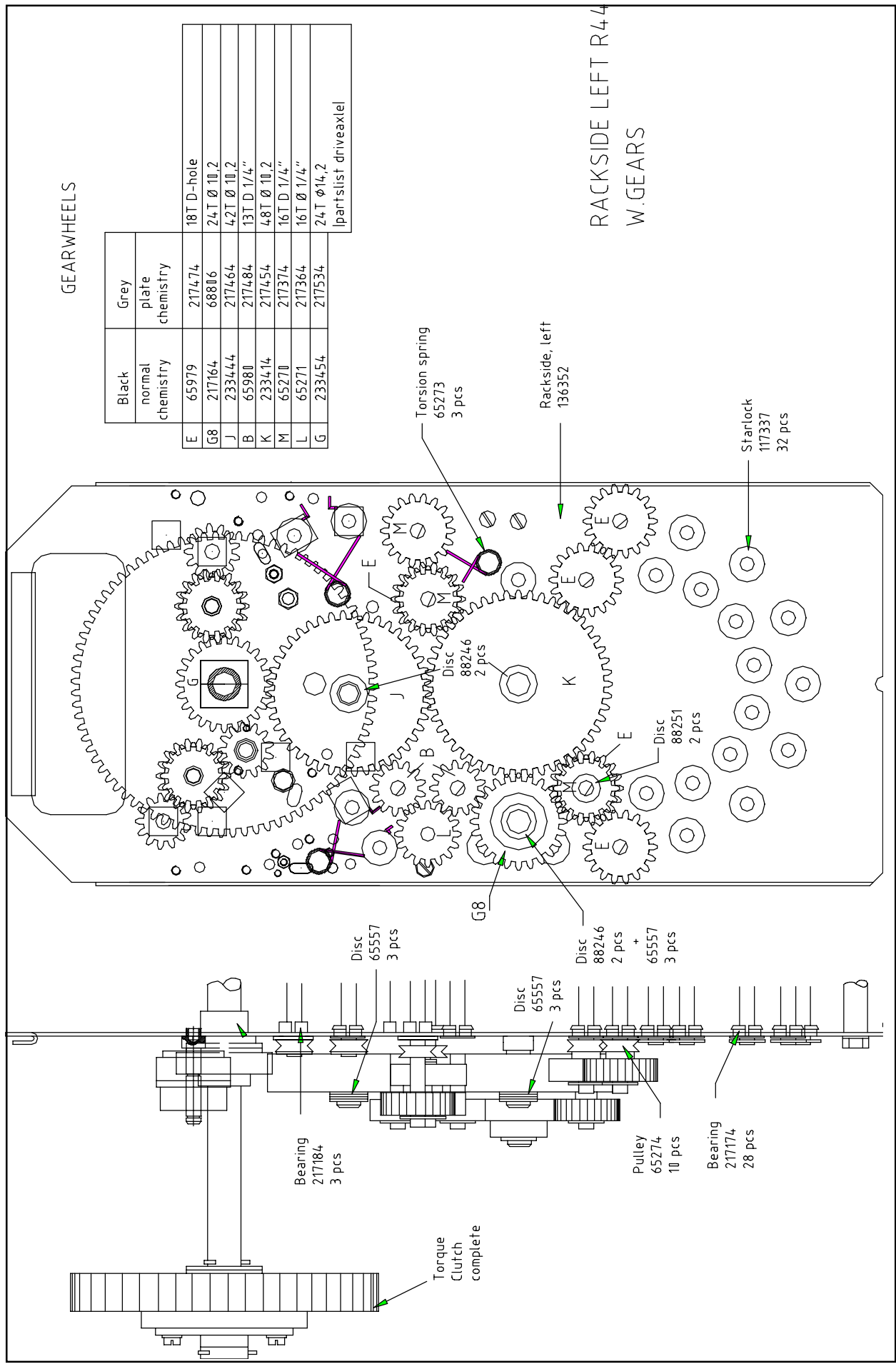

Rackside l.w.Gears Wash R44 Combi, Drawing 5789

**SECTION 8**

# SECTION EIGHT: On-Line Description Heidelberg Models *Combi*

## SECTION 8

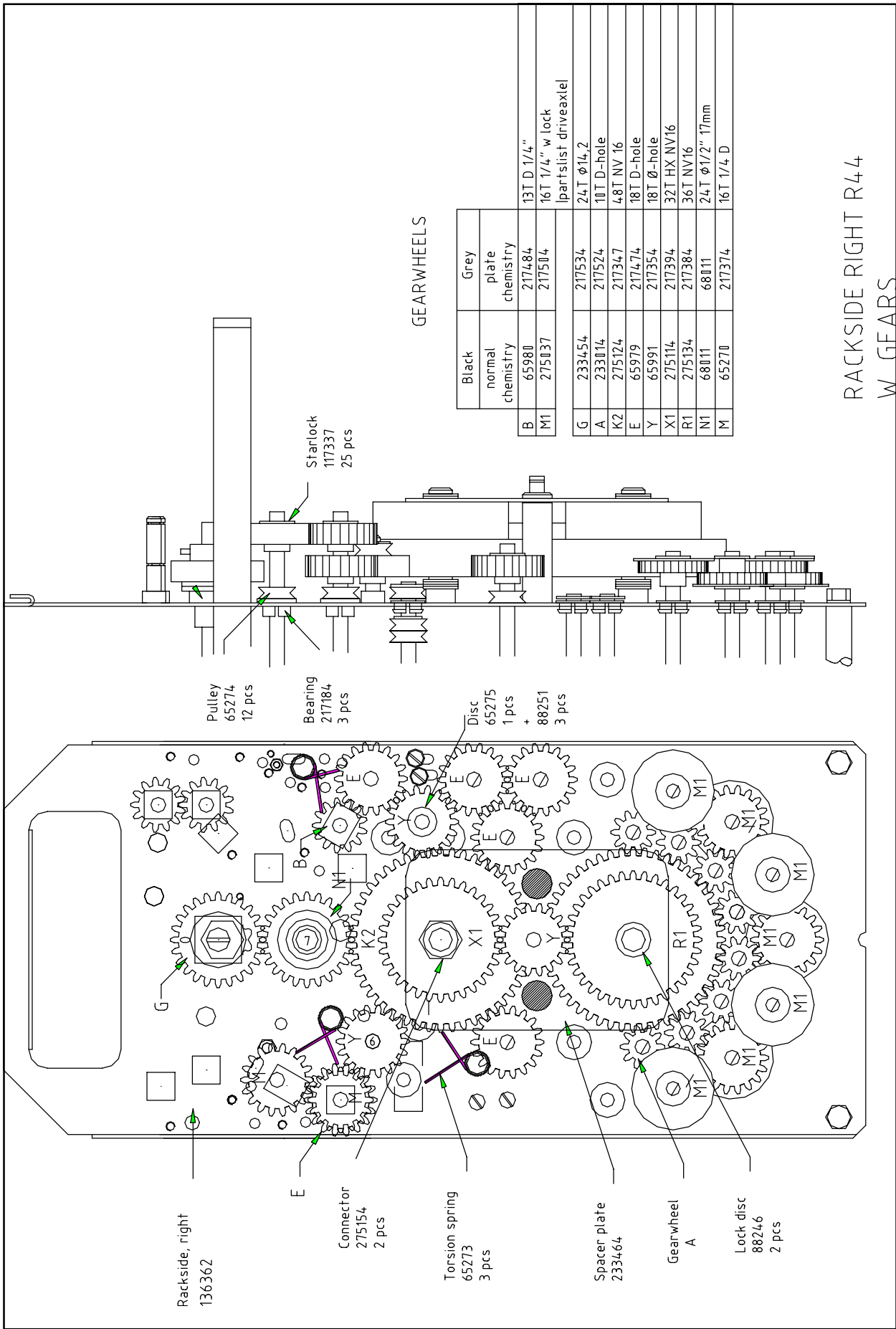

Rack Side r.w.Gears Wash R44 Combi, Drawing 5793

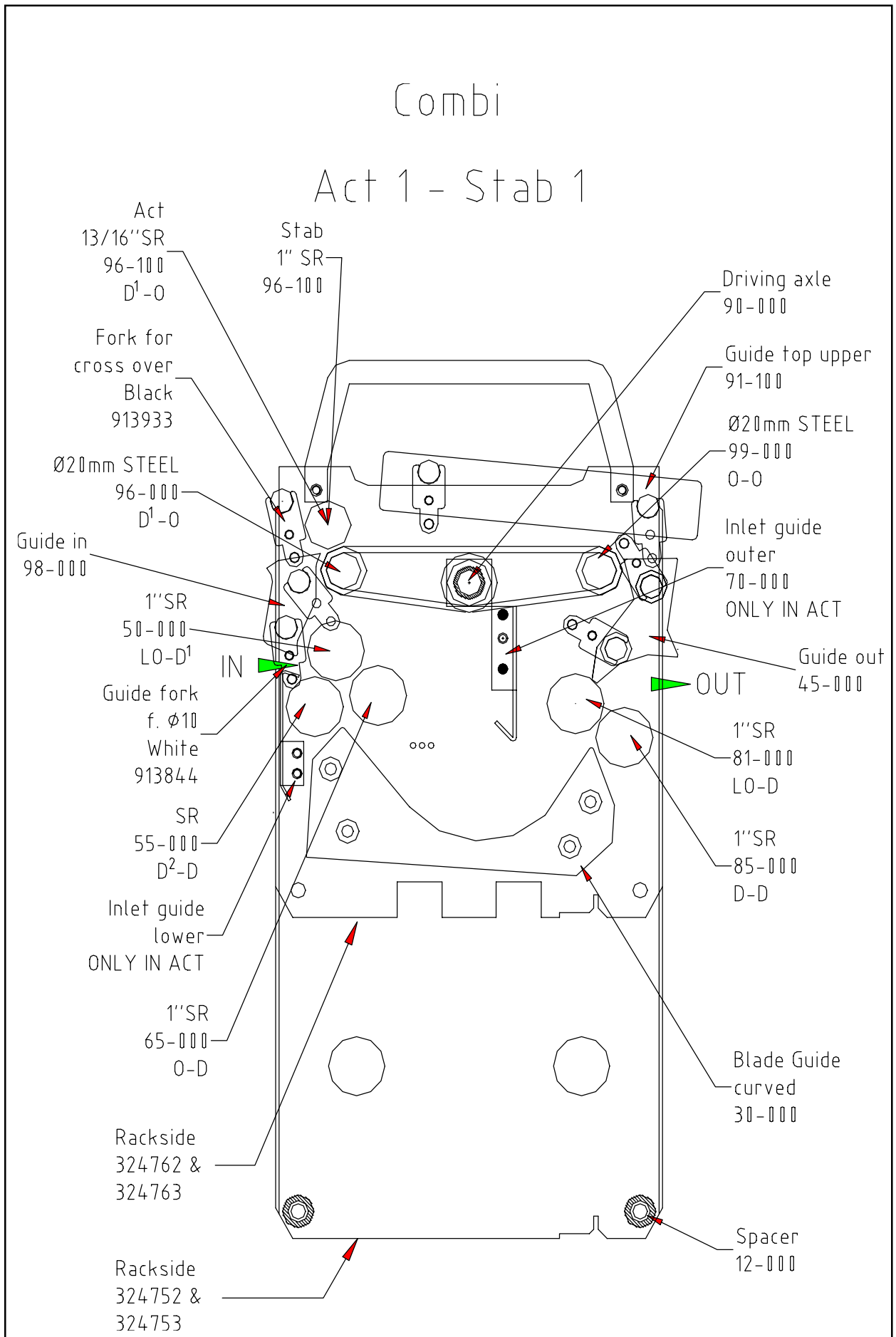

Fix. Rack/Act. Rack 36"R20 Combi E\C\sh, Drawing 5975a

Combi

Wash 2

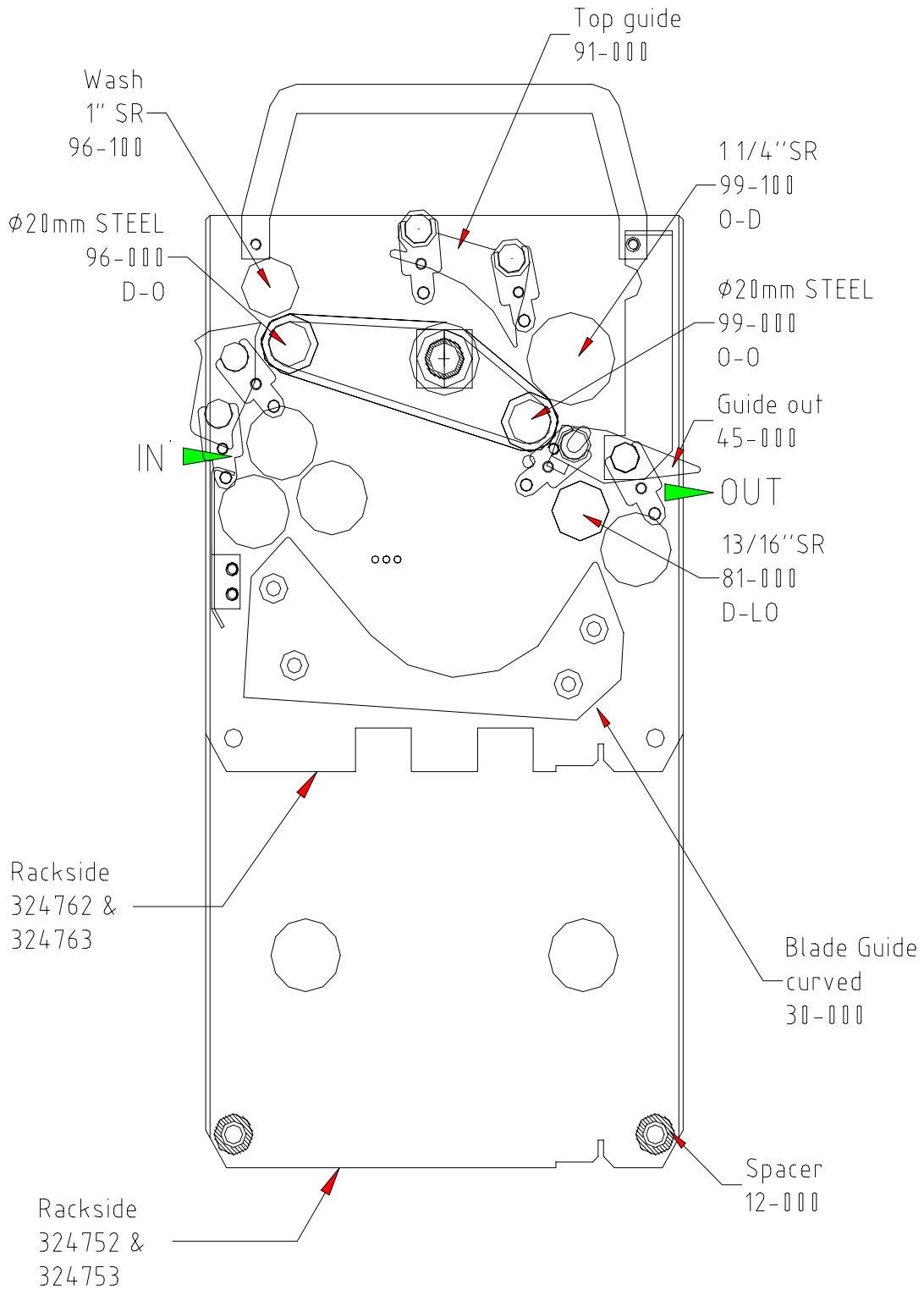

Wash2 Rack 36"R20 Combi E/C/sh, Drawing 5975b

**SECTION EIGHT: On-Line Description Heidelberg Models *Combi***

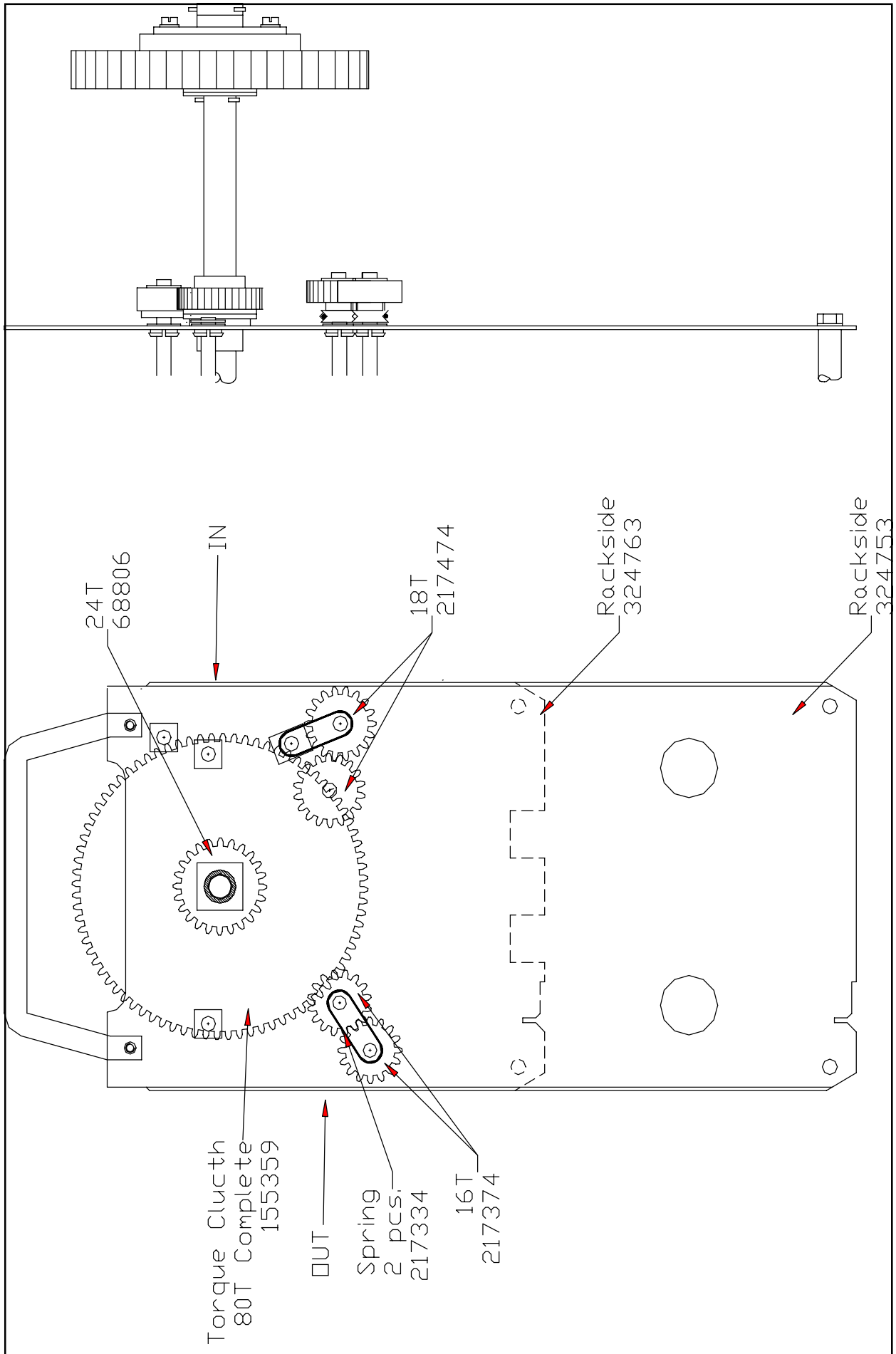

Rack Side l.w.Gears R20, Drawing 324815

**SECTION 8**

**SECTION EIGHT: On-Line Description Heidelberg Models *Combi***

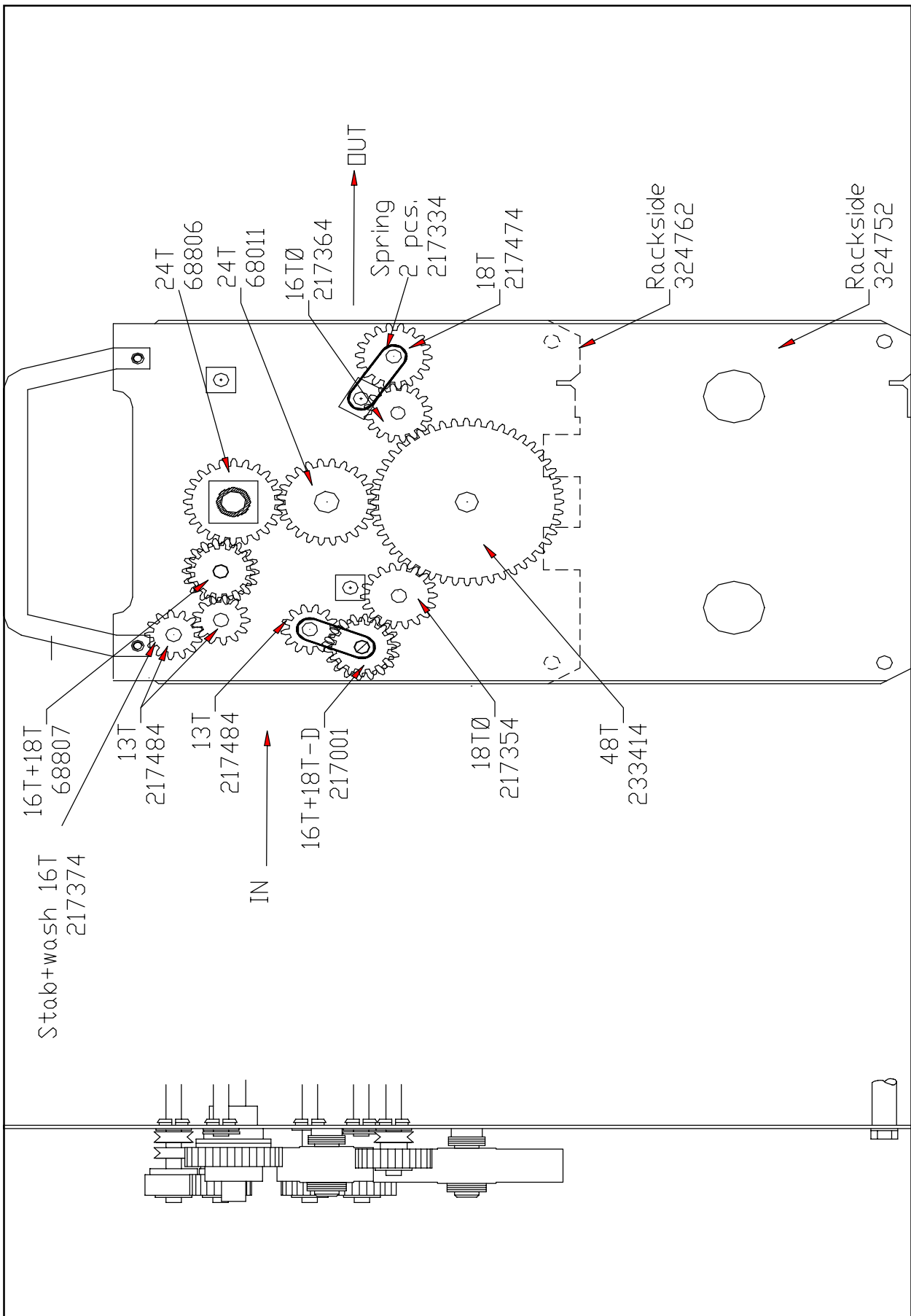

**SECTION 8**

Rack Side r.w.Gears R20, Drawing 324825





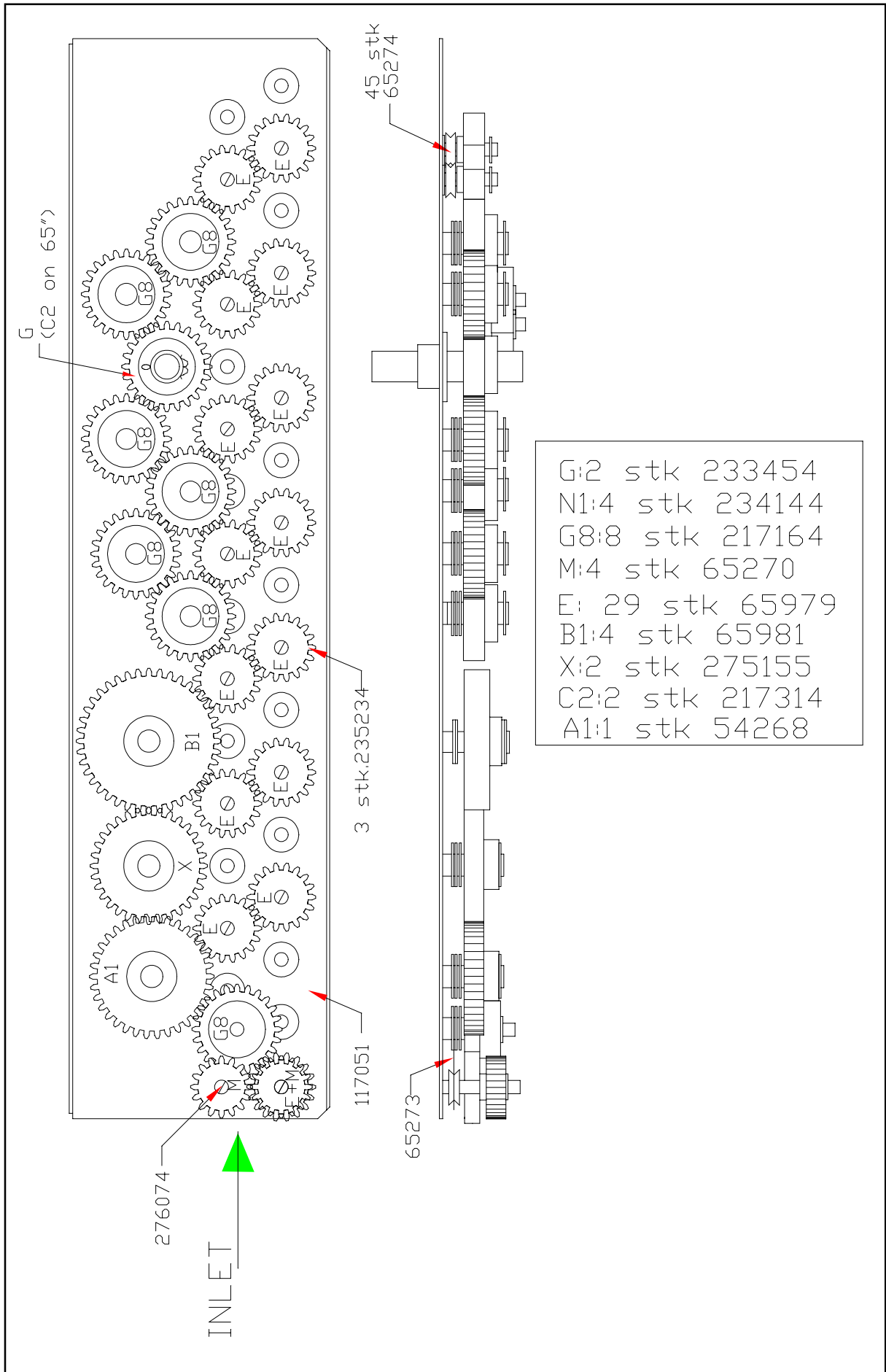

R33 Horizontal Dryer Gearwheel Position Right Side, Drawing 5930

Empty page

# SECTION EIGHT: On-Line Description Heidelberg Models *Combi*

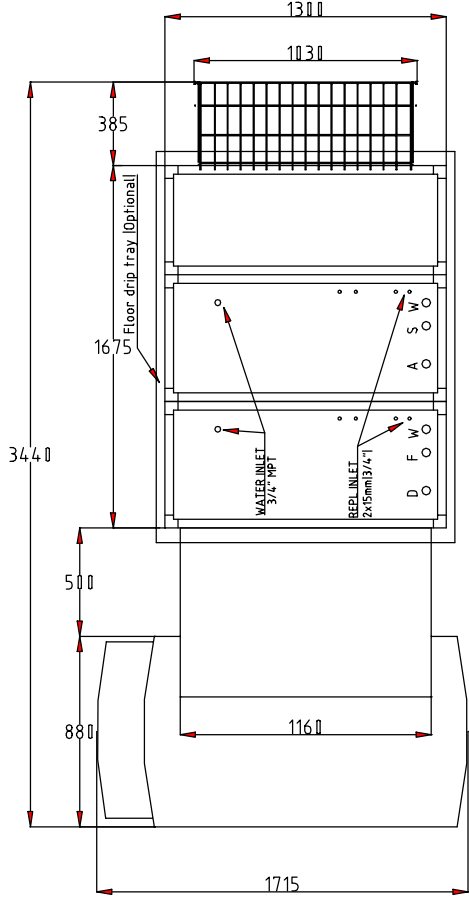
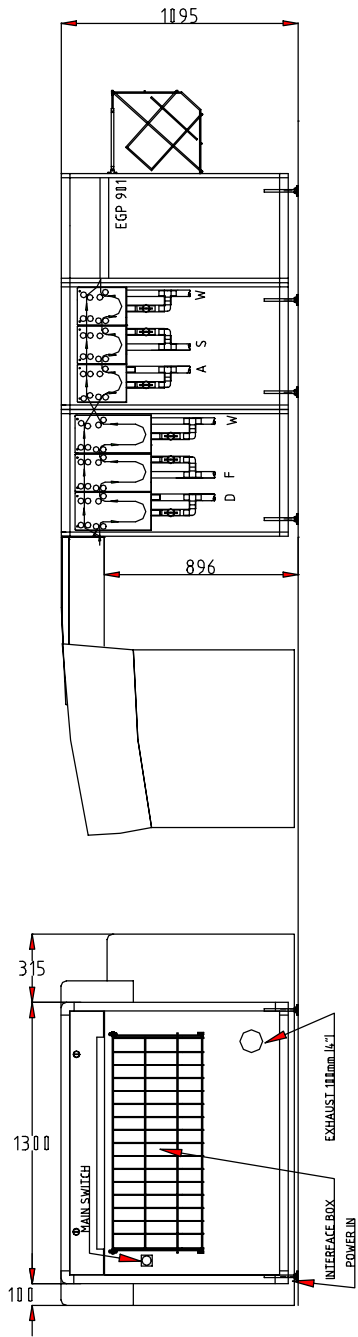

- Supply  
Alimentation  
Strom Versorgung
- 2 ~ N PE AC 400V or ou oder
  - 3 ~ PE AC 230V or ou oder
  - 2 ~ PE AC 230V or ou oder
  - 2 ~ PE AC 230V
- Fuse  
Fusible  
Empfohlener schutz
- at 2 ~ 127V
  - bei 1 ~ 220V
- 16A (32A & )
- 
- 30 L
- 2 pcs. repl. containers

<b>Echo Graphic A/S</b>		Design/Draw : CK/CK	Scale : 1 : 30	Date : 11 -01 -00
Haandvaerkervej 2 DK-9560 Hadsund, Denmark		Installation view EGP 901		
Phone int.: +45 98 57 19 55		Name : PRIMESETTER 74		
Fax int.: +45 98 57 15 91		Drawing no. : 6316		

Installationview 6316

# SECTION EIGHT: On-Line Description Heidelberg Models *Combi*

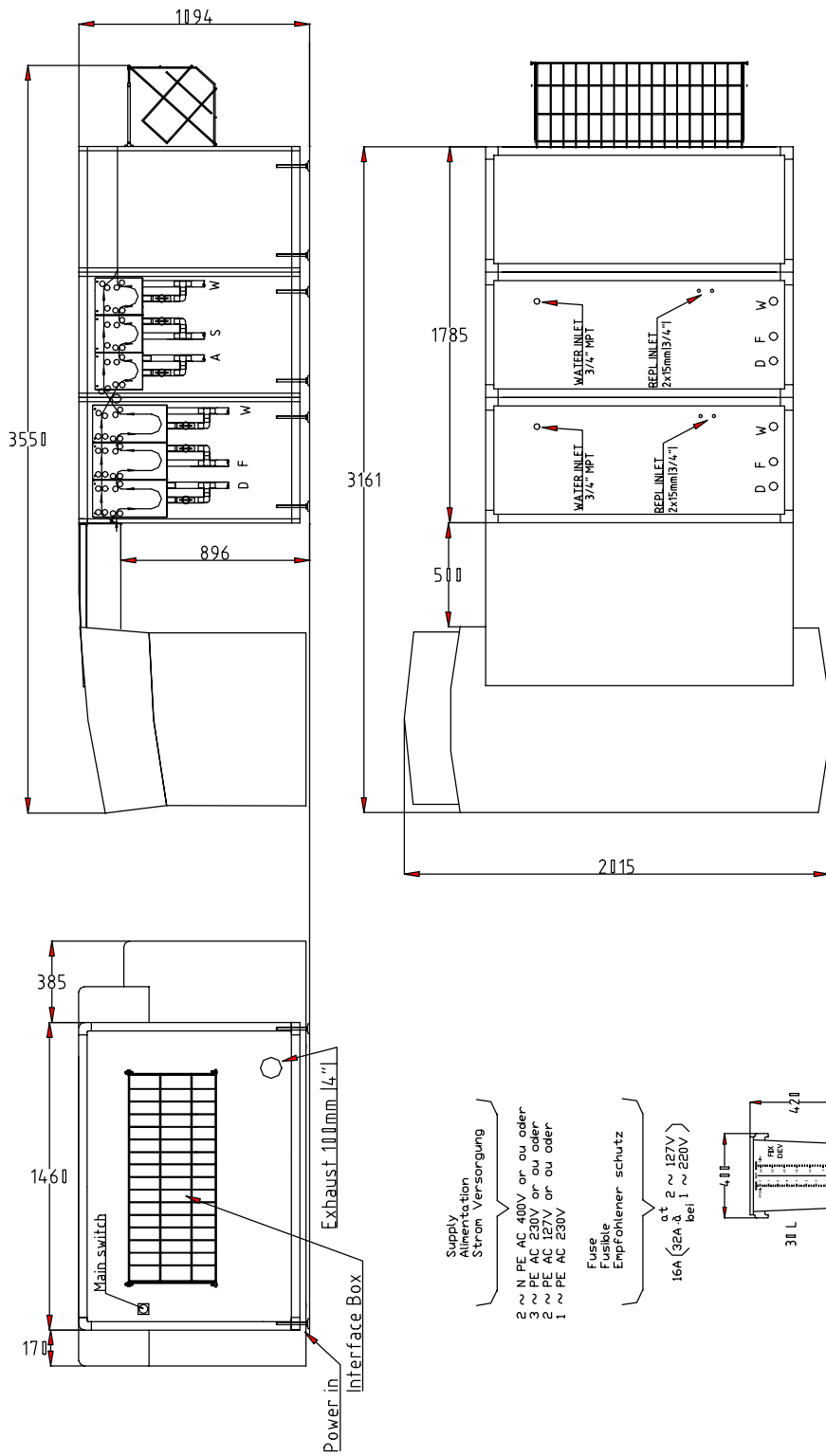

<b>Echo Graphic A/S</b> Haandvaerkervej 2 DK-9560 Hadsund, Denmark Phone int.: +45 98 57 19 55 Fax int.: +45 98 57 15 91		Design/Draw : UN/UN	Scale : 1 : 30	Date : 28 - 02 - 00
		Installation view EGP 1141		
		Drawing no. : 6323		
		Name : PRIMESETTER 102		

## SECTION 8

Installationview 6323

**Hope / Carnfeldt On-Line Processor for Heidelberg Primesetter 74**

	<b>EG 901, film</b>	<b>EG 900, film</b>	<b>EP 900, poly</b>	<b>EGP 901, combi</b>
<b>Dimensions of on-line system</b>				
Length	296 cm / 116.5"	274 cm / 107.9"	275 cm / 108.3"	355 cm / 139.8"
Width	172 cm / 67.7"	172 cm / 67.7"	172 cm / 67.7"	172 cm / 67.7"
Height	110 cm / 43.3"	110 cm / 43.3"	110 cm / 43.3"	110 cm / 43.3"
<b>Shipping dimensions</b>				
Length	175 cm / 68.9"	175 cm / 68.9"	175 cm / 68.9"	228 cm / 89.8"
Width	142 cm / 55.9"	142 cm / 55.9"	142 cm / 55.9"	142 cm / 55.9"
Height	129 cm / 50.8"	129 cm / 50.8"	129 cm / 50.8"	137 cm / 53.9"
<b>Weight</b>				
Net	365 kg / 805 lb.	300 kg / 661 lb.	250 kg / 551 lb.	585 kg / 1290 lb.
Gross	460 kg / 1014 lb	380 kg / 838 lb.	340 kg / 750 lb.	680 kg / 1500 lb.
<b>Specifications</b>				
Inlet width	91 cm / 36"	91 cm / 36"	91 cm / 36"	91 cm / 36"
Tank capacity	29 l/7.7 US gal.	29 l/7.7 US gal.	16 l/4.3 US gal.	29/16 l/7.7/4.3 US gal
Rack length dev.	44 cm / 17.3"	32 cm / 12.6"	20 cm 7.9"	44/20 cm/17.3/12.6"
Developing time min.-max.	15 – 90 sec.	20 – 80 sec.	15 – 90 sec.	15 – 90 sec.
Speed at 30 sec. dev. time	88 cm/min. 34.6"/min	64 cm/min. 25.2"/min	-	88 cm/min. 34.6"/min
Speed at 20 sec. dev. time	-	-	60 cm/min. 23.6"/min	60 cm/min.
Max. film length off-line	10 m / 32.8 ft	10 m / 32.8 ft	2 m / 6.6 ft	-
Min. film size off-line	30 x 42 cm 11.8 x 16.5"	30 x 42 cm 11.8 x 16.5"	30 x 42 cm 11.8 x 16.5"	30 x 42 cm 11.8 x 16.5"
Max. format (set by imagesetter)	76 x 86 cm 29.9 x 33.9"	76 x 86 cm 29.9 x 33.9"	76 x 86 cm 29.9 x 33.9"	76 x 86 cm 29.9 x 33.9"
Dev./fix./wash temperature range	20 - 45°C 68 - 113°F	20 - 45°C 68 - 113°F	20 - 45°C 68 - 113°F	20 - 45°C 68 - 113°F
Exhaust blower	Built in	Built in	Built in	Built in
Exhaust connection	Ø 10 cm	Ø 10 cm	Ø 10 cm	Ø 10 cm
Circulation rate dev., fix.	22 l/min. 5.8 US gal	10 l/min. 2.7 US gal	10 l/min. 2.7 US gal	22 l/min/10 l/min. 5.8 /2.7 US gal
Water consumption (operate)	3.5 l/min. 0.9 US gal	3.5 l/min. 0.9 US gal	3.5 l/min. 0.9 US gal	3.5 l/min. 0.9 US gal
Emission of heat to room (operate)	3000 W	3000 W	3000 W	3000 W
Water connection	¾" pipe thread	¾" pipe thread	¾" pipe thread	¾" pipe thread
Drain connection	3x1" hose nipple	3x1" hose nipple	3x1" hose nipple	6x1" hose nipple
Repl. containers (dev. and fix.)	30 l/ 8 US gal.	30 l/ 8 US gal.	30 l/8 US gal.	4 x 30 l/ 8 US gal.
Max. power consumption	5900 VA	5900 VA	5900 VA	7600 VA
Average power consumption:				
Operate	5000 W	5000 W	5000 W	6200 W
Power save	1000 W	1000 W	1000 W	1000 W
Night mode	600 W	600 W	600 W	1100 W
Power supply:				
1x230ACV+/-10% / 50/60Hz	30 amp	30 amp	30 amp	40 amp
3x230ACV+/-10% / 50/60Hz	3 x 16 amp	3 x 16 amp	3 x 16 amp	3 x 16 amp

**Hope / Carnfeldt On-Line Processor for Heidelberg Primesetter 102**

	<b>EG 1141, film</b>	<b>EP 1140, poly</b>	<b>EGP 1141, combi</b>
<b>Dimensions of on-line system</b>			
Length	296 cm / 116.5"	275 cm / 108.3"	355 cm / 139.8"
Width	202 cm / 79.5"	202 cm / 79.5"	202 cm / 79.5"
Height	110 cm / 43.3"	110 cm / 43.3"	110 cm / 43.3"
<b>Shipping dimensions</b>			
Length	175 cm / 68.9"	175 cm / 68.9"	191 cm / 75.2"
Width	158 cm / 62.2"	142 cm / 55.9"	185 cm / 72.8"
Height	129 cm / 50.8"	129 cm / 50.8"	132 cm / 52.0"
<b>Weight</b>			
Net	400 kg / 882 lb.	370 kg / 816 lb.	650 kg / 1433 lb.
Gross	560 kg / 1235 lb.	470 kg / 1036 lb.	770 kg / 1698 lb.
<b>Specifications</b>			
Inlet width	114 cm / 45"	114 cm / 45"	114 cm / 45"
Tank capacity	36 l / 9.5 US gal.	18 l / 7.1 US gal.	36/18 l 9.5/7.1 US gal
Rack length dev.	44 cm / 17.3"	20 cm / 7.9"	44/20 cm / 17.3/7.9"
Developing time min.-max.	15 – 90 sec.	15 – 90 sec.	15 – 90 sec.
Speed at 30 sec. dev. time	88 cm/min./34.6"/min.	-	88 cm/min./34.6"/min
Speed at 20 sec. dev. time	-	60 cm/min./ 23.6"/min.	60 cm/min./23.6"/min
Max. film length off-line	10 m / 32.8 ft	2 m / 32.8 ft	2 m / 32.8 ft
Min. film size off-line	30x42 cm / 11.8x16.5"	30x42 cm / 11.8x16.5"	30x42cm 11.8x16.5"
Max. format (set by imagesetter)	108x86 cm / 42.5x33.9"	108x86 cm / 42.5x33.9"	108x86 cm 42.5x33.9"
Dev./fix./wash temperature range	20-45°C/68-113°F	20-45°C/68-113°F	20-45°C/68-113°F
Exhaust blower	Built in	Built in	Built in
Exhaust connection	Ø 10 cm	Ø 10 cm	Ø 10 cm
Circulation rate dev., fix.	22 l/min. / 5.8 US gal	10 l/min./2.7 US gal	22/10 l/min. 5.8/2.7 US gal
Water consumption (operate)	3.5 l/min. / 0.9 US gal.	3.5 l/min. / 0.9 US gal.	3.5 l/min. /0.9 US gal
Emission of heat to room (operate)	3000 W / 879 BTU/hr.	3000 W / 879 BTU/hr.	3000 W/879 BTU/hr.
Water connection	¾" pipe thread	¾" pipe thread	¾" pipe thread
Drain connection	3 x 1" hose nipple	3 x 1" hose nipple	6 x 1" hose nipple
Replenishment containers	Dev./fix. 30 l / 8 US gal.	Dev./fix. 30 l / 8 US gal.	4x30 l. / 4x8 US gal.
Max. power consumption	5900 VA	5900 VA	7600 VA
Average power consumption:			
Operate	5000 W	5000 W	6200 W
Power save	1000 W	1000 W	1000 W
Night mode	600 W	600 W	1100 W
Power supply:			
1x230ACV+/-10% / 50/60Hz	40 amp	40 amp	40 amp
3x230ACV+/-10% / 50/60Hz	3 x 16 amp	3 x 16 amp	3 x 16 amp